

Optical Clock Module

(CRAY T90™ Series)

HTM-077-A

Cray Research/Silicon Graphics Proprietary

Cray Research, Inc.

Record of Revision

REVISION	DESCRIPTION
----------	-------------

March 1995. Original printing.

April 1997. Modified Figure 3 and made other minor changes.

Any shipment to a country outside of the United States requires a letter of assurance from Cray Research, Inc.
--

This document is the property of Cray Research, Inc. The use of this document is subject to specific license rights extended by Cray Research, Inc. to the owner or lessee of a Cray Research, Inc. computer system or other licensed party according to the terms and conditions of the license and for no other purpose.

Cray Research, Inc. Unpublished Proprietary Information — All Rights Reserved.

Autotasking, CF77, CRAY, CRAY-1, Cray Ada, CraySoft, CRAY Y-MP, CRInform, CRI/TurboKiva, HSX, LibSci, MPP Apprentice, SSD, SUPERCLUSTER, SUPERSERVER, UNICOS, and X-MPE EA are federally registered trademarks and Because no workstation is an island, CCI, CCMT, CF90, CFT, CFT2, CFT77, ConCurrent Maintenance Tools, COS, CRAY-2, Cray Animation Theater, CRAY APP, CRAY C90, CRAY C90D, Cray C++ Compiling System, CrayDoc, CRAY EL, CRAY J90, CRAY J90se, Cray NQS, Cray/REELlibrarian, CRAY S-MP, CRAY SSD-T90, CRAY T3D, CRAY T3E, CRAY T3E-900, CRAY T90, CrayTutor, CRAY X-MP, CRAY XMS, CS6400, CSIM, CVT, Delivering the power . . ., DGauss, Docview, EMDS, GigaRing, HEXAR, IOS, ND Series Network Disk Array, Network Queuing Environment, Network Queuing Tools, OLNET, RQS, SEGLDR, SMARTE, SUPERLINK, System Maintenance and Remote Testing Environment, Trusted UNICOS, UNICOS MAX, and UNICOS/mk are trademarks of Cray Research, Inc.

Silicon Graphics and the Silicon Graphics logo are registered trademarks and Origin and Origin2000 are trademarks of Silicon Graphics, Inc.

Requests for copies of Cray Research, Inc. service publications should be directed to:

CRAY RESEARCH, INC.
Customer Service Logistics
1100 Lowater Road
P.O. Box 4000
Chippewa Falls, WI 54729-0078
USA

Comments about this publication should be directed to:

CRAY RESEARCH, INC.
Service Publications and Training
890 Industrial Blvd.
P.O. Box 4000
Chippewa Falls, WI 54729-0078
USA

OPTICAL CLOCK MODULE

Optical Clock Module Overview	3
Module Components	4
Oscillators	4
Integrated Circuits (ICs)	5
Optical Transmitter Module (OTM)	5
Coupler	6
Connectors	6
CRAY T94 Clock Deck	7
Optical Clock Path	8
Clock Distribution on System Modules	10
Laser Safety: CRAY T90 Series Systems as Laser Products	11

Figures

Figure 1. Optical Clock Signal Path	3
Figure 2. Optical Clock Module	4
Figure 3. CRAY T94 Clock Deck	7
Figure 4. Optical Clock Path	8
Figure 5. Optical Clock Module Block Diagram	9
Figure 6. System Module Clock Distribution Block Diagram	10
Figure 7. Sample Caution Label for a Class I Laser Product ..	12

Tables

Table 1. CRAY T90 Series OTM Specifications	5
Table 2. Right-angle Head Connectors	6
Table 3. Laser Classes	11

This page intentionally left blank.

Optical Clock Module Overview

The optical clock module generates an optical clock signal and sends it to all system modules. Each CRAY T90 series system has one optical clock module. In CRAY T94 systems, the optical clock module is mounted on a clock deck and is located on the top of the card cage. In CRAY T916 and CRAY T932 systems, the optical clock module is located between memory module stack D and memory module stack H and is labeled Clock Box. The optical clock module has its own power supply. Refer to the appropriate CRAY T90 Series Power, Cooling and Control System document for more information on the clock module power supply.

The optical clock module consists of two 4 in. × 9 in. printed circuit boards: an oscillator board and a laser board. The oscillator board contains the oscillators and integrated circuits. The laser board contains the optical transmitter modules (OTMs), which house the lasers. Two types of laser boards are available: LP01 for CRAY T94 systems and HP01 for CRAY T916 and CRAY T932 systems.

Figure 1 shows the path of the optical clock signal. The oscillators generate an electrical clock signal and send it to the OTMs, which convert it to an optical signal and then send it through the fiber-optic waveguides to an optical receiver on each system module. The optical receiver converts the signal back to an electrical signal and distributes it to a TZ option, which, in turn, distributes it to each option on the system module.

Figure 1. Optical Clock Signal Path

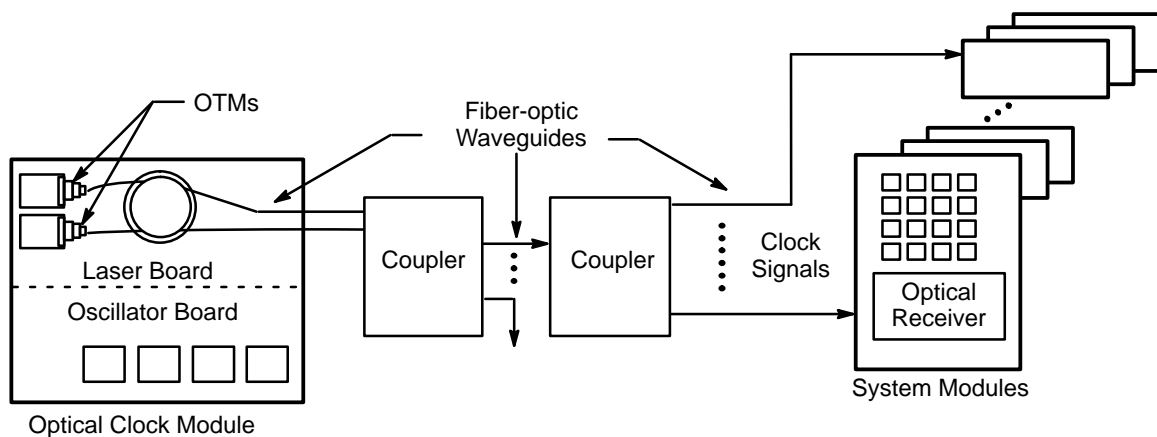

Module Components

An optical clock module consists of a laser board and an oscillator board. The laser board contains the OTMs and connectors. The oscillator board contains the oscillators, integrated circuits (ICs), and connectors. Figure 2 illustrates the components on an optical clock module.

Figure 2. Optical Clock Module

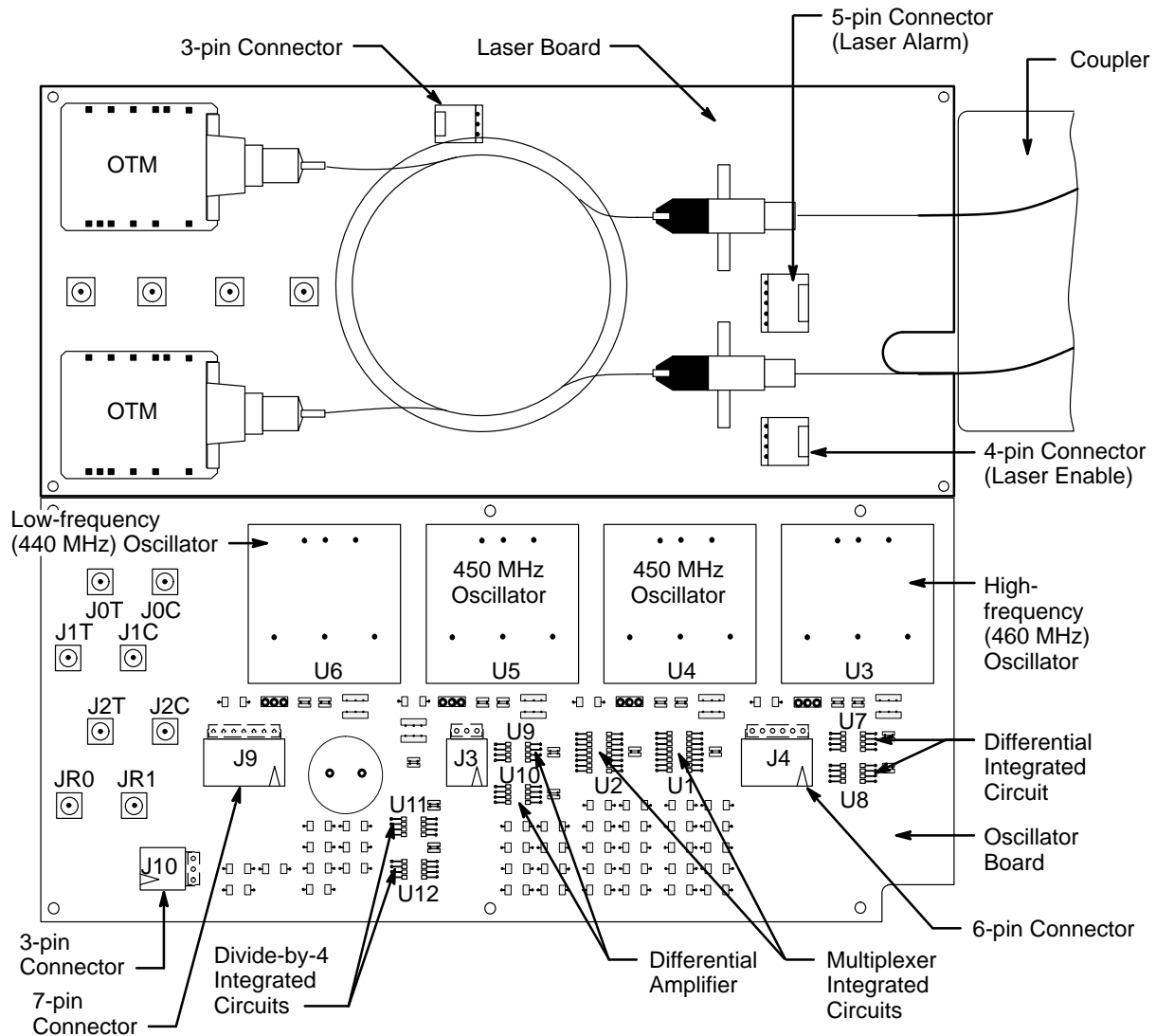

Oscillators

The oscillators create a differential electronic clock (ECL level) signal to drive the OTMs. Four oscillators on the module allow for three different clock frequency levels: the U4 and U5 oscillators provide a 450-MHz

clock signal, the high-frequency oscillator provides a 460-MHz frequency signal, and the low-frequency oscillator provides a 440-MHz frequency signal. Oscillators U4 and U5 are the normal clock frequency oscillators, which provide the CRAY T90 series systems with a 2.2-ns clock. Two normal frequency oscillators are available for redundancy purposes; if one oscillator fails, the second oscillator generates the clock signal. The second oscillator is selected by the control system. The system instantly stops if the clock is lost.

Integrated Circuits (ICs)

The optical clock module uses three types of integrated circuits: multiplexer, differential amplifiers, and divide-by-4 ICs. The multiplexer ICs select one of four paths, based on the input they receive from the control system. The paths are the high-frequency oscillator, low-frequency oscillator, the normal clock frequency oscillator, and the external generator. The differential amplifier ICs amplify the signals going to the OTMs or coming from the control system. The divide-by-4 ICs direct the signal to the trigger source for the respective multiplexer IC. The trigger source ensures an accurate clock signal reference point.

Optical Transmitter Module (OTM)

The OTMs contain the lasers that send the optical signals through the fiber-optic waveguides to the optical receiver on the system modules. The specifications for the lasers are different for the various models of CRAY T90 series systems. Table 1 lists the laser specifications for the OTMs in CRAY T932, CRAY T916, and CRAY T94 systems.

Table 1. CRAY T90 Series OTM Specifications

Specification	System	
	CRAY T932 and CRAY T916 (OH01)	CRAY T94 (OL01)
Rated power	12.229 milliwatt (mW)	2 milliwatt (mW)
Operating peak power	10 mW	1 mW
Operating average power	5 mW	0.5 mW
Wavelength	1290 nm	1300 nm
Pulse frequency	500 MHz nominal, range 400 MHz to 550 MHz	500 MHz nominal, range 400 MHz to 550 MHz

Coupler

The coupler splits the clock signal that comes from the OTM and sends it to the system modules. Two levels of couplers are associated with each optical clock module. In CRAY T94 systems, the coupler on the clock deck is a 2-by-2 coupler: two inputs (coming from the two OTMs) and two outputs (however, only one output is used). This coupler sends the optical clock signal to a 1-by-8 coupler. The 1-by-8 coupler splits the signal and sends it to 8 different system modules.

In CRAY T916 and CRAY T932 systems, the coupler coming off the module is a 4-by-4 coupler in which only two inputs are used (one from each OTM). Only two outputs are used in CRAY T916 systems, and all four outputs are used in CRAY T932 systems (refer to Figure 4). This coupler sends the optical clock signal to a 1-by-24 coupler, which splits the signal and sends it to up to 24 different system modules.

Connectors

The optical clock module has two types of connectors: right-angle head connectors and SMA jacks. Table 2 describes the function of the five different right-angle head connectors. The SMA jacks are the connectors for the external generator source and the trigger source.

Table 2. Right-angle Head Connectors

Connector Description	Connector Name	Connector Function
3-pin	Power	Powers on the optical clock module.
4-pin	Laser Enable	Enables one of two lasers.
5-pin	Laser Alarm	An electrical signal which indicates if the laser is in an operational or non-operational state.
6-pin	Oscillator Path Select	Selects one of four paths: low frequency, high frequency, normal frequency, or external generator.
7-pin	Oscillator Power Select	Powers on the selected oscillator.

CRAY T94 Clock Deck

In CRAY T94 systems, the optical clock module is mounted on a clock deck. The clock deck sits on top of the card cage. The clock deck is a field replaceable unit (FRU) if the coupler fails; however, if the laser board or the oscillator board fails, then the failing board becomes the FRU instead of the clock deck. Refer to Figure 3 for an illustration of the CRAY T94 clock deck. Refer to the *Field Replacement Procedures*, publication number HMM-111-0, for information on how to replace the clock deck, the oscillator board, or the laser board.

Figure 3. CRAY T94 Clock Deck

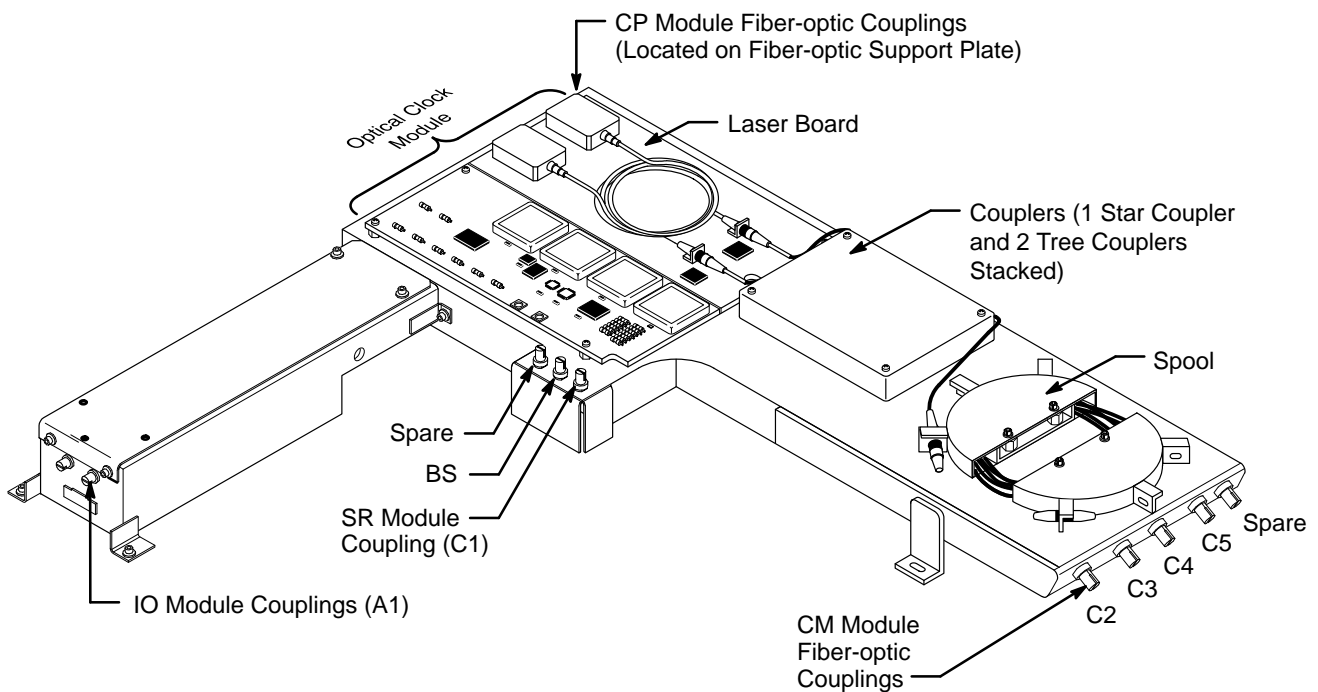

Optical Clock Path

Figure 4 shows the optical clock path for CRAY T94, CRAY T916, and CRAY T932 systems. In CRAY T94 systems, the optical clock module is capable of sending the clock signal to 16 system modules. In CRAY T916 and CRAY T932 systems, the optical clock module is capable of sending the clock signal to up to 96 different system modules. In CRAY T932 systems, each output of the 1-by-24 coupler can connect within any one of the four quadrants of the mainframe.

Figure 4. Optical Clock Path

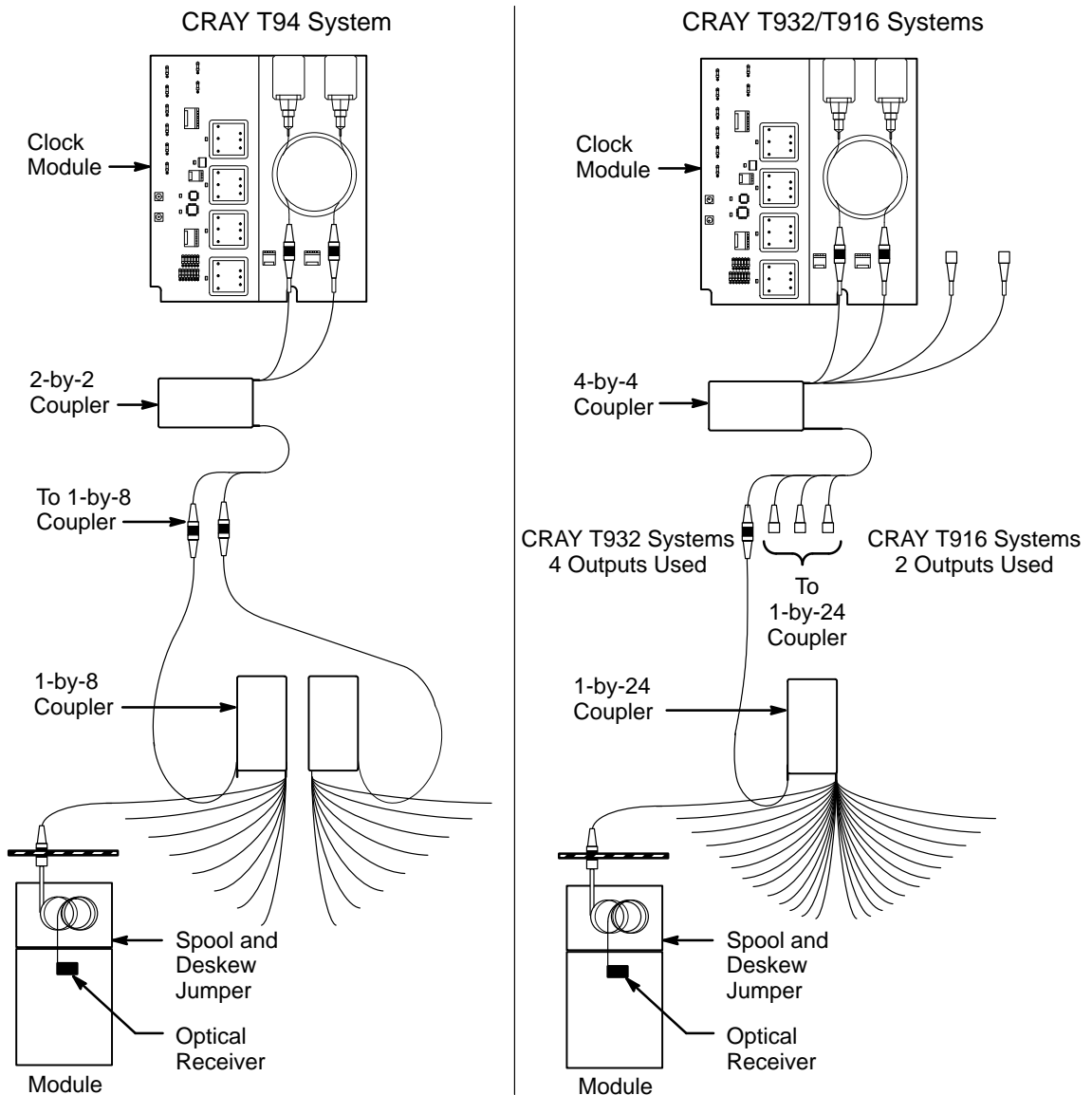
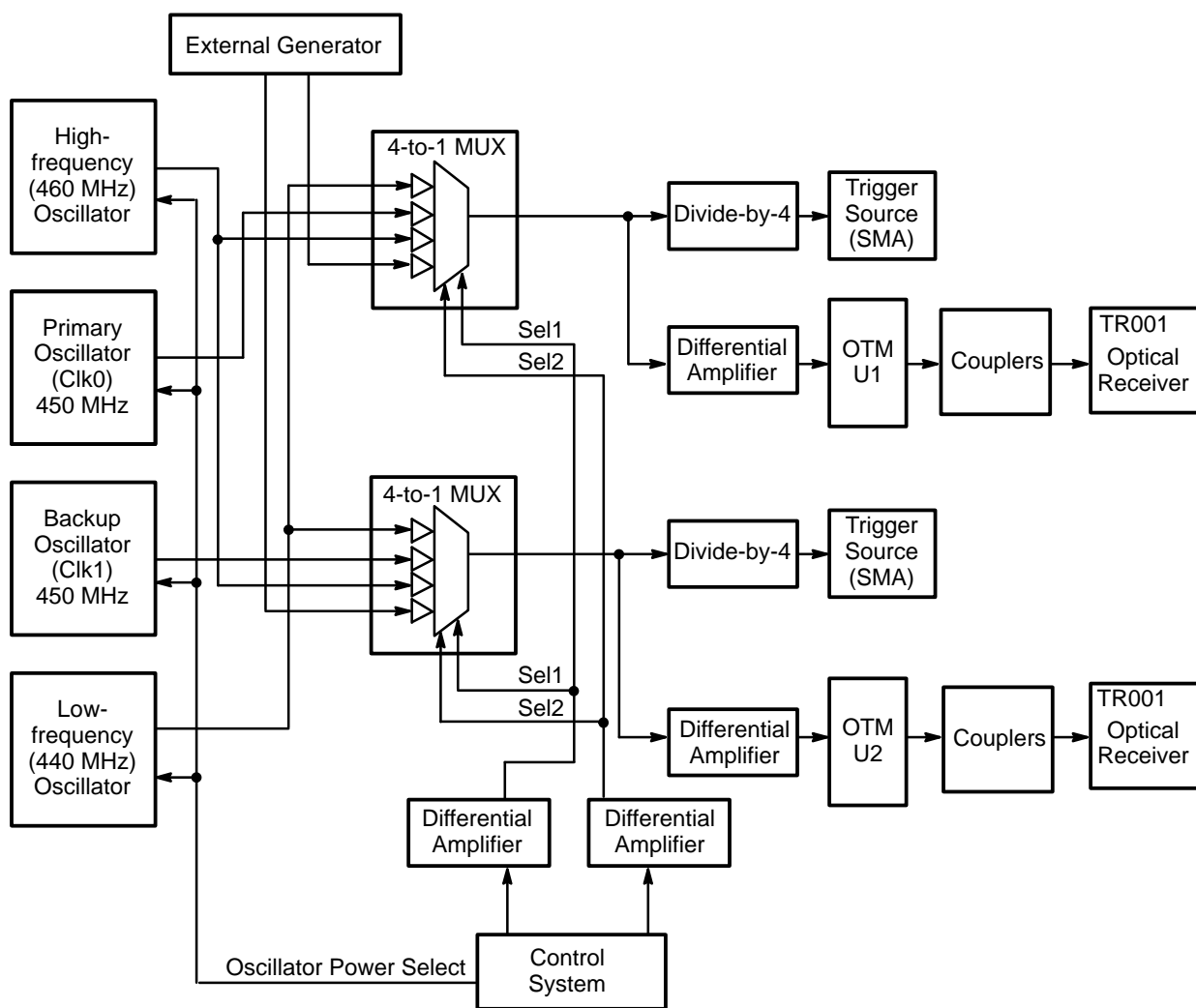

Figure 5 is a block diagram of the optical clock path. The control system sends three signals simultaneously to the optical clock module. One signal selects a path to enable the multiplexer, another signal powers on the specified oscillator or external generator, and a third signal powers on the associated OTM.

The selected oscillator (or external generator) sends an electric clock pulse to the multiplexer. The multiplexer sends the signal through a divide-by-4 IC and a differential amplifier IC. The divide-by-4 IC sends the signal to the trigger source. The differential amplifier IC sends the spool signal to the associated OTM. The OTM converts the electrical signal to an optical signal and then sends it to the optical receiver on the system modules.

Figure 5. Optical Clock Module Block Diagram



Clock Distribution on System Modules

Each system module has an optical receiver (TR001) that converts the optical signal back to an electrical signal. The optical receiver then sends the **T/C clk** signal to the TZ option. The TZ option sends a true and complement copy of this signal to each option on the module. The TP connector receives the **Output T/C Null** signal, which is a deskew point for probing the clock signal on the module. The other 81 TZ option outputs (OAB through ODR) go to the module options and enter the options as a **Clock Input** signal, Boolean term IZY.

The TZ option has forced inputs on 23 different pins (IBA through IBW) for encoding module identification information including the module type and module serial number. The boundary scan register (BSR) obtains this data and uses it for boundary scan functions. For more information on boundary scan and module identification, read the *Boundary Scan Module (BS02)* document, publication number HTM-005-A.

The TZ option also has two forced input signals: **Output Select 0** and **Output Select 1**. These signals allow for four different TZ option output configurations, which turn off unused outputs to help reduce the amount of noise on the module.

Figure 6. System Module Clock Distribution Block Diagram

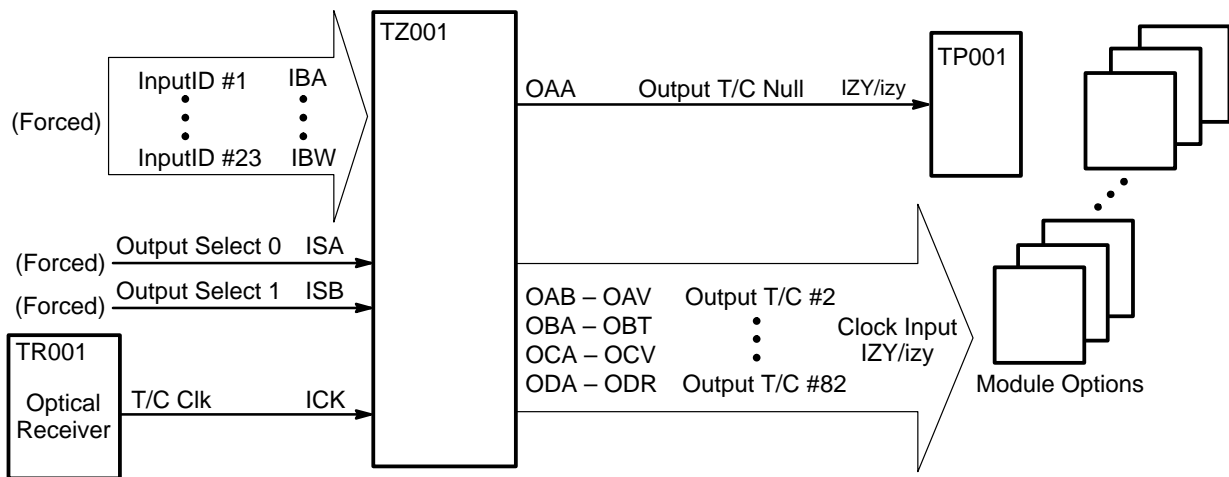

NOTE: Each differential output pair from the TZ option can drive two options on directly opposite sides of a system module.

Laser Safety: CRAY T90 Series Systems as Laser Products

The CRAY T90 series systems are considered laser products because they incorporate a laser on the optical clock module. A laser is capable of producing electromagnetic radiation; therefore, you must follow laser safety procedures when working with the optical clock module.

Lasers are classified by the level of radiation accessible to humans during the operation of the laser or laser product. Table 3 lists the different laser classes and describes their wavelength range and optical power accession limits. The accession limit is the maximum rating or sudden outburst possible from the specified laser class. Note that a Class I laser is the safest type of laser or laser product.

Table 3. Laser Classes

Class	Wavelength Range	Accession Limits
I	180 nm to 10^6 nm	Varies with λ and exposure time
Ila	400 nm to 710 nm	3.9×10^{-6} W (3.9 microwatts)
II	400 nm to 710 nm	1.0×10^{-3} (1.0 milliwatt)
IIla	400 nm to 710 nm	5.0×10^{-3} (5.0 milliwatts)
IIIb	180 nm to 400 nm	Varies with λ and exposure time
	400 nm to 10^6 nm	0.5 watt

The lasers on the optical clock module are Class IIIb lasers; the manufacturer establishes this classification. However, when Cray Research, Inc. (CRI) incorporates these lasers into the CRAY T90 series systems, the laser product (or CRAY T90 series system) is considered a Class I laser product. This is because the classification is determined by the amount of radiation exposure during system operation. During the operation of a CRAY T90 series system, all of the laser light is confined to the fiber-optic waveguides in the system. No laser light radiates outside of these fiber-optic waveguides; therefore, no laser light radiates outside of the mainframe cabinet.

NOTE: If a CRAY T932 system is degraded for maintenance purposes, the degraded portion of the system still receives the clock signal. Be sure to follow all laser safety procedures when you replace modules or perform system maintenance on a degraded CRAY T932 system.

If you ever apply power to the optical clock module when it is not enclosed in the mainframe cabinet (STCO and Engineering only), or if you are maintaining a degraded CRAY T932 system, be sure to follow these guidelines to ensure safety:

- Read and follow the information on all caution/warning/danger labels before you apply power to the module. Figure 7 illustrates a sample caution label for a laser product.

Figure 7. Sample Caution Label for a Class I Laser Product

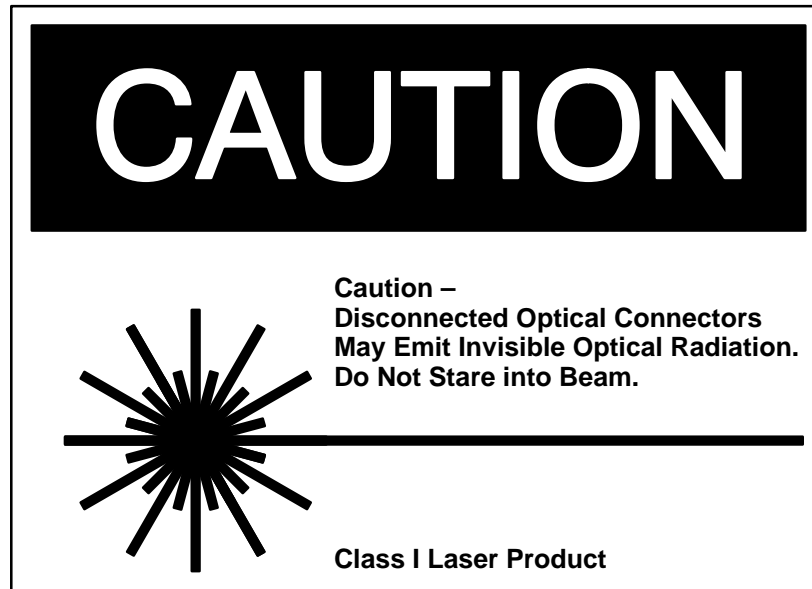

- Always attach the connector to the fiber before you apply power to the module. This ensures that all light is confined within the fiber-optic waveguide, practically eliminating any potential hazard.
- Never look into the end of a fiber to see whether light is being emitted. Most fiber-optic laser wavelengths (1300 nm and 1550 nm) are invisible to the eye and will cause permanent damage. Shorter wavelength lasers (for example 780 nm) are visible and are very damaging. Always use an optical power meter to verify light output.
- Never look into the end of a fiber on a powered device with any type of magnifying device such as a microscope, eye loupe, or magnifying glass. This will cause a permanent, irreversible burn on your retina.
- Call the manufacturer with any questions about laser safety before you apply power to the optical clock module.

If you are ever exposed to or injured from laser radiation, be sure to fill out a Health Incident Report and submit it (within 24 hours of the incident) to the Cray Research Environmental Health and Safety department in Chippewa Falls, Wisconsin.