

**CRAY T90™ Series
Hardware Reference Booklet**

CQH-0302-0F0

Cray Research/Silicon Graphics Proprietary



Any shipment to a country outside of the United States requires a letter of assurance from Cray Research, Inc.

This document is the property of Cray Research, Inc. (CRI). The use of this document is subject to specific license rights extended by Cray Research, Inc. to an employee of Cray Research, Inc. or other licensed party according to the terms and conditions of the license and for no other purpose.

Cray Research, Inc. Unpublished Proprietary Information — All Rights Reserved.

Autotasking, CF77, CRAY, CRAY-1, Cray Ada, CraySoft, CRAY Y-MP, CRInform, CRI/*Turbo*Kiva, HSX, LibSci, MPP Apprentice, SSD, SUPERCLUSTER, UNICOS, and X-MP EA are federally registered trademarks and Because no workstation is an island, CCI, CCMT, CF90, CFT, CFT2, CFT77, ConCurrent Maintenance Tools, COS, CRAY-2, Cray Animation Theater, CRAY APP, CRAY C90, CRAY C90D, Cray C++ Compiling System, CrayDoc, CRAY EL, CRAY J90, CRAY J90se, CrayLink, Cray NQS, Cray/REELibrarian, CRAY S-MP, CRAY SSD-T90, CRAY T3D, CRAY T3E, CRAY T3E-900, CRAY T90, CrayTutor, CRAY X-MP, CRAY XMS, CSIM, CVT, Delivering the power . . . , DGauss, Docview, EMDS, GigaRing, HEXAR, IOS, ND Series Network Disk Array, Network Queuing Environment, Network Queuing Tools, OLNET, RQS, SEGLDR, SMARTE, SUPERLINK, System Maintenance and Remote Testing Environment, Trusted UNICOS, UNICOS MAX, and UNICOS/mk are trademarks of Cray Research, Inc.

Silicon Graphics and the Silicon Graphics logo are registered trademarks and Origin and Origin2000 are trademarks of Silicon Graphics, Inc. (SGI).

Annex and MicroAnnex are trademarks of Bay Networks, Inc. Lantronix is a trademark of Lantronix.

Direct requests for copies of Cray Research, Inc. publications to:
CRAY RESEARCH, INC.
Customer Service Logistics
1100 Lowater Road
P. O. Box 4000
Chippewa Falls, WI 54729-0078 USA

Comments about this publication should be directed to:
CRAY RESEARCH, INC.
Service Publications and Training
890 Industrial Blvd.
P.O. Box 4000
Chippewa Falls, WI 54729-0078 USA

Record of Revision

Each time this booklet is revised and reprinted, all changes issued against the previous version are incorporated into the new version, and the new version is assigned an alphabetic level, which is indicated in the publication number on each page of the booklet.

Changes to part of a page are indicated by a change bar in the margin directly opposite the change. A change bar in the footer indicates that most, if not all, of the page is new. If the booklet is rewritten, the revision level changes but the booklet does not contain change bars.

Revision	Description
-----------------	--------------------

	May 1995. Original printing.
A	June 1995. Corrects references to chassis quadrants and CPU numbering and adds module maps for CP02 and shared modules.
B	July 1995. Corrects references to chassis quadrants and CPU numbering.
C	October 1995. Corrects references to chassis map for CRAY T916 memory module numbering.
D	June 1996. Adds information about the CM03, IO02, and CPE1 modules, and EZIF controller error codes.
E	March 1997. Adds information about the MWS and OWS cabling and the network module.
F	April 1998. Adds information about the CM04 module, EZIF connector numbering, and SWS cabling.

This page is intentionally left blank.

CRAY T90 Series Hardware Reference Booklet

Troubleshooting Information **4**

Block Diagram for CP02 Module	5
Block Diagram for CPE1 Module	6
Exchange Package	7
Status Registers for CP02 Module	8
Status Registers for CPE1 Module	9
Destination Codes	10
Syndrome Chart for 1 Bit in Error	11
Syndrome Chart for 2 Bits (1 Byte) in Error	12
Syndrome Decoding Rules	13
EZIF Error Messages	14
Module Chassis Map for CRAY T932 System	17
Module Chassis Map for CRAY T916 System	18
Module Chassis Map for CRAY T94 System	19

Memory **20**

CRAY T94 Memory Chassis Map	20
CRAY T94 Bank Layout for CM02 Module	21
CRAY T94 Bank Layout for Synchronous CM03 Module	22
CRAY T94 Bank Layout for Asynchronous CM03 Module	23
CRAY T94 Bank Layout for CM04 Module	24
CRAY T94 Memory Address for CM02 Module	25
CRAY T94 System Configuration for CM02 Module	25
CRAY T94 Memory Address for Synchronous CM03 Module	26
CRAY T94 System Configuration for Synchronous CM03 Module	26
CRAY T94 Memory Address for Asynchronous CM03 Module	26
CRAY T94 System Configuration for Asynchronous CM03 Module	26
CRAY T94 Memory Address for CM04 Module	27
CRAY T94 System Configuration for CM04 Module	27
CRAY T916 Memory Chassis Map	28
CRAY T916 Bank Layout for CM02 Module	29
CRAY T916 Bank Layout for Synchronous CM03 Module	30
CRAY T916 Bank Layout for Asynchronous CM03 Module	31
CRAY T916 Bank Layout for CM04 Module	32
CRAY T916 Memory Address for CM02 Module	33
CRAY T916 System Configuration for CM02 Module	33

CRAY T916 Memory Address for Synchronous CM03 Module .	34
CRAY T916 System Configuration for Synchronous CM03 Module	34
CRAY T916 Memory Address for Asynchronous CM03 Module	35
CRAY T916 System Configuration for Asynchronous CM03 Module	35
CRAY T916 Memory Address for CM04 Module	36
CRAY T916 System Configuration for CM04 Module	36
CRAY T932 Memory Chassis Map	37
CRAY T932 Bank Layout for CM02 Module	38
CRAY T932 Bank Layout for Synchronous CM03 Module	39
CRAY T932 Bank Layout for Asynchronous CM03 Module.	40
CRAY T932 Bank Layout for CM04 Module	41
CRAY T932 Memory Address for CM02 Module	42
CRAY T932 System Configuration for CM02 Module	42
CRAY T932 Memory Address for Synchronous CM03 Module .	43
CRAY T932 System Configuration for Synchronous CM03 Module	43
CRAY T932 Memory Address for Asynchronous CM03 Module	44
CRAY T932 System Configuration for Asynchronous CM03 Module	44
CRAY T932 Memory Address for CM04 Module	45
CRAY T932 System Configuration for CM04 Module	45
Bit Layout for CM02 Module.	46
Bit Layout for Synchronous CM03 Memory Module.	47
Bit Layout for Asynchronous CM03 Memory Module.	48
Bit Layout for CM04 Memory Module.	49

Connectors 50

SIB Connector Layout	50
SIB EZIF Connector Numbering Sequence (Detail B)	51
SIB EZIF Connector Numbering Sequence (Detail D)	52
SIB EZIF Connector Numbering Sequence (Detail C)	53
SIB EZIF Connector Numbering Sequence (Detail E)	54
Edge Connector for CM02/03 Viewed from Layer 1	55
Maintenance Connector for CM02/03	56
MSC Flex Connector for CM02 Viewed from Layer 1	57
MSC Flex Connector for CM03 Viewed from Layer 1	57
MSC Flex Connector for CM04 Viewed from Layer 1	58
Chip Pinouts	58
Cable Bulkhead for CRAY T94 System (IO01 Module)	59
Cable Bulkhead for CRAY T94 System (IO02 Module)	60

Node/Quad Assignments for IO02 Module (Upright)	61
Node/Quad Assignments for IO02 Module (Inverted) at Chassis Locations E1, M1	61
Cable Bulkhead for CRAY T916 and CRAY T932 Systems (IO02 Module)	62
IO1/2 Fuzz-button Connector Pin Assignments	63
I/O Channel Assignments (CRAY T94 System)	64
I/O Channel Assignments (CRAY T916 System)	65
I/O Channel Assignments (CRAY T932 System)	66
Boundary Scan Connector Layout	67
Boundary Scan Module Connectors for CRAY T94 System	68
Boundary Scan Module Connectors for CRAY T916 and CRAY T932 Systems (Quadrants 0 and 1)	69
Boundary Scan Module Connectors for CRAY T932 System (Quadrants 2 and 3)	70
MWS Connectors	71
OWS Connectors	71
SWS Connectors	72
Micro Annex Connectors	72
Lantronix Concentrator Connectors	73

Module Maps **74**

CP02 Module Board 1	74
CP02 Module Board 2	75
CPE1 Module Board 1	76
CPE1 Module Board 2	77
SR01 Module Board 1	78
SR01 Module Board 2	79
CM02 Module Board 1	80
CM02 Module Board 2	81
CM03 Module Board 1	82
CM03 Module Board 2	83
CM04 Module Board 1	84
CM04 Module Board 2	85
IO01 Module Board 1	86
IO01 Module Board 2	87
IO02 Module Board 1	88
IO02 Module Board 2	89
NW01 Module Board 1	90
NW01 Board 2	91

Notes **92**

Troubleshooting Information

This section contains module block diagrams, syndrome charts, and module chassis maps.

Block Diagram for CP02 Module

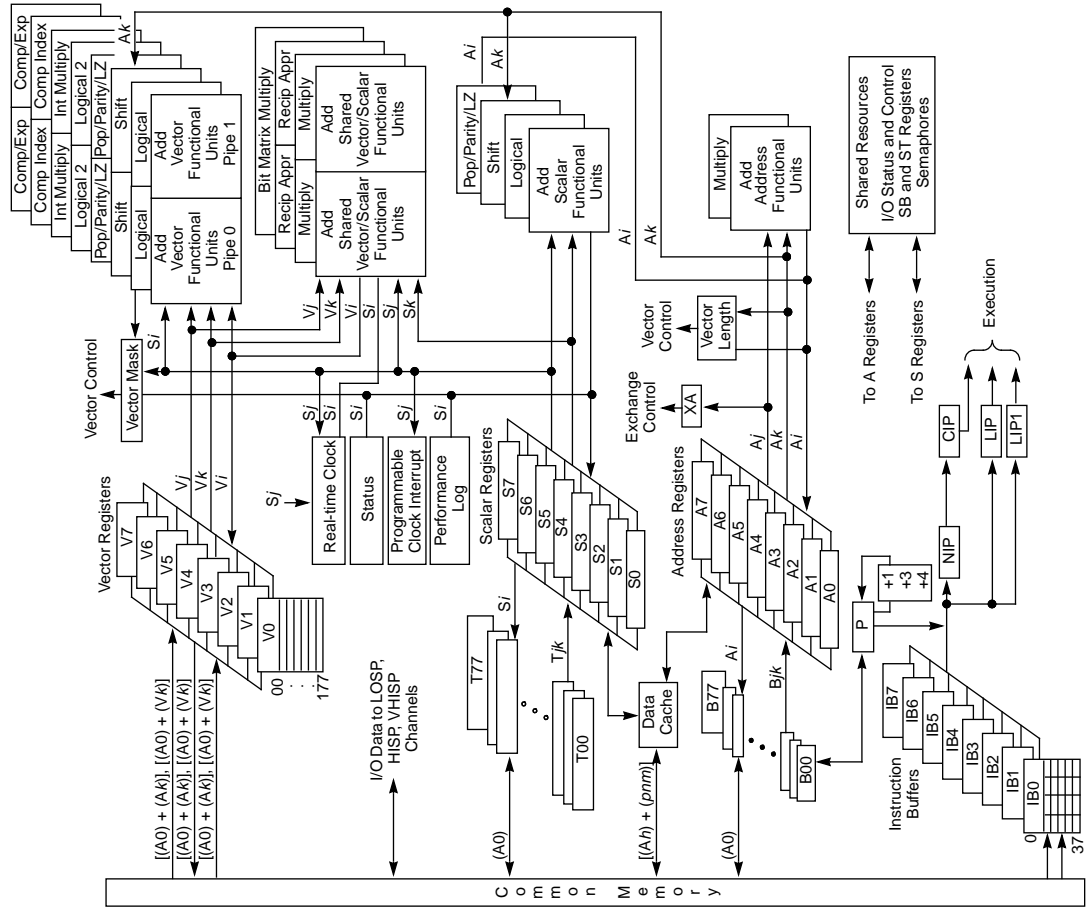

Block Diagram for CPE1 Module

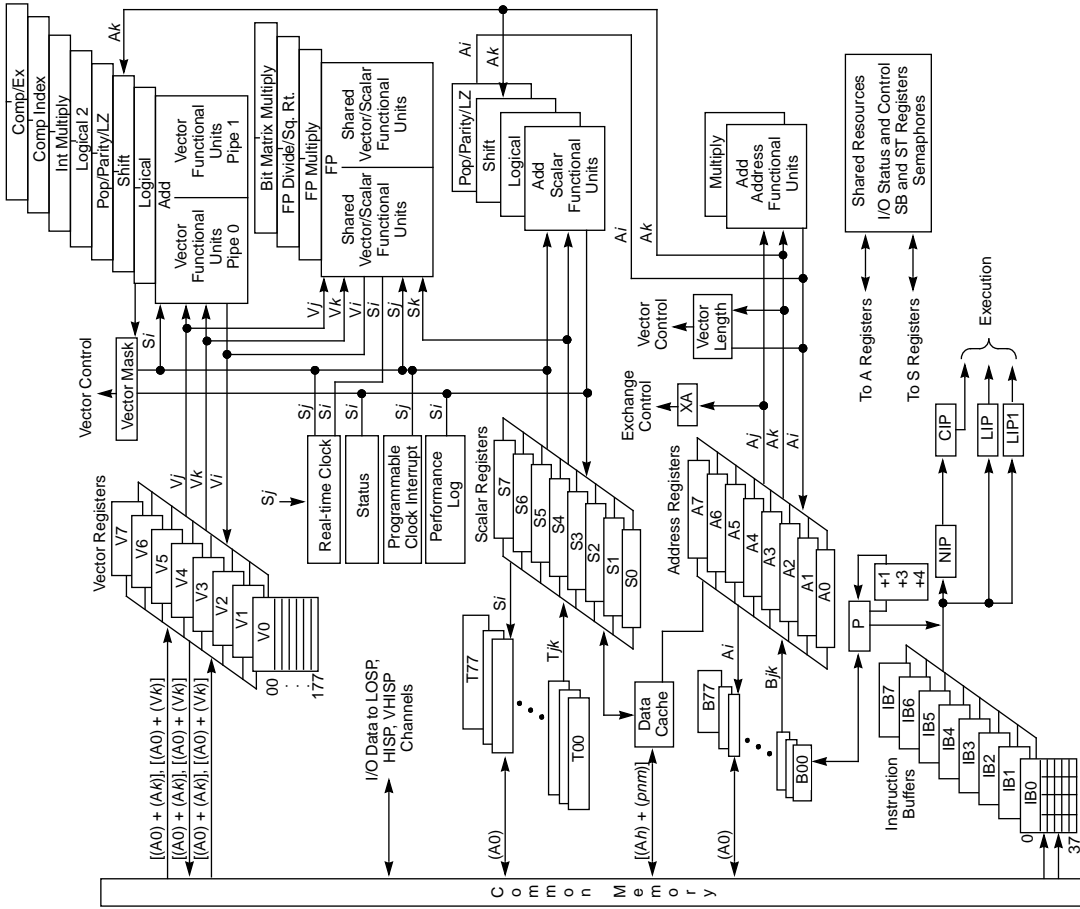

Exchange Package

Interrupt Modes

INV	FP invalid ^b
IDV	FP divide by zero ^b
IOV	FP overflow ^b
IUN	FP underflow ^b
INX	FP not exact ^b
IXI	FP exceptional input ^b
IAM	Address multiply range error ^b
FNX	Enable flag on normal exit
IMI	001ij ≠ 0 or 033 instruction
IDL	Deadlock
IPC	Programmable Clock
IIO	I/O
IIP	Interprocessor interrupt
IRT	Real-time clock
IMC	MCU interrupt
ICM	Correctable memory error
IBP	Breakpoint
FEX	Enable flag on error exit
IPR	Program range error
IOR	Operand range error
IFP	Floating-point error ^a
IUM	Uncorrectable memory error
IRP	Register parity error

^a Not used in CPE1 Module

^b Not used in CP02 Module

Memory - Absolute																	
ADX	00000000000100																
P	000010135c	A0	000000	000000	000000	000000	50	000000	000000	000000	000000						
PN	000	A1	000000	000000	000000	000000	51	000000	000000	000000	000000						
XA	0006000	A2	000000	000000	000000	000000	52	000000	000000	000000	000000						
EA0	0006000	A3	000000	000000	000000	000000	53	000000	000000	000000	000000						
EA1	0006000	A4	000000	000000	000000	000000	54	000000	000000	000000	000000						
EA2	0006000	A5	000000	000000	000000	000000	55	000000	000000	000000	000000						
EA3	0006000	A6	000000	000000	000000	000000	56	000000	000000	000000	000000						
E#4	0006000	A7	000000	000000	000000	000000	57	000000	000000	000000	000000						
CN	000	MODES	000	BR	RST	EBM	IM	00000000	II	III	FII	III	III	IFI	III	III	
VL	000			DM	MCR	SDM			RU	FOP	EBC	MRI	IPD	MNA	XNU	ODN	
				D1	OEI	LM			PM	PRR	XPM	CTP	OCL	IXM	IXX	VVV	
STATUS	00	XNU	ODN	000	SS	**V	FWB	IF	00000000	RM	FOP	EBM	MRI	IPD	MNA	XNU	ODN
		IXN	VVV		BB	**N	PSM			PE	PRR	EPE	CTC	OCL	IEM	IXN	VIV
		SSS	SSS		MJ	**U	S L			EU	EEE	XIC	UIP	II	IXI	F	FVI

Modes

MM	Monitor mode
BDM	Bi-directional memory
ESL	Enable 2nd vector logical
TRI	Triton mode ^a
SCE	Scalar cache enable
RM0	FP rounding mode Bit 0
RM1	FP rounding mode bit 1
BDD	Bi-directional disable

Status

BML	Bit matrix multiply loaded
WS	Waiting on semaphore
FPS	FP error status ^a
VNU	Vectors not used
SBU	Status bit - monitor mode
SBM	Status bit - user mode
NVS	FP invalid ^b
DVS	FP divide by zero ^b
OVS	FP overflow ^b
UNS	FP underflow ^b
NXS	FP not exact ^b
XIS	FP exceptional input ^b

Status Registers for CP02 Module

Bits	63	57	52	48	47	40	39	32	31	16	15	0				
SR0	C L N #0		B M L		I F I I B B P F O D M P S P R M Y		Processor Number		Cluster Number		a					
SR1																
SR2	Performance Monitors 0 - 17															
SR3	Performance Monitors 20 - 37															
SR4	Error Type Destination Code															
SR5	Error Syndrome															
SR6	Error Address															
SR7	LAT Faults ^b				S R P R E				RPE Chip Number				SRRE Chip Number			
	Multiple Hit				Miss											
	D C' C B' B A' A				D C' C B' B A' A											
Bits	63	61	55	54	48	47	46	43	32	31	24	16	15	0		

^a SR0 bit 0 = monitor mode - maintenance mode - not (SR7 busy)

^b SR7 bits 48 - 61 are set when a LAT fault occurs on the specified memory port

NOTES: Undefined areas can contain any value.
Status register read instruction 073j/1 Si SRj (Reading SR2 - SR7 is privileged to monitor mode.)

Destination Codes

Destination	Bit													
	13	12	11	10	9	8	7	6	5	4	3	2	1	0
Cache read	1	1	1	-	Word									
V register read	1	1	0	Register	-	Element								
S register read	1	0	1	Register	0	-								
A register read	1	0	1	Register	1	-								
T register read	1	0	0	-	0	-	Register							
B register read	1	0	0	-	1	-	Register							
Fetch read	0	1	1	Group	-					Word				
I/O read	0	1	0	Type	-					Word				
Exchange read	0	0	1	-					Word					
I/O write	0	0	0	Type	1	-								
Processor write	0	0	0	-	0	1	0	A/S	-					
Reconfigure	0	0	0	-	1	1	0	-						
Memory error	0	0	0	-	0	0	0	-						

NOTE: These codes are on Status Register 4, bits 32 - 45.
They show the destination for the data on a memory read.

Syndrome Chart for 1 Bit in Error

Syndrome	Bit	Syndrome	Bit	Syndrome	Bit	Syndrome	Bit	Syndrome	Bit
0001	64	0501	32	2021	43	3321	47	5170	57
0002	67	0504	33	2024	6	3612	20	5200	55
0004	65	0520	34	2120	11	3621	46	5212	19
0010	68	0525	35	2125	13	4000	75	5242	61
0020	66	0555	37	2133	15	4012	18	5250	56
0025	7	0571	36	2136	14	4042	59	5330	58
0040	69	1000	74	2401	44	4050	22	5505	5
0052	23	1012	17	2420	38	4240	27	5542	63
0100	70	1202	48	2425	8	4247	30	6426	10
0105	0	1210	49	2500	39	4252	29	6612	21
0124	12	1236	52	2505	3	4255	31	7051	25
0200	73	1240	50	2521	45	4427	9	7105	4
0212	16	1252	51	2524	40	4742	62	--	--
0250	28	1266	53	2664	42	5002	60	--	--
0400	71	2000	72	2744	41	5040	54	--	--
0405	1	2005	2	3053	26	5052	24	--	--

Syndrome Chart for 2 Bits (1 Byte) in Error

Syndrome	Bits	Syndrome	Bits	Syndrome	Bits	Syndrome	Bits	Syndrome	Bits	Syndrome	Bits
0003	64, 67	1417	1, 17	3476	9, 25	6366	15, 31	7634	41, 57		
0014	65, 68	1703	32, 48	4717	4, 20	6371	14, 30	7700	39, 55		
0060	66, 69	1714	33, 49	5475	10, 26	6663	47, 63	7717	3, 19		
0077	7, 23	1733	37, 53	6000	72, 75	7163	46, 62	7763	45, 61		
0300	70, 73	1747	36, 52	6017	2, 18	7403	44, 60	7774	40, 56		
0317	0, 16	1760	34, 50	6063	43, 59	7460	38, 54	6377	13, 29		
0374	12, 28	1777	35, 51	6074	6, 22	7477	8, 24	--	--		
1400	71, 74	3317	5, 21	6360	11, 27	7554	42, 58	--	--		

Syndrome Decoding Rules

Syndrome Rule	Example: Syndrome Bytes ^a					Error Description	
	5	4	3	2	1		0
Syndrome = 0	0	0	0	0	0	0	No error occurred.
Even number of bytes in error	00	00	01	00	01	00	Double- or multiple-byte error.
1 byte is in error	00	01	00	00	00	00	Checksum error. The byte indicates which check bits are in error.
3 or 5 bytes are in error	00	01	01	00	00	01	Single-byte error in data field.

^a 00 = Good Byte
01, 10, 11 = Bad Byte

EZIF Error Messages

Error Message	Cause	Action
No Current Flow!! Reading Was: <voltage>mV Minimum Limit: 1mV.	Actuator cable open or disconnected. Heater loop open. Controller failure.	Check actuation cable connection and replace if necessary. Troubleshoot heater loop. Replace controller.
Excess Current Draw!! Reading Was: <voltage>mV. Maximum Limit: 220mV.	Heater loop shorted. Controller failure. Heater being cooled by some means.	Troubleshoot heater loop. Replace controller. Ensure that the system is completely pumped down so that the connectors are not in contact with the dielectric coolant.
Regulation Fault!! Reading Was: <voltage>mV. Maximum Limit: <200 or 170> mV	Heater loop shorted. Controller failure. Heater being cooled by some means.	Troubleshoot heater loop. Replace controller. Ensure that the system is completely pumped down so that the connectors are not in contact with the dielectric coolant.
Regulation Fault!! Reading Was: <voltage>mV. Maximum Limit: 130 mV	Heater loop shorted. Controller failure. Heater being cooled by some means	Troubleshoot heater loop. Replace controller. Ensure that the system is completely pumped down so that the connectors are not in contact with the dielectric coolant.
Regulation Fault!! Reading Was: <voltage>mV. Maximum Limit: <upper_limit>mV.	Heater loop shorted. Controller failure. Heater being cooled by some means.	Troubleshoot heater loop. Replace controller. Ensure that the system is completely pumped down so that the connectors are not in contact with the dielectric coolant.

EZIF Error Messages

Error Message	Cause	Action
Regulation Time-out!! Reading Was: <voltage>mV. Maximum Limit: <160 or 170>mV.	Heater loop shorted. Controller failure. Heater being cooled by some means.	Troubleshoot heater loop. Replace controller. Ensure that the system is completely pumped down so that the connectors are not in contact with the dielectric coolant.
PRI=Bad SEC=Bad	Primary/Secondary heater matched the configuration for the selected module; resistance errors occurred.	Troubleshoot heater loop.
PRI=Open SEC=Open	Primary/Secondary heater did not match the configuration for the selected module; all pins measure open.	Troubleshoot heater loop.
PRI=CM/IO4/SR4/SIB4 SEC=CM/IO4/SR4/SIB4	Primary/Secondary heater did not match the configuration for the selected module; it matched the configuration for a CM, IO4, SR4, or SIB4 module.	Troubleshoot heater loop.
PRI=CP SEC=CP	Primary/Secondary heater did not match the configuration for the selected module; it matched the configuration for a CP module.	Troubleshoot heater loop.
PRI=NW SEC=NW	Primary/Secondary heater did not match the configuration for the selected module; it matched the configuration for an NW module.	Troubleshoot heater loop.

EZIF Error Messages

Error Message	Cause	Action
PRI=SR8 SEC=SR8	Primary/Secondary heater did not match the configuration for the selected module; it matched the configuration for an SR8 module.	Troubleshoot heater loop.
PRI=SIB5 SEC=SIB5	Primary/Secondary heater did not match the configuration for the selected module; it matched the configuration for an SIB5 module.	Troubleshoot heater loop.
PRI=CPIO/Single SEC=CPIO/Single	Primary/Secondary heater did not match the configuration for the selected module; it matched the configuration for a CPIO/single module.	Troubleshoot heater loop.
PRI=Invalid SEC=Invalid	Primary/Secondary heater did not match the configuration for the selected module or any other module.	Troubleshoot heater loop.

Module Chassis Map for CRAY T932 System

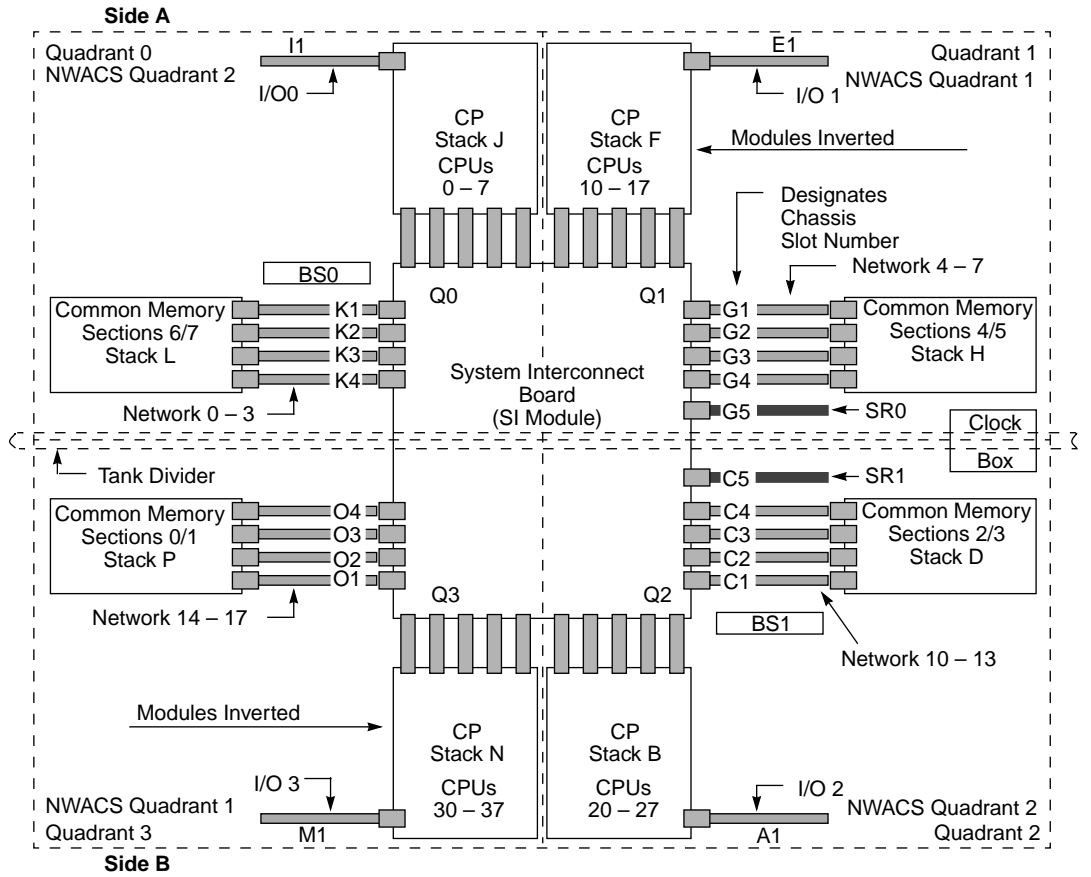

Module Chassis Map for CRAY T916 System

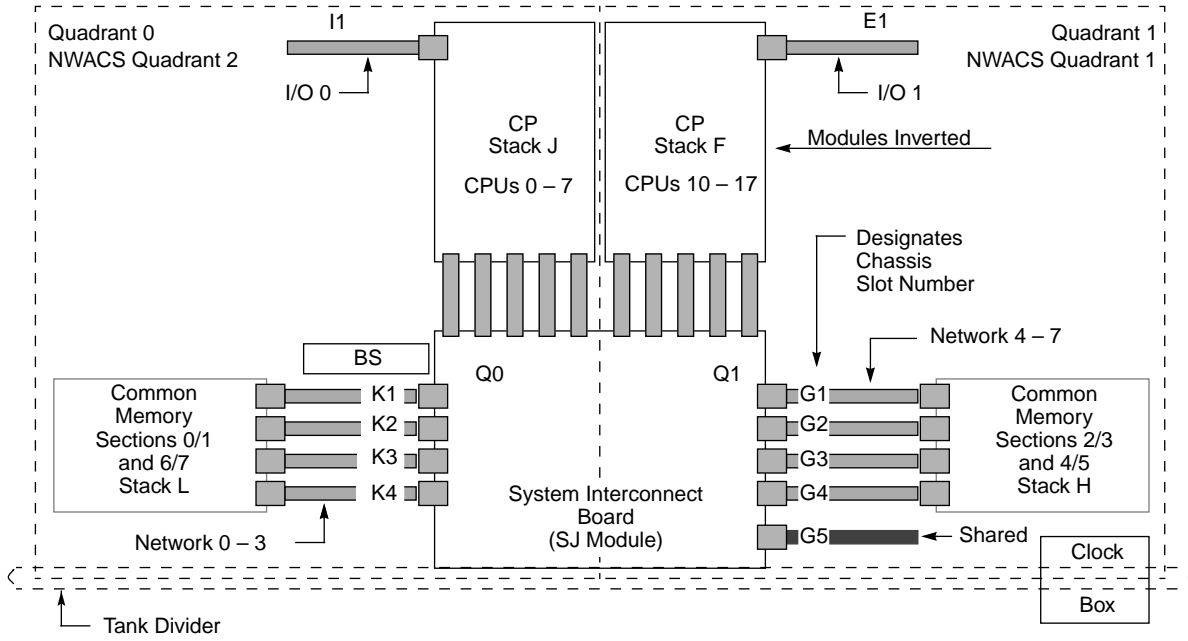

Module Chassis Map for CRAY T94 System

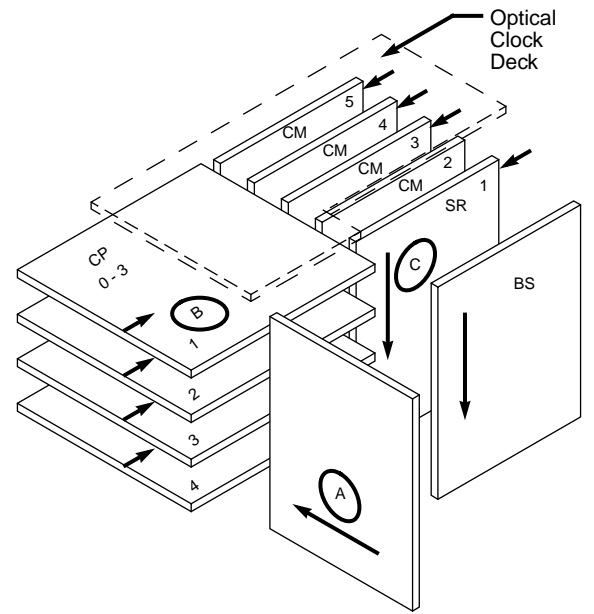

NOTE: Arrows indicate direction of module insertion into the chassis.

Memory

CRAY T94 Memory Chassis Map

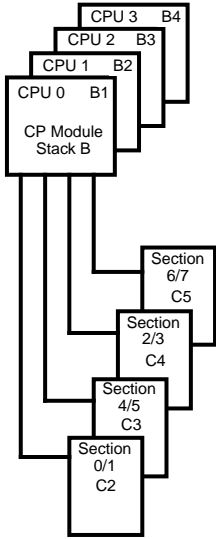

CRAY T94 Bank Layout for CM02 Module

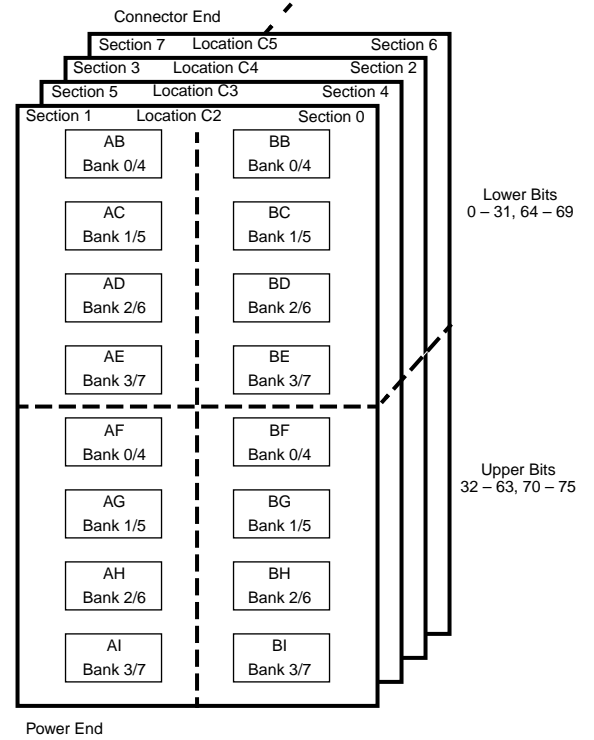

CRAY T94 Bank Layout for Synchronous CM03 Module

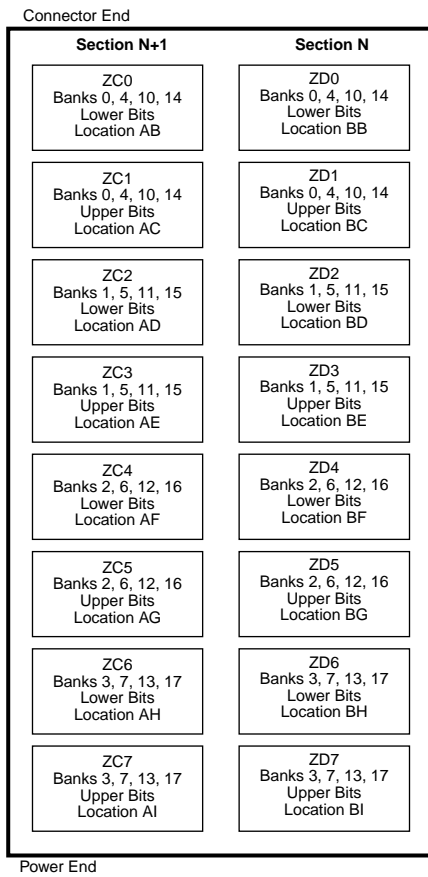

CRAY T94 Bank Layout for Asynchronous CM03 Module

Connector End

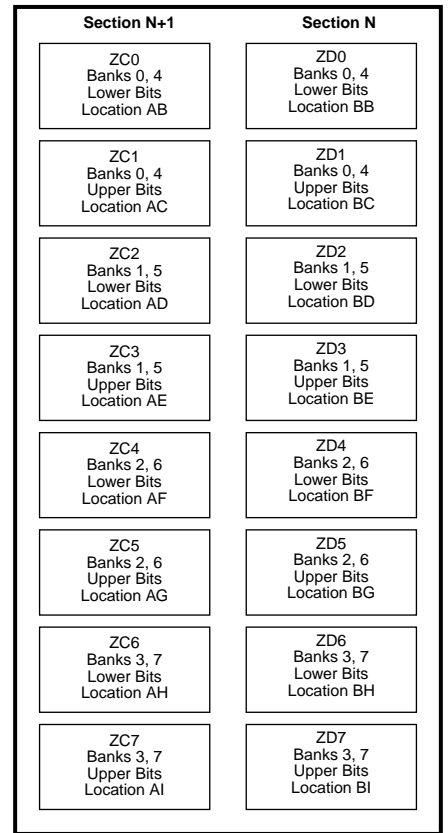

Power End

CRAY T94 Bank Layout for CM04 Module

Connector End

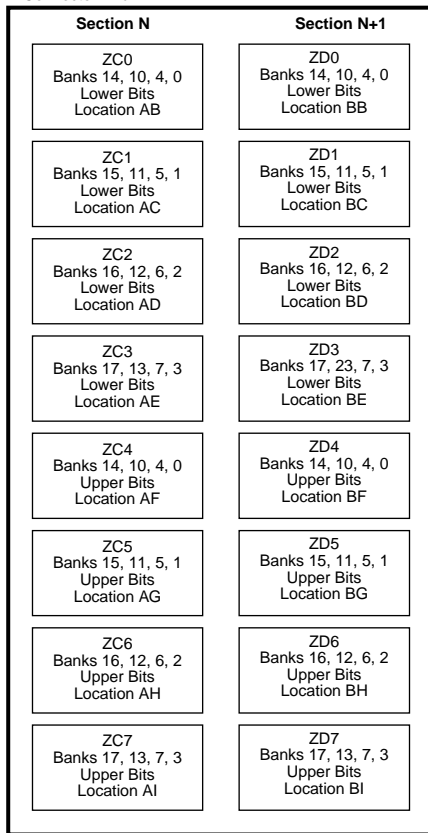

Power End

CRAY T94 Memory Address for CM02 Module

Bits	30	27	26		6	5		3	2	0
	Not Used		Word Select			Bank Select		Section Select		

CRAY T94 System Configuration for CM02 Module

Module Counts			Configuration				Address Bits			
Processor	Network	Memory	Sections	Subsections	Banks	Mwords	Section	Subsection	Bank	Word
1 to 4	0	4	8	1	64	128	00, 01, 02	-	03, 04, 05	06 – 30
1 to 4	0	4	8	1	32	64	00, 01, 02	-	03, 04	05 – 29
1 to 4	0	2	4	1	32	64	00, 01	-	02, 03, 04	05 – 29
1 to 4	0	2	4	1	16	32	00, 01	-	02, 03	04 – 28

CRAY T94 Memory Address for Synchronous CM03 Module

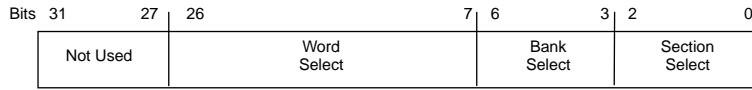

CRAY T94 System Configuration for Synchronous CM03 Module

Module Counts			Configuration				Address Bits			
Processor	Network	Memory	Sections	Subsections	Banks	Mwords	Section	Subsection	Bank	Word
1 to 4	0	4	8	1	128	128	00, 01, 02	-	03, 04, 05, 06	07-31
1 to 4	0	4	8	1	64	64	00, 01, 02	-	03, 04, 05	06-30
1 to 4	0	2	4	1	64	64	00, 01	-	02, 03, 04, 05	06-30
1 to 4	0	2	4	1	32	32	00, 01	-	02, 03, 04	05-29

CRAY T94 Memory Address for Asynchronous CM03 Module

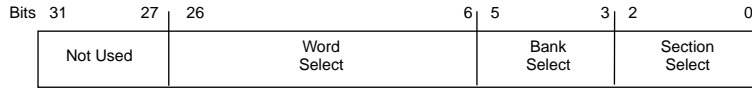

CRAY T94 System Configuration for Asynchronous CM03 Module

Module Counts			Configuration				Address Bits			
Processor	Network	Memory	Sections	Subsections	Banks	Mwords	Section	Subsection	Bank	Word
1 to 4	0	4	8	1	64	128	00, 01, 02	-	03, 04, 05	06-31
1 to 4	0	4	8	1	32	64	00, 01, 02	-	03, 04	05-30
1 to 4	0	2	4	1	32	32	00, 01, 02	-	02, 03, 04	05-30
1 to 4	0	2	4	1	16	32	00, 01	-	02, 03	04-29

CRAY T94 Memory Address for CM04 Module

Bits 31	28	27	7	6	3	2	0
Not Used		Word Select			Bank Select		Section Select

CRAY T94 System Configuration for CM04 Module

Module Counts			Configuration				Address Bits			
Processor	Network	Memory	Sections	Subsections	Banks	Mwords	Section	Subsection	Bank	Word
1 to 4	0	4	8	1	128	256	00, 01, 02	-	03, 04, 05, 06	07 – 31
1 to 4	0	4	8	1	64	128	00, 01, 02	-	03, 04, 05	06 – 30
1 to 4	0	2	4	1	64	128	00, 01	-	02, 03, 04, 05	06 – 30
1 to 4	0	2	4	1	32	64	00, 01	-	02, 03, 04	05 – 29

CRAY T916 Memory Chassis Map

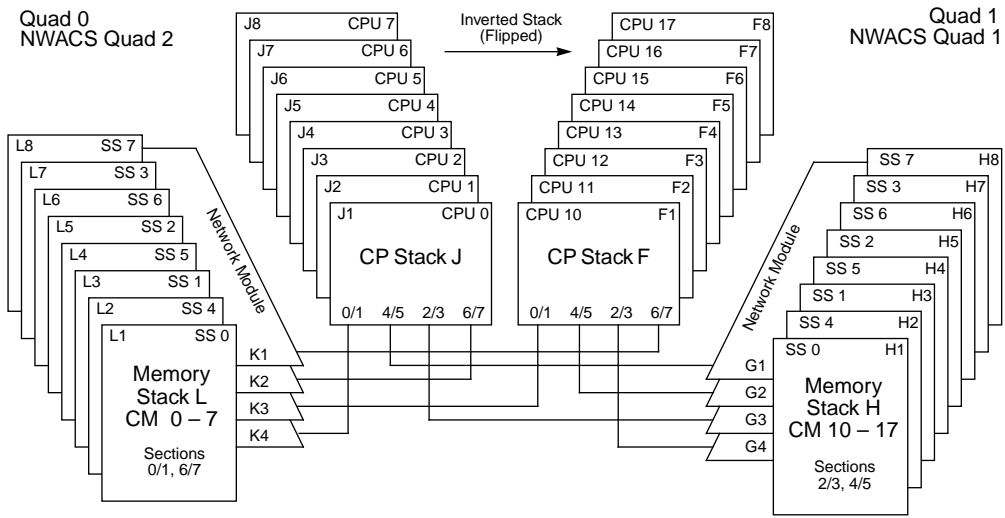

CRAY T916 Bank Layout for CM02 Module

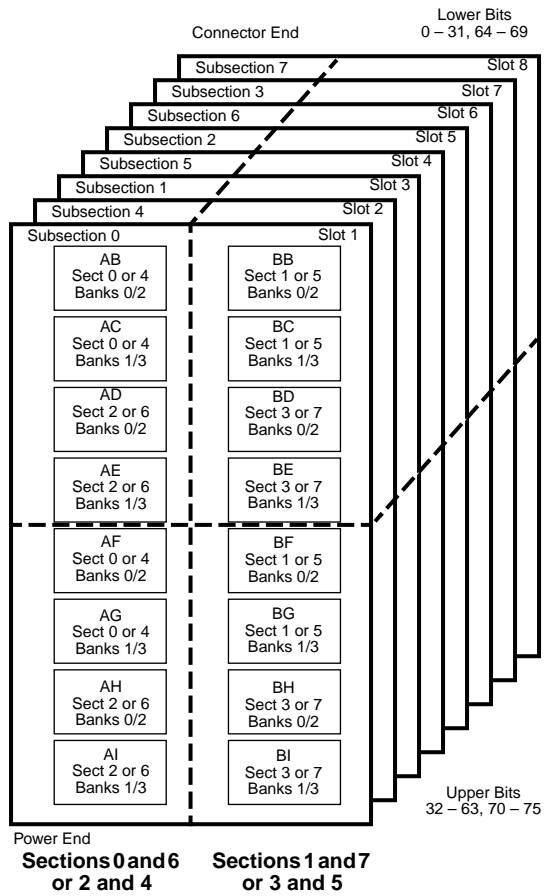

Sections 0 and Section 1
or Sections 4 and Section 5

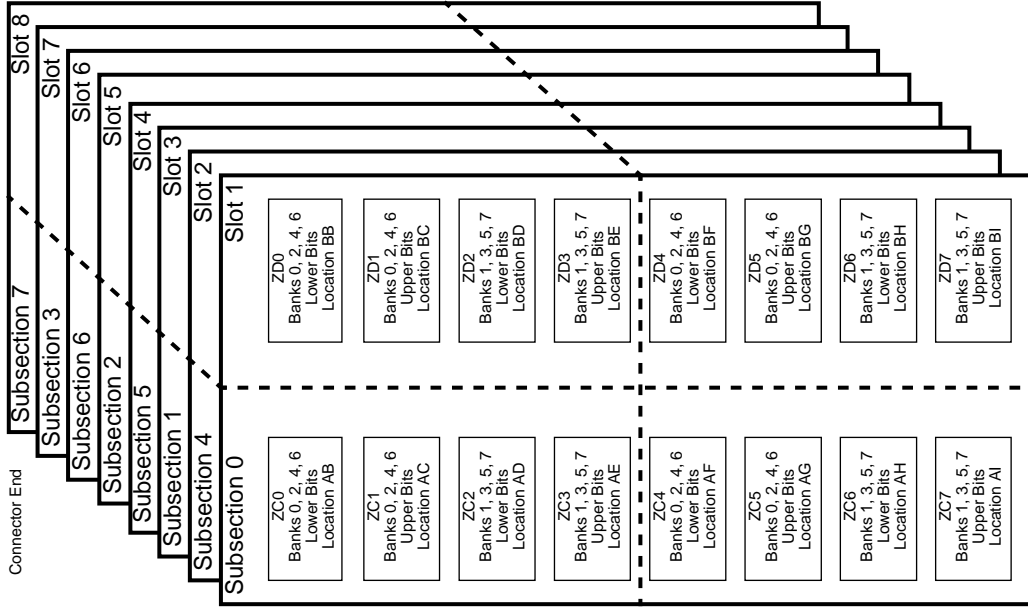

Sections 6 and Section 7
or Sections 2 and Section 3

Power End

CRAY T916 Bank Layout for Asynchronous CM03 Module

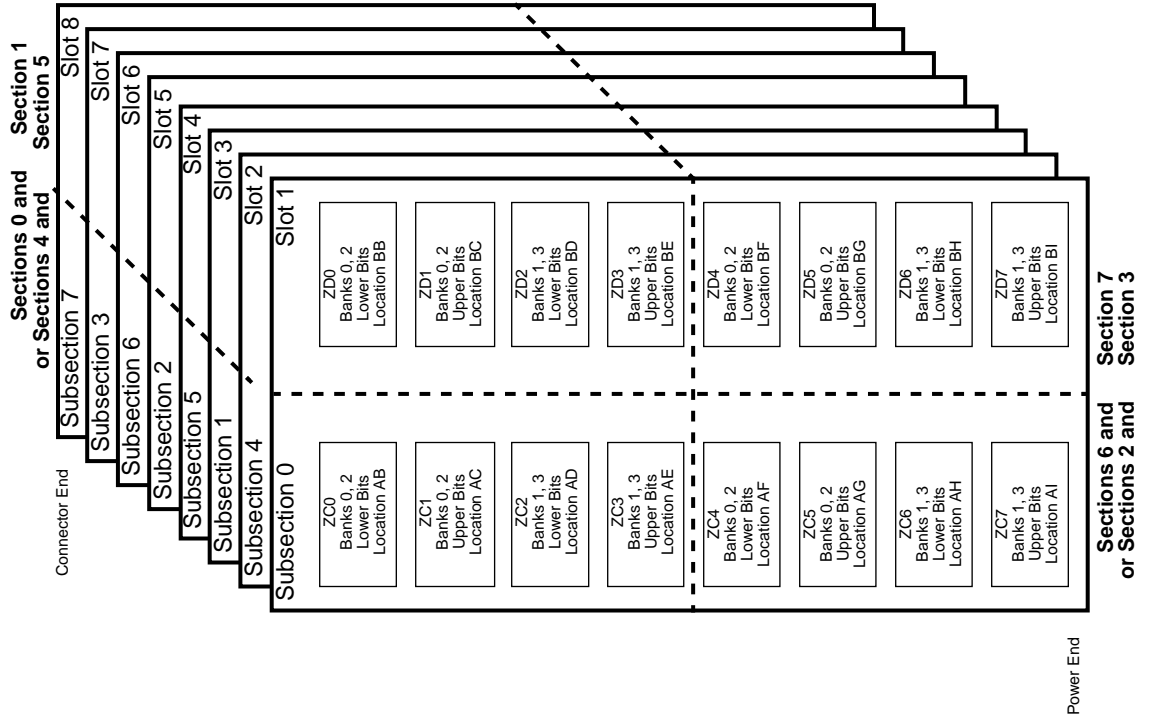

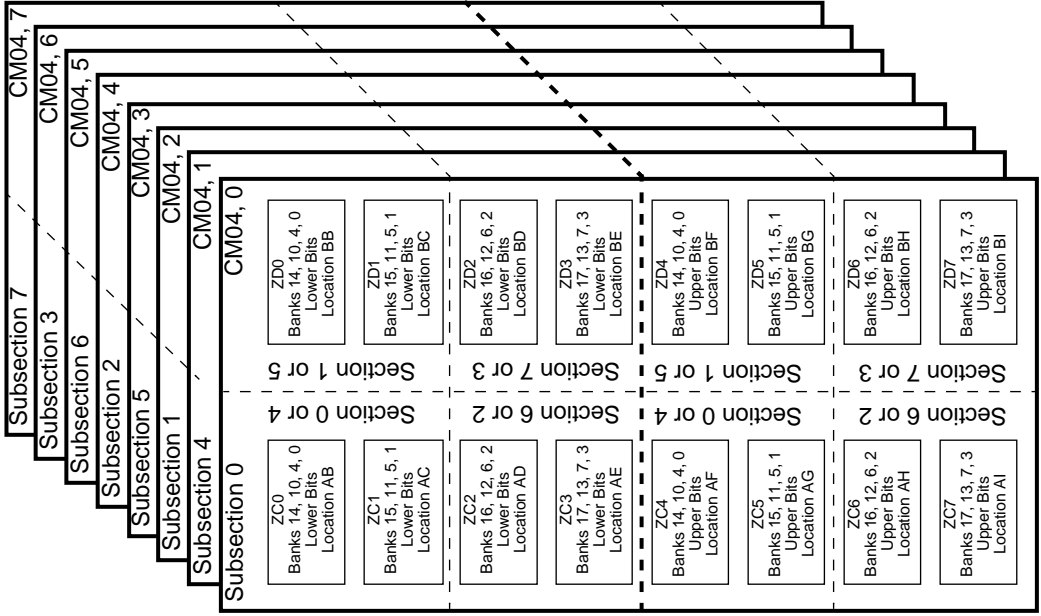

CRAY T916 Memory Address for CM02 Module

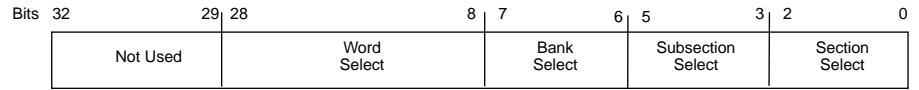

CRAY T916 System Configuration for CM02 Module

Module Counts			Configuration				Address Bits			
Processor	Network	Memory	Sections	Subsections	Banks	Mwords	Section	Subsection	Bank	Word
4 to 8	4	8	8	4	128	256	00, 01, 02	03, 04	05, 06	07 – 31
4 to 8 ^a	4	8	8	2	64	128	00, 01, 02	03	04, 05	06 – 30
4 to 8 ^a	2	8	4	4	64	128	00, 01	02, 03	04, 05	06 – 30
4 to 8 ^a	2	4	4	2	32	64	00, 01	02	03, 04	05 – 29
4 to 8	4	16	8	8	256	512	00, 01, 02	03, 04, 05	06, 07	08 – 32
4 to 8 ^a	4	8	8	4	128	256	00, 01, 02	03, 04	05, 06	07 – 31
4 to 8 ^a	2	8	4	8	128	256	00, 01	02, 03, 04	05, 06	07 – 31
4 to 8 ^a	2	4	4	4	64	128	00, 01	02, 03	04, 05	06 – 30
8 to 16	8	16	8	8	256	512	00, 01, 02	03, 04, 05	06, 07	08 – 32
8 to 16 ^a	8	8	8	4	128	256	00, 01, 02	03, 04	05, 06	07 – 31
8 to 16 ^a	4	8	4	8	128	256	00, 01	02, 03, 04	05, 06	07 – 31

^a This indicates a degraded or partitioned system; the system is not usually sold with this configuration.

CRAY T916 Memory Address for Synchronous CM03 Module

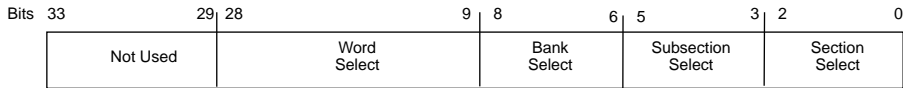

CRAY T916 System Configuration for Synchronous CM03 Module

Module Counts			Configuration				Address Bits			
Processor	Network	Memory	Sections	Subsections	Banks	Mwords	Section	Subsection	Bank	Word
4 to 8	4	8	8	4	256	256	00, 01, 02	03, 04	05, 06, 07	08-32
4 to 8 ^a	4	8	8	2	128	128	00, 01, 02	03	04, 05, 06	07-31
4 to 8 ^a	2	8	4	4	128	128	00, 01	02, 03	04, 05, 06	07-31
4 to 8 ^a	2	4	4	2	64	64	00, 01	02	03, 04, 05	06-30
4 to 8	4	16	8	8	512	512	00, 01, 02	03, 04, 05	06, 07, 08	09-33
4 to 8 ^a	4	8	8	4	256	256	00, 01, 02	03, 04	05, 06, 07	08-32
4 to 8 ^a	2	8	4	8	256	256	00, 01	02, 03, 04	05, 06, 07	08-32
4 to 8 ^a	2	4	4	4	128	128	00, 01	02, 03	04, 05, 06	08-31
8 to 16	8	16	8	8	512	512	00, 01, 02	03, 04, 05	06, 07, 08	09-33
8 to 16 ^a	8	8	8	4	256	256	00, 01, 02	03, 04	05, 06, 07	08-32
8 to 16 ^a	4	8	4	8	256	256	00, 01	02, 03, 04	05, 06, 07	08-32
8 to 16 ^a	4	8	4	4	128	128	00, 01	02, 03	04, 05, 06	07-31

^a This indicates a degraded or partitioned system; the system is not usually sold with this configuration.

CRAY T916 Memory Address for Asynchronous CM03 Module

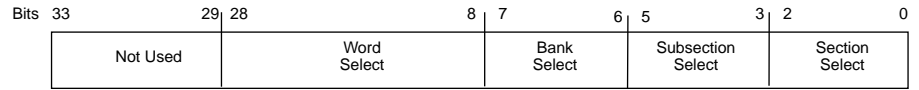

CRAY T916 System Configuration for Asynchronous CM03 Module

Module Counts			Configuration				Address Bits			
Processor	Network	Memory	Sections	Subsections	Banks	Mwords	Section	Subsection	Bank	Word
4 to 8	4	8	8	4	128	256	00, 01, 02	03, 04	05, 06	07–32
4 to 8 ^a	4	8	8	2	64	128	00, 01, 02	03	04, 05	06–31
4 to 8 ^a	2	8	4	4	64	128	00, 01	02, 03	04, 05	06–31
4 to 8 ^a	2	4	4	2	32	64	00, 01	02	03, 04	05–30
4 to 8	4	16	8	8	256	512	00, 01, 02	03, 04, 05	06, 07	08–33
4 to 8 ^a	4	8	8	4	128	256	00, 01, 02	03, 04	05, 06	07–32
4 to 8 ^a	2	8	4	8	128	256	00, 01	02, 03, 04	05, 06	07–32
4 to 8 ^a	2	4	4	4	64	128	00, 01	02, 03	04, 05	06–31
8 to 16	8	16	8	8	256	512	00, 01, 02	03, 04, 05	06, 07	08–33
8 to 16 ^a	8	8	8	4	128	256	00, 01, 02	03, 04	05, 06	07–32
8 to 16 ^a	4	8	4	8	128	256	00, 01	02, 03, 04	05, 06	07–32
8 to 16 ^a	4	8	4	4	64	128	00, 01	02, 03	04, 05	06–31

^a This indicates a degraded or partitioned system; the system is not usually sold with this configuration.

CRAY T916 Memory Address for CM04 Module

Bits 33	30	29	9	8	6	5	3	2	0
Not Used		Word Select			Bank Select		Subsection Select		Section Select

CRAY T916 System Configuration for CM04 Module

Module Counts			Configuration				Address Bits			
Processor	Network	Memory	Sections	Subsections	Banks	Mwords	Section	Subsection	Bank	Word
4 to 8	4	8	8	4	256	512	00, 01, 02	03, 04	05, 06, 07	08-32
4 to 8 ^a	4	8	8	2	128	256	00, 01, 02	03	04, 05, 06	07-31
4 to 8 ^a	2	8	4	4	128	256	00, 01	02, 03	04, 05, 06	07-31
4 to 8 ^a	2	4	4	2	64	128	00, 01	02	03, 04, 05	06-30
4 to 8	4	16	8	8	512	1,024	00, 01, 02	03, 04, 05	06, 07, 08	09-33
4 to 8 ^a	4	8	8	4	256	512	00, 01, 02	03, 04	05, 06, 07	08-32
4 to 8 ^a	2	8	4	8	256	512	00, 01	02, 03, 04	05, 06, 07	08-32
4 to 8 ^a	2	4	4	4	128	256	00, 01	02, 03	04, 05, 06	07-31
8 to 16	8	16	8	8	512	1,024	00, 01, 02	03, 04, 05	06, 07, 08	09-33
8 to 16 ^a	8	8	8	4	256	512	00, 01, 02	03, 04	05, 06, 07	08-32
8 to 16 ^a	4	8	4	8	256	512	00, 01	02, 03, 04	05, 06, 07	08-32
8 to 16 ^a	4	8	4	4	128	256	00, 01	02, 03	04, 05, 06	07-31

^a This indicates a degraded or partitioned system; the system is not usually sold with this configuration.

CRAY T932 Memory Chassis Map

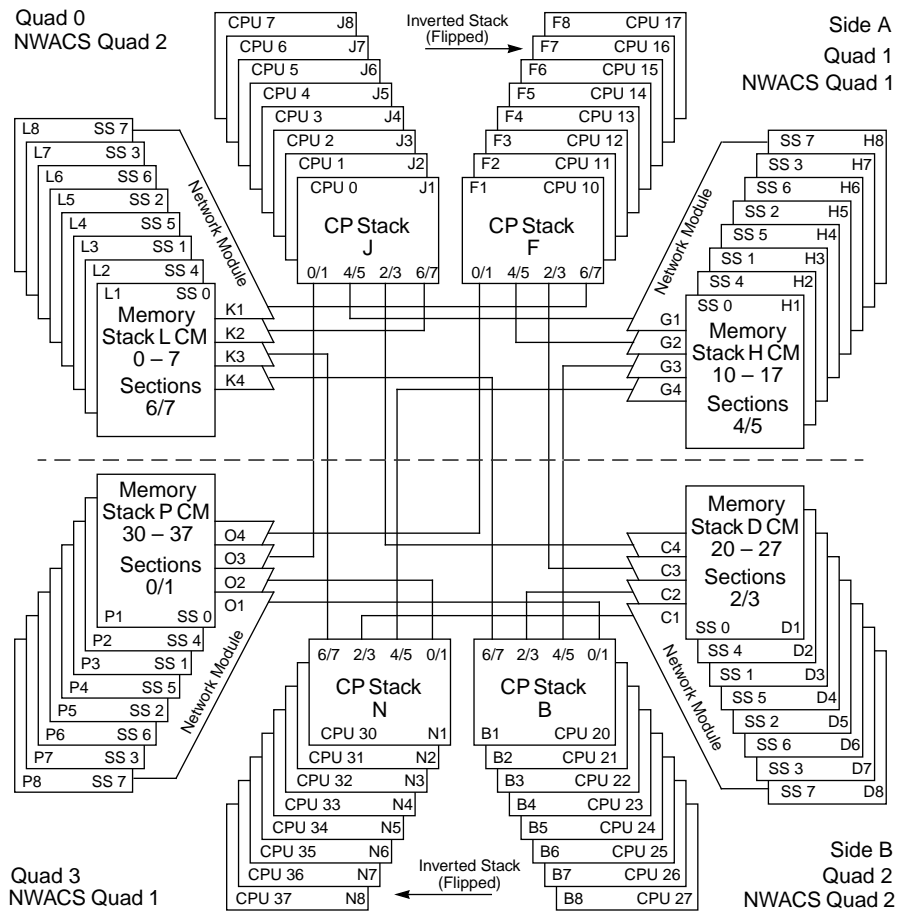

CRAY T932 Bank Layout for CM02 Module

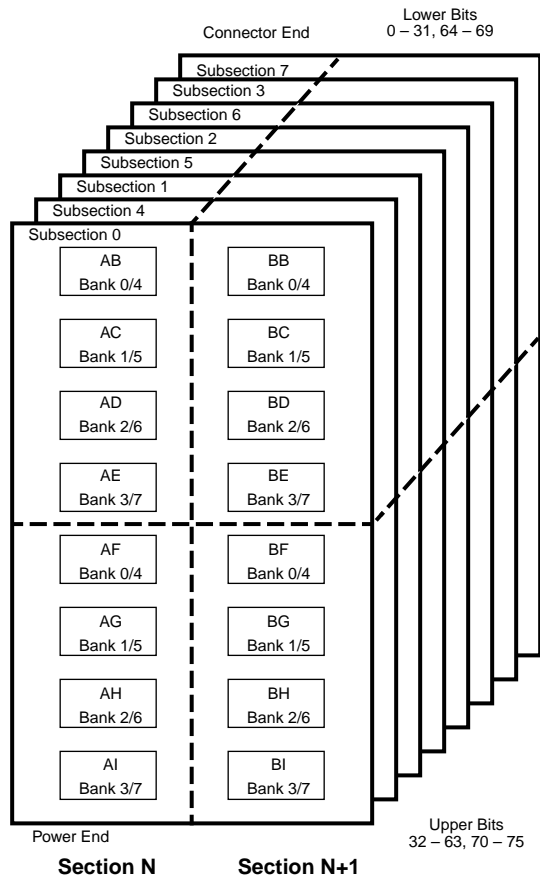

CRAY T932 Bank Layout for Synchronous CM03 Module

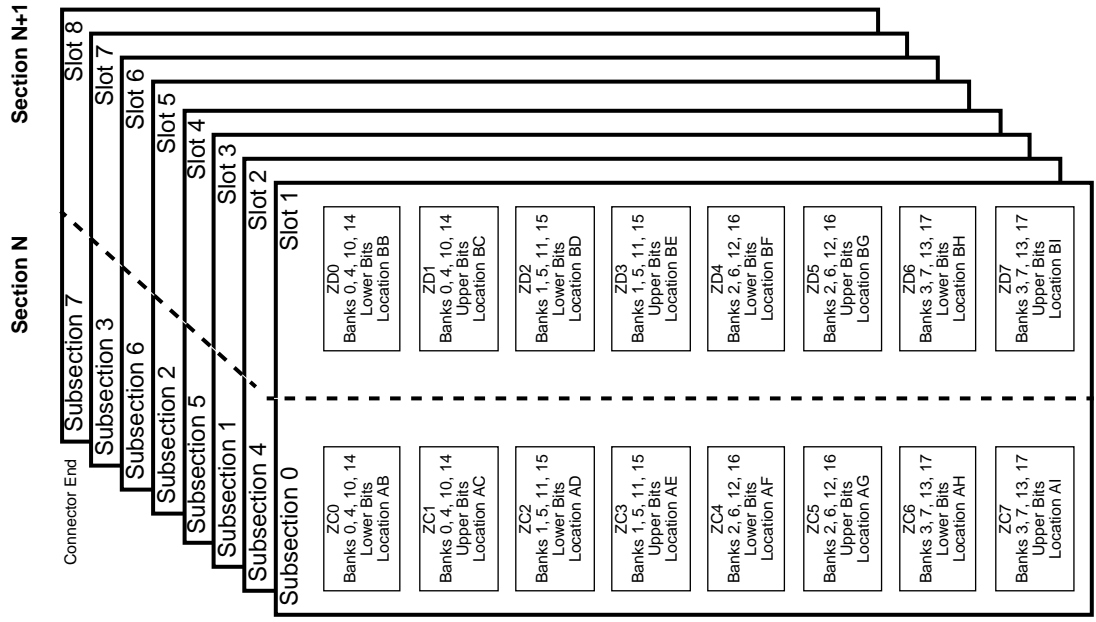

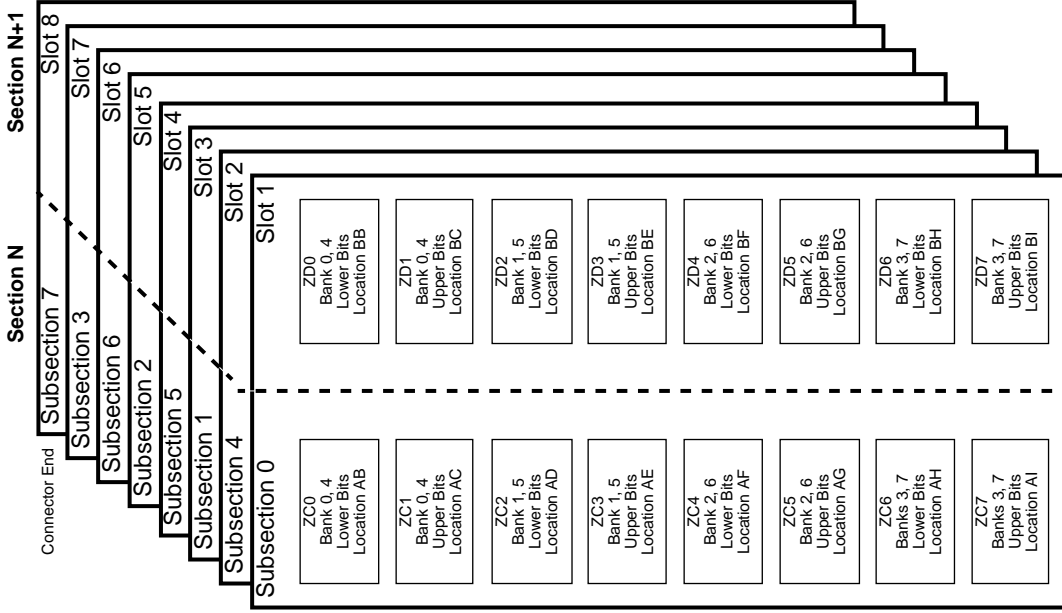

Power End

CRAY T932 Bank Layout for CM04 Module

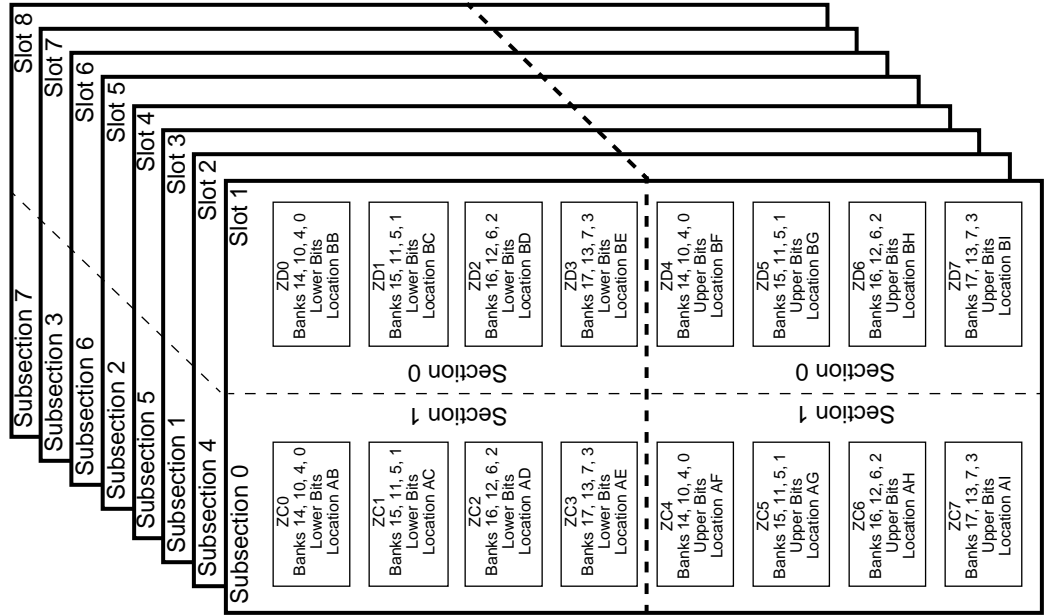

CRAY T932 Memory Address for CM02 Module

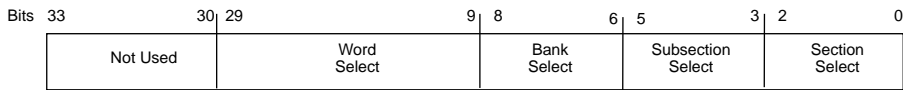

CRAY T932 System Configuration for CM02 Module

Module Counts			Configuration				Address Bits			
Processor	Network	Memory	Sections	Subsections	Banks	Mwords	Section	Subsection	Bank	Word
8	4	32	8	8	512	1,024	00, 01, 02	03, 04, 05	06, 07, 08	09-33
8	4	16	8	4	256	512	00, 01, 02	03, 04	05, 06, 07	08-32
8 ^a	4	8	8	2	128	256	00, 01, 02	03	04, 05, 06	07-31
8	8	8	8	2	128	256	00, 01, 02	03	04, 05, 06	07-31
8 ^a	8	8	8	2	64	128	00, 01, 02	03	04, 05	06-30
8 ^a	4	4	4	2	64	128	00, 01	02	03, 04, 05	06-30
8 ^a	4	4	4	2	32	64	00, 01	02	03, 04	05-29
8 to 16	8	16	8	4	256	512	00, 01, 02	03, 04	05, 06, 07	08-32
8 to 16 ^a	8	16	8	4	128	256	00, 01, 02	03, 04	05, 06	07-31
8 to 16 ^a	8	8	8	2	128	256	00, 01, 02	03	04, 05, 06	07-31
8 to 16 ^a	4	8	4	4	128	256	00, 01	02, 03	04, 05, 06	07-31
16	16	16	8	4	256	512	00, 01, 02	03, 04	05, 06, 07	08-32
16 ^a	16	16	8	4	128	256	00, 01, 02	03, 04	05, 06	07-31
16 ^a	16	8	8	2	128	256	00, 01, 02	03	04, 05, 06	07-31
16 ^a	8	8	4	4	128	256	00, 01	02, 03	04, 05, 06	07-31
16 to 32	16	32	8	8	512	1,024	00, 01, 02	03, 04, 05	06, 07, 08	09-33
16 to 32 ^a	16	32	8	8	256	512	00, 01, 02	03, 04, 05	06, 07	08-32
16 to 32 ^a	16	16	8	4	256	512	00, 01, 02	03, 04	05, 06, 07	08-32
16 to 32 ^a	8	16	4	8	256	512	00, 01	02, 03, 04	05, 06, 07	08-32

^a This indicates a degraded or partitioned system; the system is not usually sold with this configuration.

CRAY T932 Memory Address for Synchronous CM03 Module

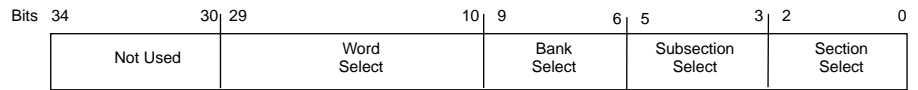

CRAY T932 System Configuration for Synchronous CM03 Module

Module Counts			Configuration				Address Bits			
Processor	Network	Memory	Sections	Subsections	Banks	Mwords	Section	Subsection	Bank	Word
8	4	32	8	8	1,024	1,024	00, 01, 02	03, 04, 05	06, 07, 08, 09	10 – 34
8	4	16	8	4	512	512	00, 01, 02	03, 04	05, 06, 07, 08	09 – 33
8 ^a	4	8	8	2	256	256	00, 01, 02	03	04, 05, 06, 07	08 – 32
8	8	8	8	2	256	256	00, 01, 02	03	04, 05, 06, 07	08 – 32
8 ^a	8	8	8	2	128	128	00, 01, 02	03	04, 05, 06	07 – 31
8 ^a	4	4	4	2	128	128	00, 01	02	03, 04, 05, 06	07 – 31
8 ^a	4	4	4	2	64	64	00, 01	02	03, 04, 05	06 – 30
8 to 16	8	16	8	4	512	512	00, 01, 02	03, 04	05, 06, 07, 08	09 – 33
8 to 16 ^a	8	16	8	4	256	256	00, 01, 02	03, 04	05, 06, 07	08 – 32
8 to 16 ^a	8	8	8	2	256	256	00, 01, 02	03	04, 05, 06, 07	08 – 32
8 to 16 ^a	4	8	4	4	256	256	00, 01	02, 03	04, 05, 06, 07	08 – 32
16	16	16	8	4	512	512	00, 01, 02	03, 04	05, 06, 07, 08	09 – 33
16 ^a	16	16	8	4	256	256	00, 01, 02	03, 04	05, 06, 07	08 – 32
16 ^a	16	8	8	2	256	256	00, 01, 02	03	04, 05, 06, 07	08 – 32
16 ^a	8	8	4	4	256	256	00, 01	02, 03	04, 05, 06, 07	08 – 32
16 to 32	16	32	8	8	1,024	1,024	00, 01, 02	03, 04, 05	06, 07, 08, 09	10 – 34
16 to 32 ^a	16	32	8	8	512	512	00, 01, 02	03, 04, 05	06, 07, 08	09 – 33
16 to 32 ^a	16	16	8	4	512	512	00, 01, 02	03, 04	05, 06, 07, 08	09 – 33
16 to 32 ^a	8	16	4	8	512	512	00, 01	02, 03, 04	05, 06, 07, 08	09 – 33

^a This indicates a degraded or partitioned system; the system is not usually sold with this configuration.

CRAY T932 Memory Address for CM04 Module

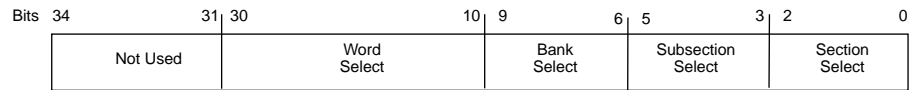

CRAY T932 System Configuration for CM04 Module

Module Counts			Configuration				Address Bits			
Processor	Network	Memory	Sections	Subsections	Banks	Mwords	Section	Subsection	Bank	Word
8	4	32	8	8	1,024	2,048	00, 01, 02	03, 04, 05	06, 07, 08, 09	10 – 34
8	4	16	8	4	512	1,024	00, 01, 02	03, 04	05, 06, 07, 08	09 – 33
8 ^a	4	8	8	2	256	512	00, 01, 02	03	04, 05, 06, 07	08 – 32
8	8	8	8	2	256	512	00, 01, 02	03	04, 05, 06, 07	08 – 32
8 ^a	8	8	8	2	128	256	00, 01, 02	03	04, 05, 06	07 – 31
8 ^a	4	4	4	2	128	256	00, 01	02	03, 04, 05, 06	07 – 31
8 ^a	4	4	4	2	64	128	00, 01	02	03, 04, 05	06 – 30
8 to 16	8	16	8	4	512	1,024	00, 01, 02	03, 04	05, 06, 07, 08	09 – 33
8 to 16 ^a	8	16	8	4	256	512	00, 01, 02	03, 04	05, 06, 07	08 – 32
8 to 16 ^a	8	8	8	2	256	512	00, 01, 02	03	04, 05, 06, 07	08 – 32
8 to 16 ^a	4	8	4	4	256	512	00, 01	02, 03	04, 05, 06, 07	08 – 32
16	16	16	8	4	512	1,024	00, 01, 02	03, 04	05, 06, 07, 08	09 – 33
16 ^a	16	16	8	4	256	512	00, 01, 02	03, 04	05, 06, 07	08 – 32
16 ^a	16	8	8	2	256	512	00, 01, 02	03	04, 05, 06, 07	08 – 32
16 ^a	8	8	4	4	256	512	00, 01	02, 03	04, 05, 06, 07	08 – 32
16 to 32	16	32	8	8	1,024	2,048	00, 01, 02	03, 04, 05	06, 07, 08, 09	10 – 34
16 to 32 ^a	16	32	8	8	512	1,024	00, 01, 02	03, 04, 05	06, 07, 08	09 – 33
16 to 32 ^a	16	16	8	4	512	1,024	00, 01, 02	03, 04	05, 06, 07, 08	09 – 33
16 to 32 ^a	8	16	4	8	512	1,024	00, 01	02, 03, 04	05, 06, 07, 08	09 – 33

^a This indicates a degraded or partitioned system; the system is not usually sold with this configuration.

Bit Layout for CM02 Module

	Bank 4, 5, 6, or 7		Bank 0, 1, 2, or 3		
Chip	D0/Q0	D1/Q1	D0/Q0	D1/Q1	Chip
BA	0 (32)	16 (48)	0 (32)	16 (48)	AA
BB	1 (33)	17 (49)	1 (33)	17 (49)	AB
BC	2 (34)	18 (50)	2 (34)	18 (50)	AC
BD	3 (35)	19 (51)	3 (35)	19 (51)	AD
BE	4 (36)	20 (52)	4 (36)	20 (52)	AE
BF	5 (37)	21 (53)	5 (37)	21 (53)	AF
BG	6 (38)	22 (54)	6 (38)	22 (54)	AG
BH	7 (39)	23 (55)	7 (39)	23 (55)	AH
BI	8 (40)	24 (56)	8 (40)	24 (56)	AI
BJ	9 (41)	25 (57)	9 (41)	25 (57)	AJ
BK	10 (42)	26 (58)	10 (42)	26 (58)	AK
BL	11 (43)	27 (59)	11 (43)	27 (59)	AL
BM	12 (44)	28 (60)	12 (44)	28 (60)	AM
BN	13 (45)	29 (61)	13 (45)	29 (61)	AN
BO	14 (46)	30 (62)	14 (46)	30 (62)	AO
BP	15 (47)	31 (63)	15 (47)	31 (63)	AP
BQ	64 (70)	67 (73)	64 (70)	67 (73)	AQ
BR	65 (71)	68 (74)	65 (71)	68 (74)	AR
BS	66 (72)	69 (75)	66 (72)	69 (75)	AS

Bit Layout for Synchronous CM03 Memory Module

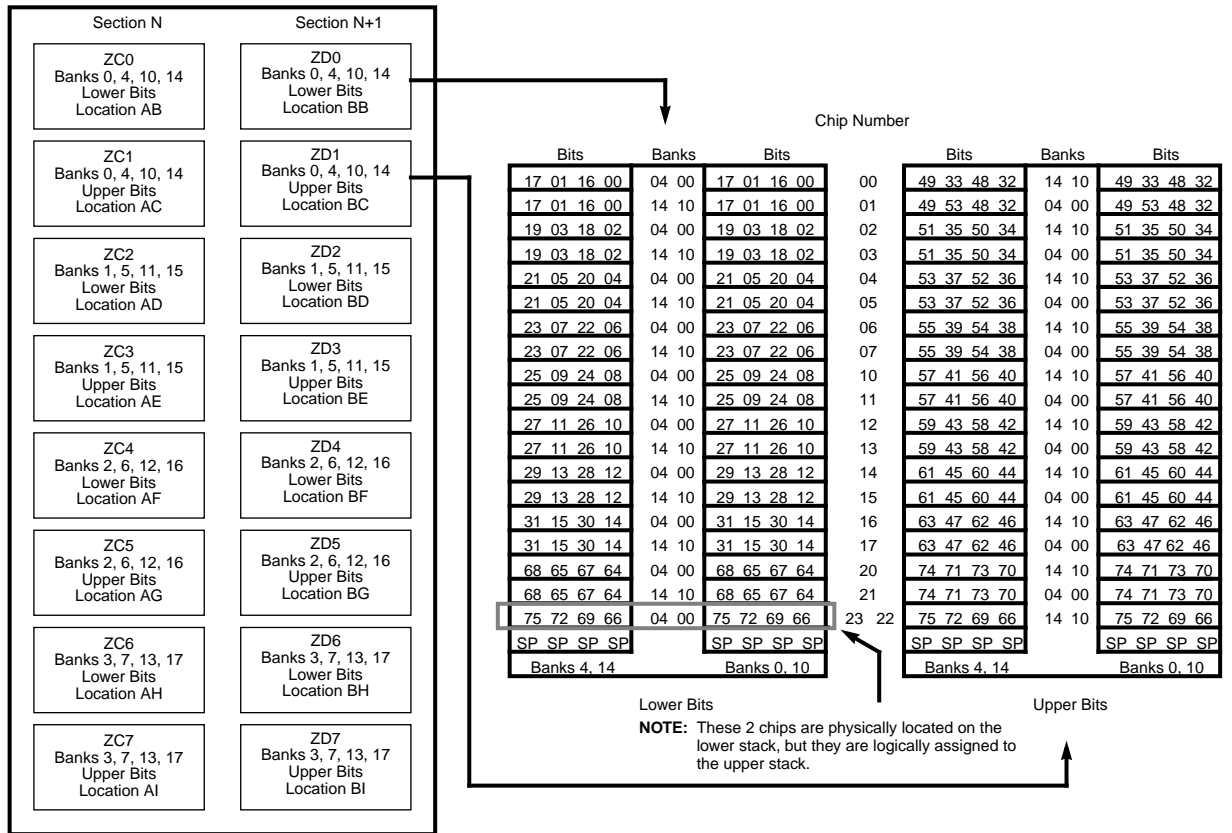

Bit Layout for Asynchronous CM03 Memory Module

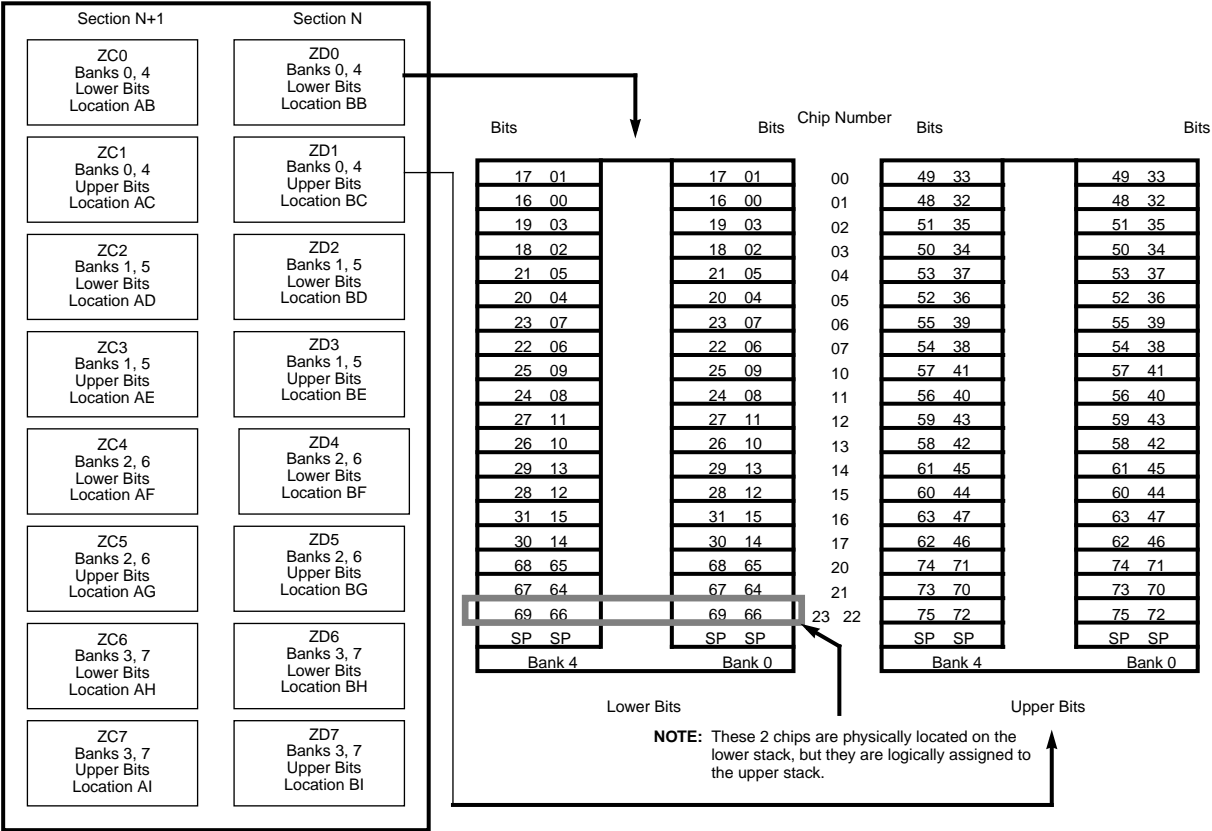

Bit Layout for CM04 Memory Module

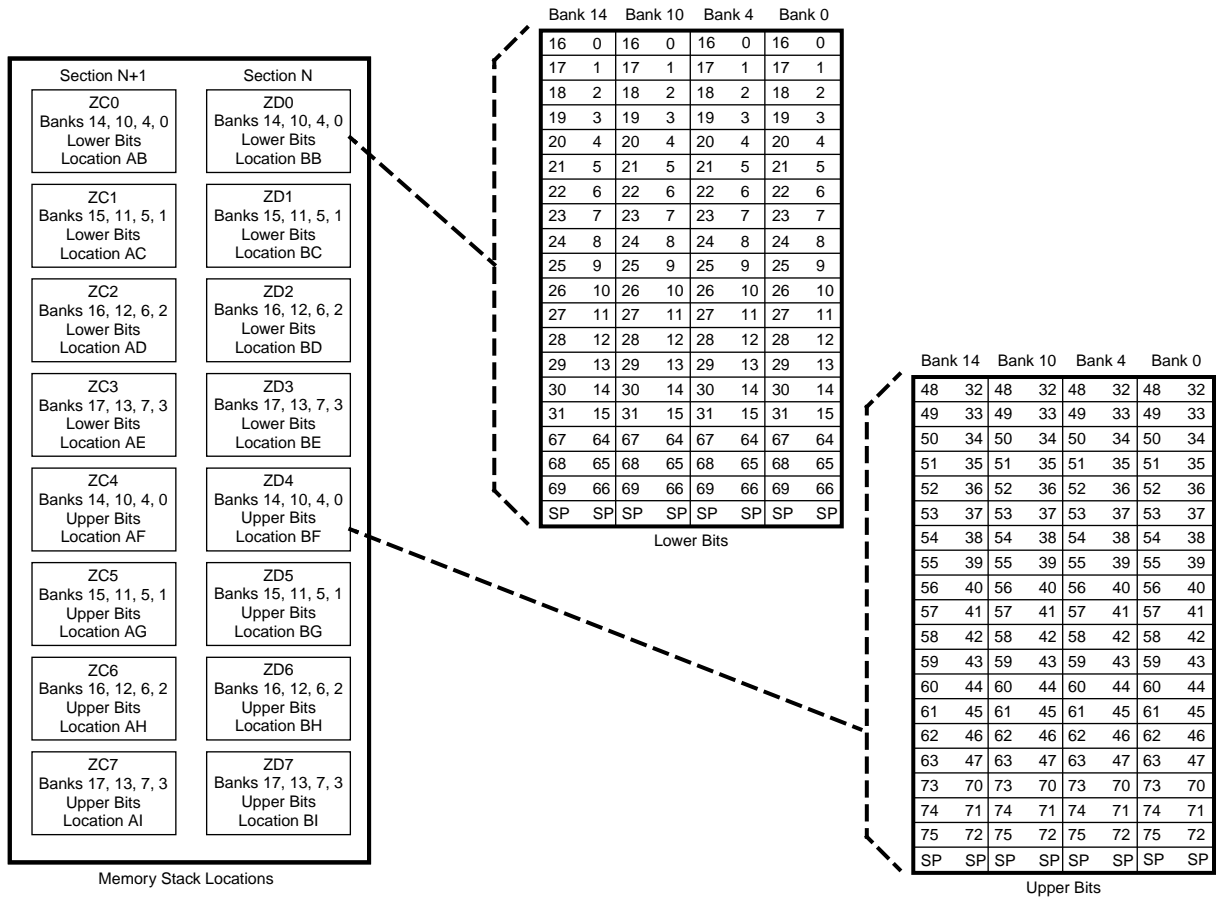

Connectors

SIB Connector Layout

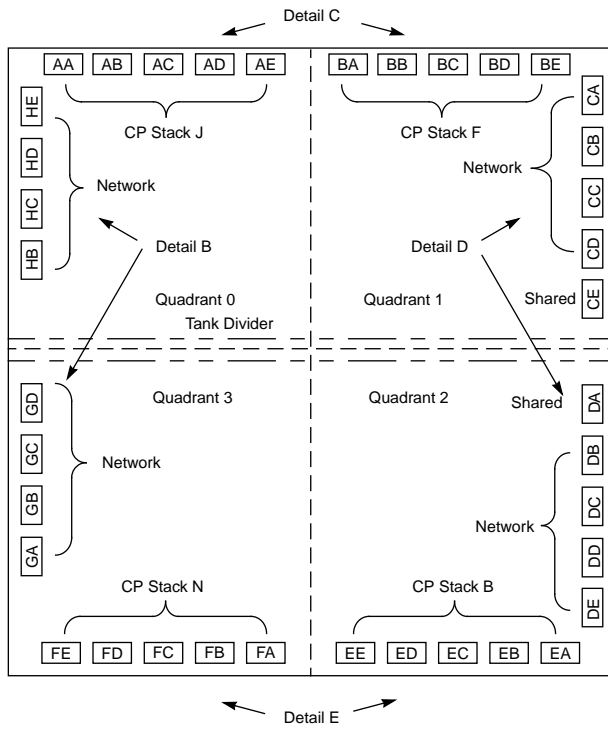

SIB EZIF Connector Numbering Sequence (Detail B)

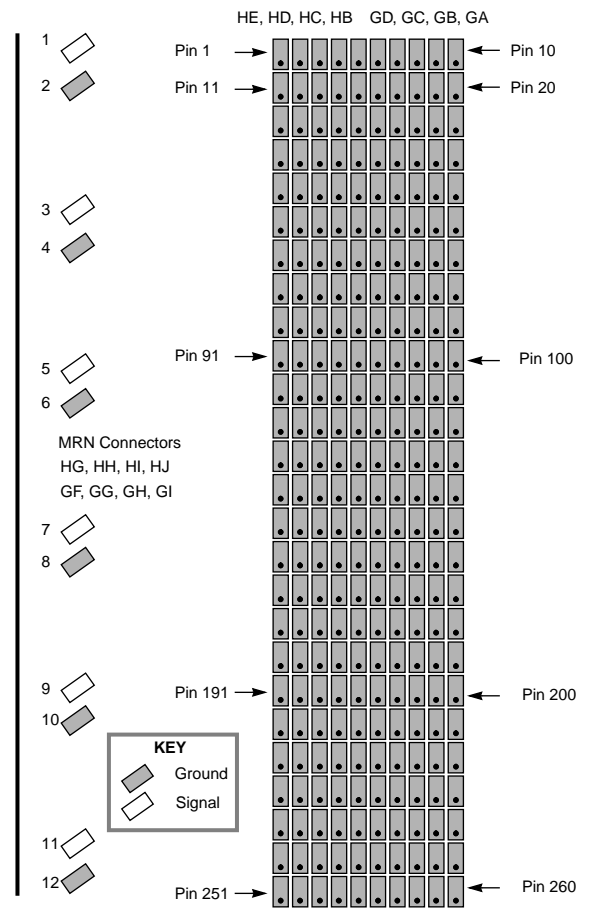

SIB EZIF Connector Numbering Sequence (Detail D)

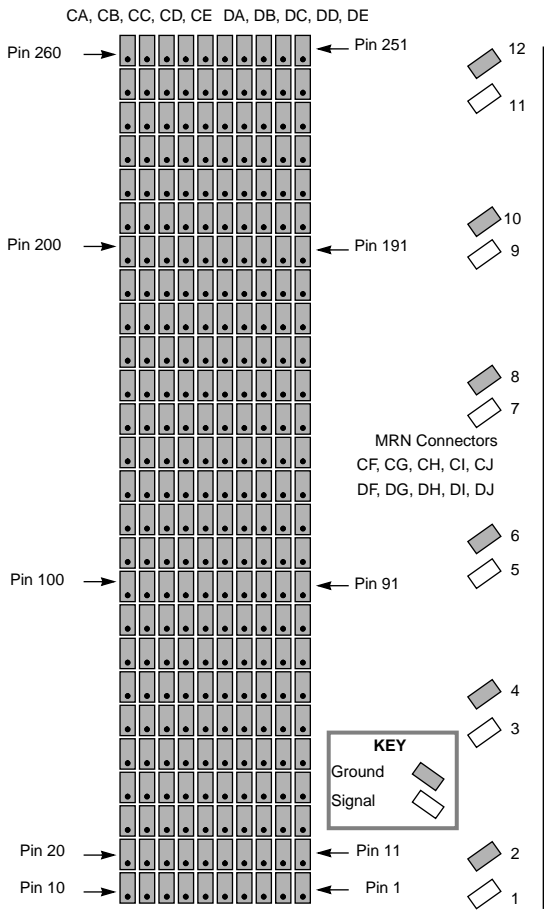

SIB EZIF Connector Numbering Sequence (Detail C)

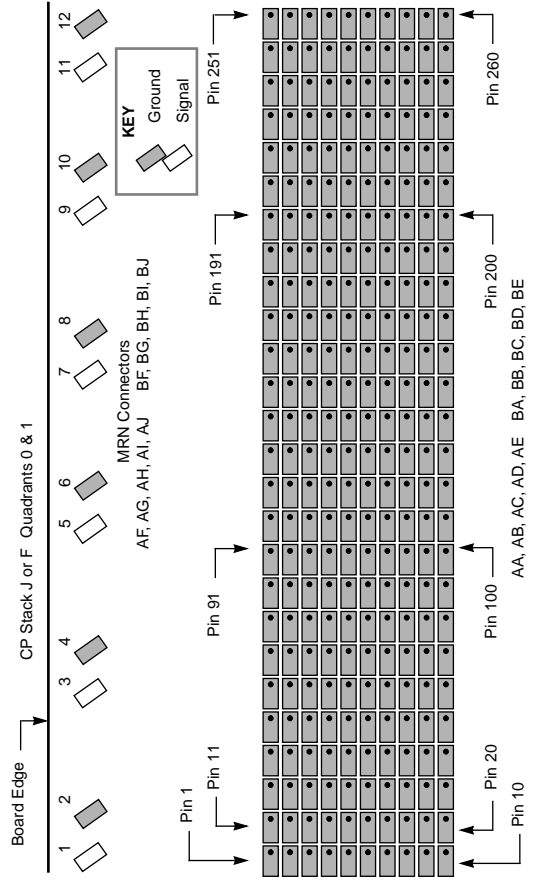

SIB EZIF Connector Numbering Sequence (Detail E)

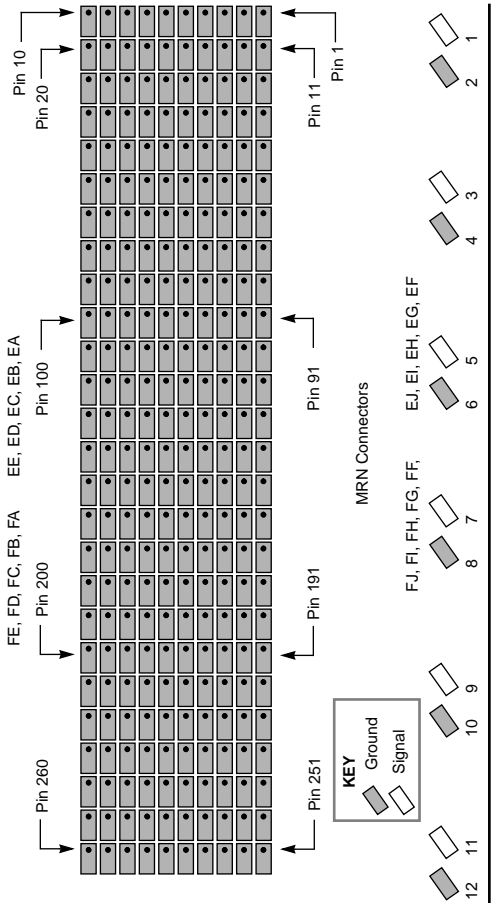

Edge Connector for CM02/03 Viewed from Layer 1

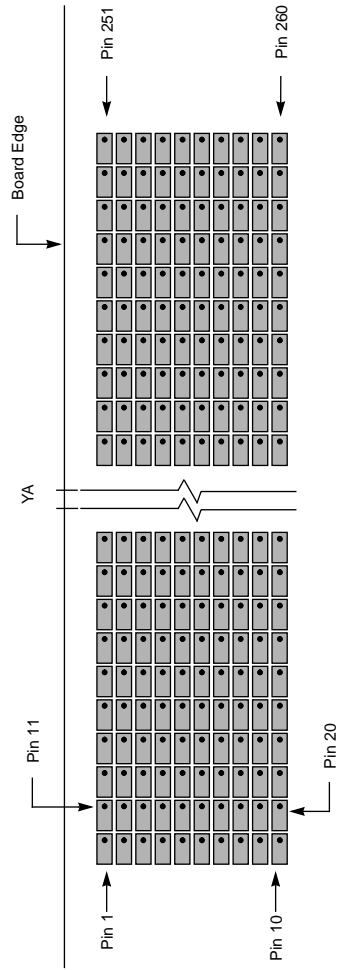

Maintenance Connector for CM02/03

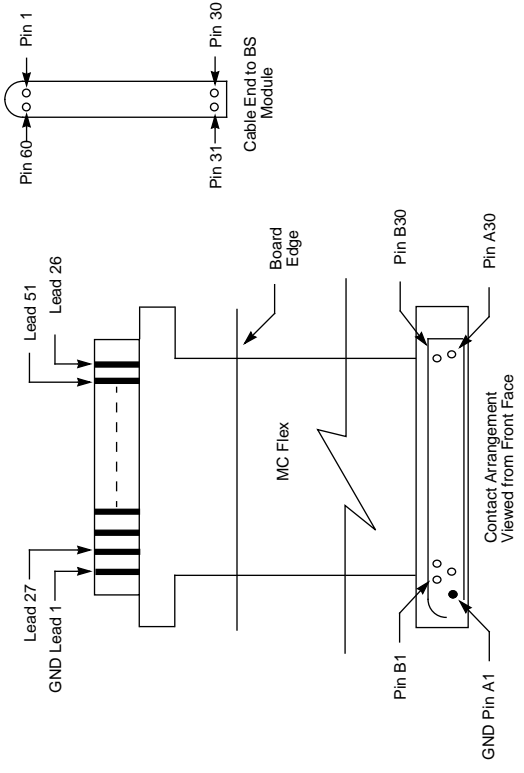

MSC Flex Connector for CM02 Viewed from Layer 1

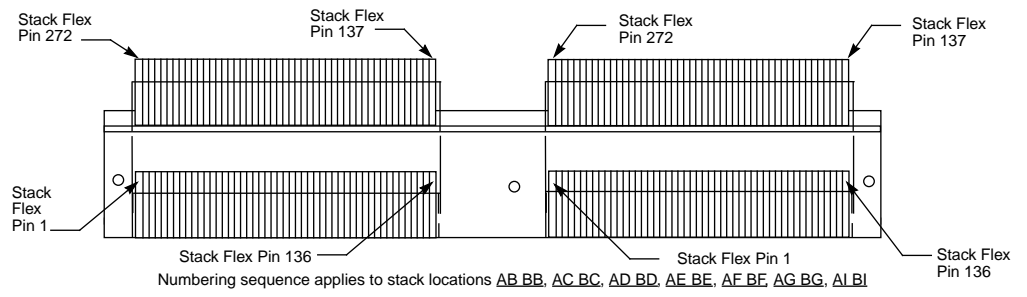

MSC Flex Connector for CM03 Viewed from Layer 1

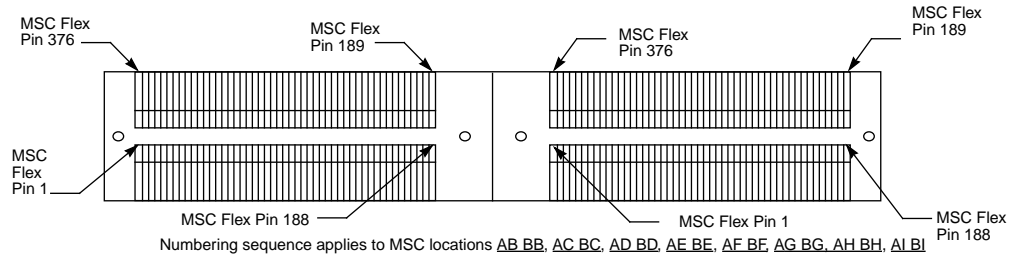

MSC Flex Connector for CM04 Viewed from Layer 1

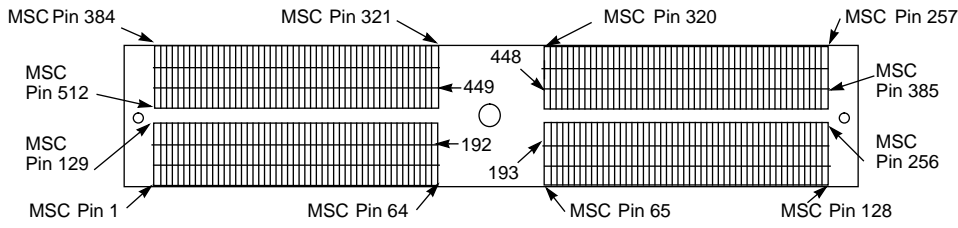

Chip Pinouts

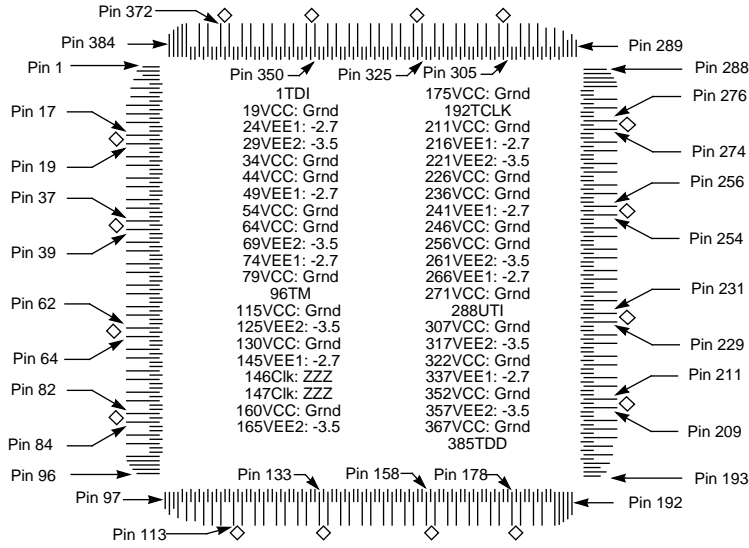

Cable Bulkhead for CRAY T94 System (IO01 Module)

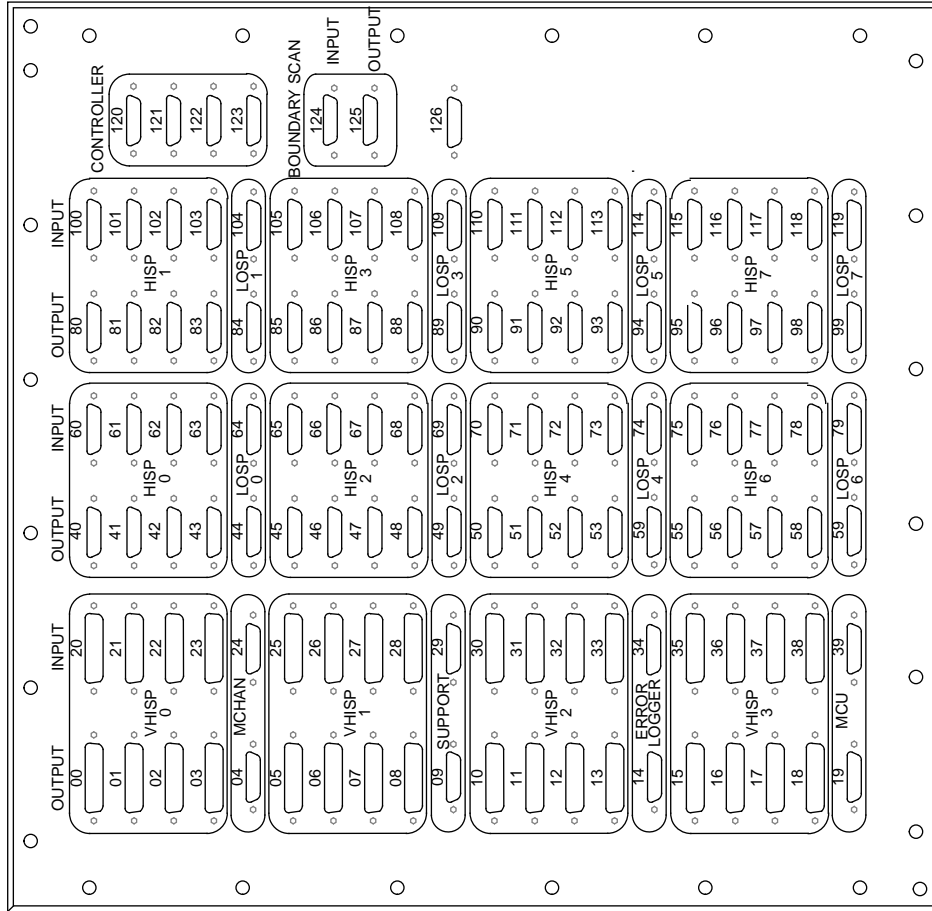

Cable Bulkhead for CRAY T94 System (IO02 Module)

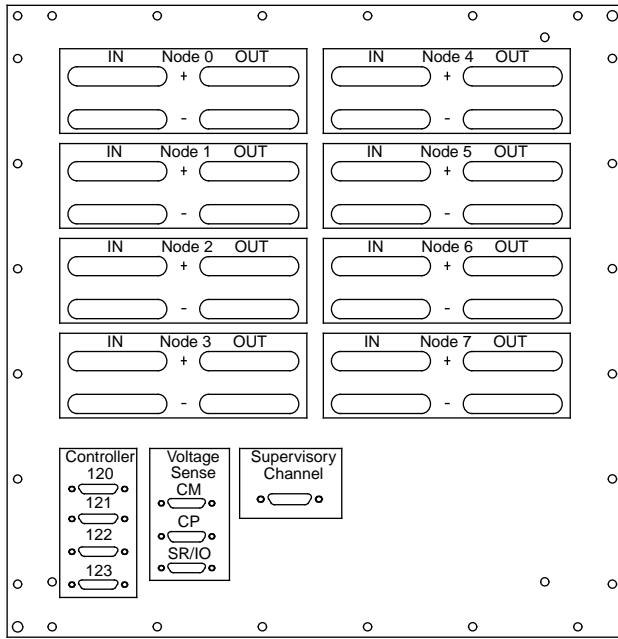

See next page for node assignments.

Node/Quad Assignments for IO2 Module (Upright)

Bulkhead Channel Designator	IO Module Quad Designator
Node 0	Quad 0 Node A
Node 1	Quad 0 Node B
Node 2	Quad 1 Node A
Node 3	Quad 1 Node B
Node 4	Quad 2 Node A
Node 5	Quad 2 Node B
Node 6	Quad 3 Node A
Node 7	Quad 3 Node B

Node/Quad Assignments for IO2 Module (Inverted) at Chassis Locations E1, M1

Bulkhead Channel Designator	IO Module Quad Designator
Node 0	Quad 3 Node A
Node 1	Quad 3 Node B
Node 2	Quad 2 Node A
Node 3	Quad 2 Node B
Node 4	Quad 1 Node A
Node 5	Quad 1 Node B
Node 6	Quad 0 Node A
Node 7	Quad 0 Node B

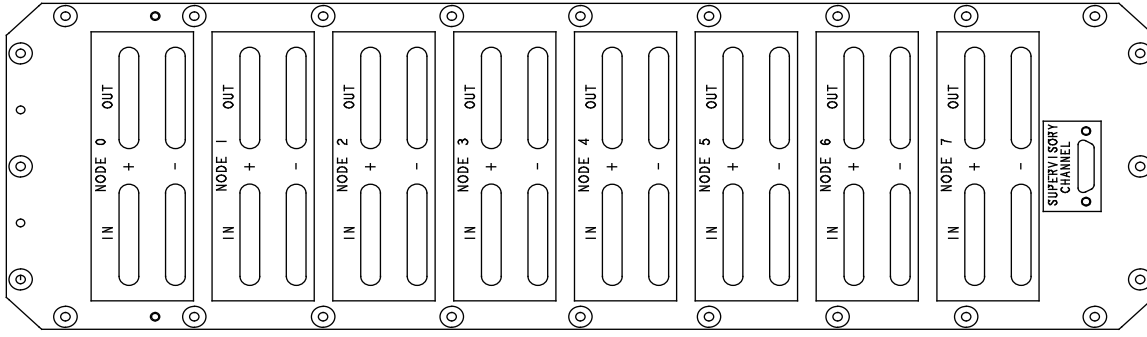

See previous page for node assignments.

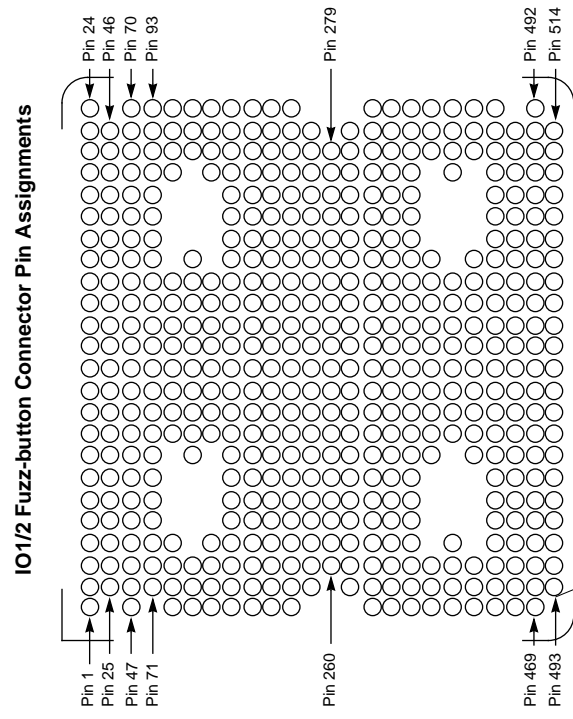

I/O Channel Assignments (CRAY T94 System)

IO Module	CPU Physical Number	Shared Rel. CPU Number	IO Module Quadrant	V/HISP Number	LOSP Number	HISP Number	Support Channel Number
A	0	0	0	20	100/101,102/103	400, 401	60/61
	1	1	1	21	104/105,106/107	402, 403	
	2	2	2	22	110/111,112/113	404, 405	
	3	3	3	23	114/115,116/117	406, 407	

I/O Channel Assignments (CRAY T916 System)

IO Module	CPU Physical Number	Shared Rel. CPU Number	IO Module Quadrant	VHISP Number	LOSP Number	HISP Number	Support Channel Number
1	2	2	0	20	100/101,102/103	400, 401	60/61
	3	3	1	21	104/105,106/107	402, 403	
	4	4	2	22	110/111,112/113	404, 405	
	5	5	3	23	114/115,116/117	406, 407	
E	12	12	3	24	120/121,122/123	410, 411	60/61
	13	13	2	25	124/125,126/127	412, 413	
	14	14	1	26	130/131,132/133	414, 415	
	15	15	0	27	134/135,136/137	416, 417	

I/O Channel Assignments (CRAY T932 System)

IO Module	CPU Physical Number	IO Module Quadrant	VHISP Number	LOSP Number	HISP Number	Support Channel Number
A	22	0	30	140/141,142/143	420, 421	64/65
	23	1	31	144/145,146/147	422, 423	
	24	2	32	150/151,152/153	424, 425	
	25	3	33	154/155,156/157	426, 427	
E	12	3	24	120/121,122/123	410, 411	62/63
	13	2	25	124/125,126/127	412, 413	
	14	1	26	130/131,132/133	414, 415	
	15	0	27	134/135,136/137	416, 417	
I	2	0	20	100/101,102/103	400, 401	60/61
	3	1	21	104/105,106/107	402, 403	
	4	2	22	110/111,112/113	404, 405	
	5	3	23	114/115,116/117	406, 407	
M	32	3	34	160/161,162/163	430, 431	66/67
	33	2	35	164/165,166/167	432, 433	
	34	1	36	170/171,172/173	434, 435	
	35	0	37	174/175,176/177	436, 437	

Boundary Scan Connector Layout

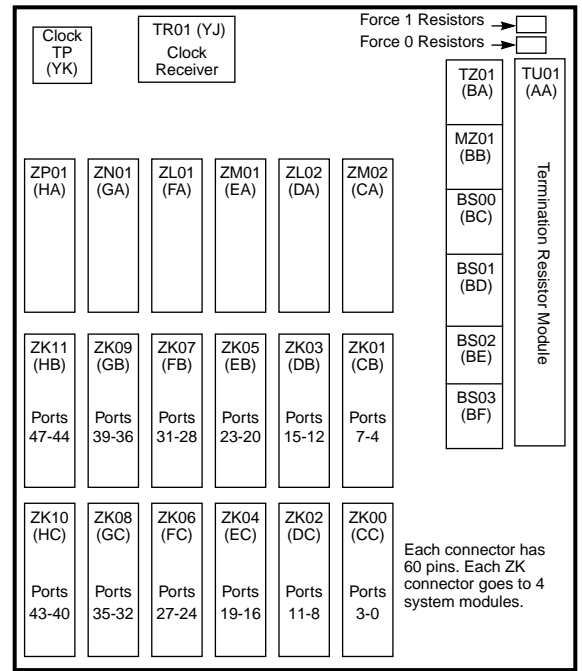

Boundary Scan Module Connectors for CRAY T94 System

Connector Location	Port Numbers	Destination
CB	7 - 4	C1, A1
EB	23 - 20	C5, C4, C3, C2
FA, EA	--	Maintenance Channel from bulkhead
GA	--	Control System
GB	39 - 36	B1, B2, B3, B4
HA	--	Maintenance Connector
DA, CA	--	Passon Channel from IO module

**Boundary Scan Module Connectors for CRAY T916 and
CRAY T932 Systems (Quadrants 0 and 1)**

Connector Location	Port Numbers	Module Destination		External Destination
		Stack	Number	
HA	--	--	--	Maintenance Connector
HB	47 - 44	H	1 - 4	--
HC	43 - 40	L	1 - 4	--
GA	--	--	--	Control System
GB	39 - 36	H	5 - 8	--
GC	35 - 32	L	5 - 8	--
FA, EA	--	--	--	Maintenance Channel from bulkhead
FB	31 - 28	G5, E, I		--
FC	27 - 24	Spare		--
EB	23 - 20	G	1 - 4	--
EC	19 - 16	K	1 - 4	--
DB	15 - 12	F	1 - 4	--
DC	11 - 8	J	1 - 4	--
CB	7 - 4	F	5 - 8	--
CC	3 - 0	J	5 - 8	--
DA, CA	--	--	--	Passon Channel from IO module

**Boundary Scan Module Connectors for
CRAY T932 System (Quadrants 2 and 3)**

Connector Location	Port Number	Module Destination		External Destination
		Stack	Number	
HA	--	--	--	Maintenance Connector
HB	47 - 44	P	1 - 4	--
HC	43 - 40	D	1 - 4	--
GA	--	--	--	Control System
GB	39 - 36	P	5 - 8	--
GC	35 - 32	D	5 - 8	
FA, EA	--	--	--	Maintenance Channel from bulkhead
FB	31 - 28	G5, A, M		--
FC	27 - 24	Spare		--
EB	23 - 20	O	1 - 4	--
EC	19 - 16	C	1 - 4	--
DB	15 - 12	N	1 - 4	--
DC	11 - 8	J	1 - 4	
CB	7 - 4	N	5 - 8	--
CC	3 - 0	B	5 - 8	--
DA, CA	--	--	--	Passon Channel from IO module

MWS Connectors

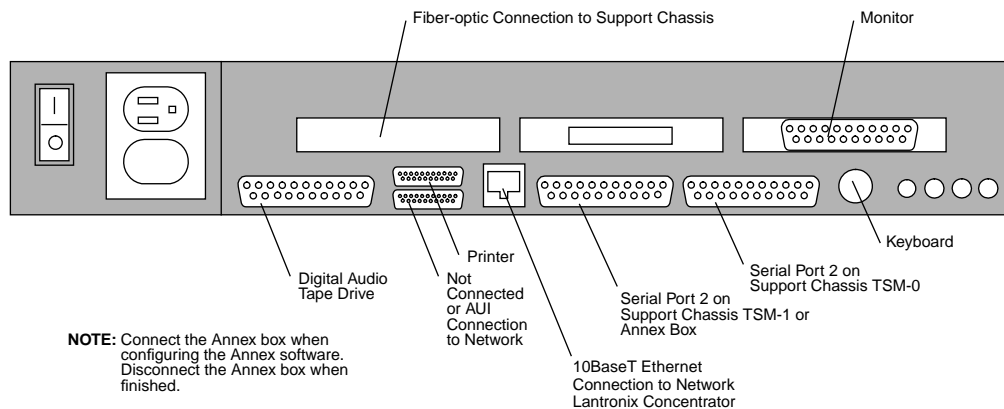

OWS Connectors

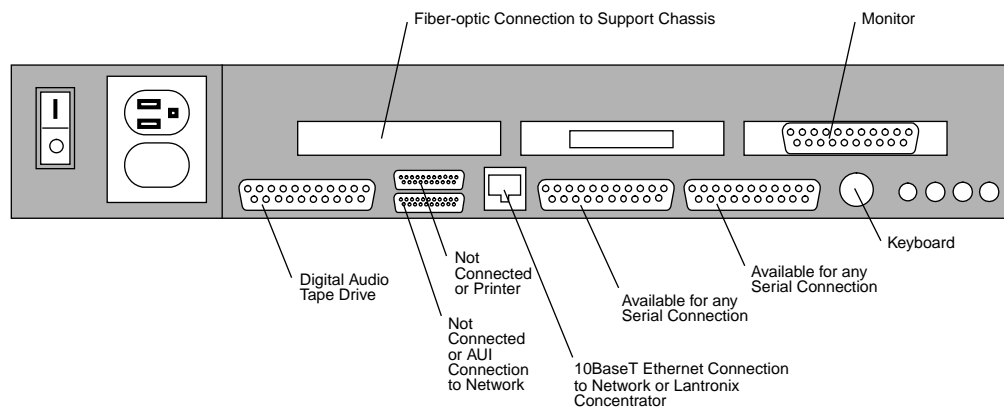

SWS Connectors

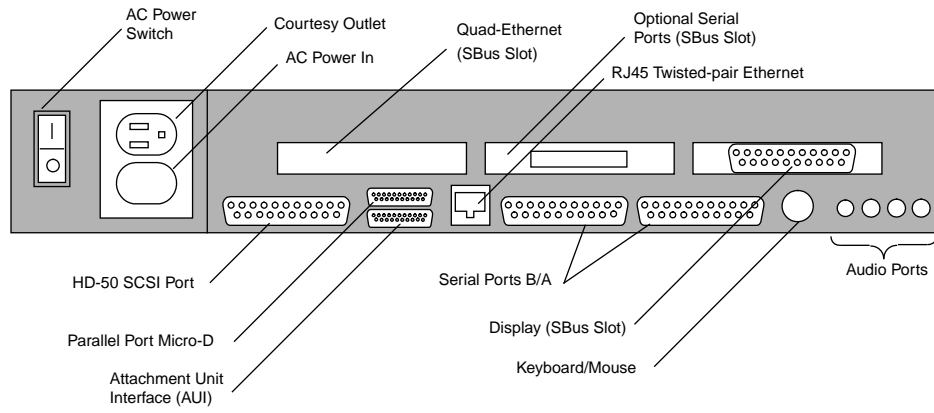

Micro Annex Connectors

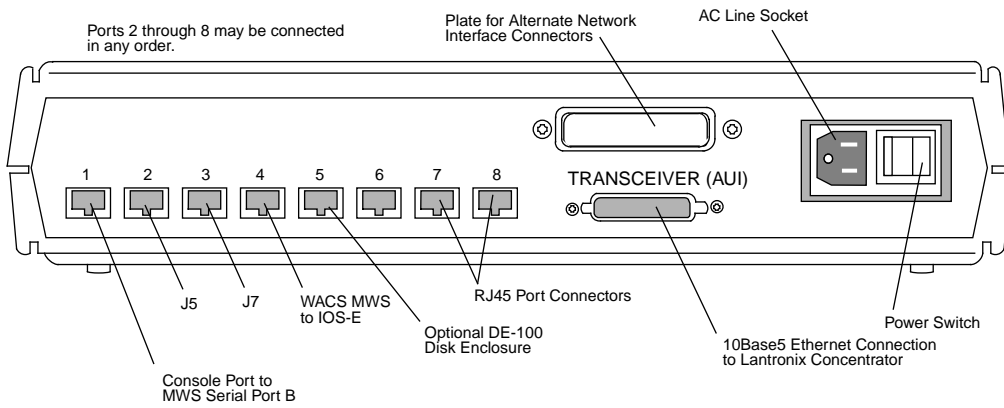

Lantronix Concentrator Connectors

Ports 1 through 7 may be connected in any order.

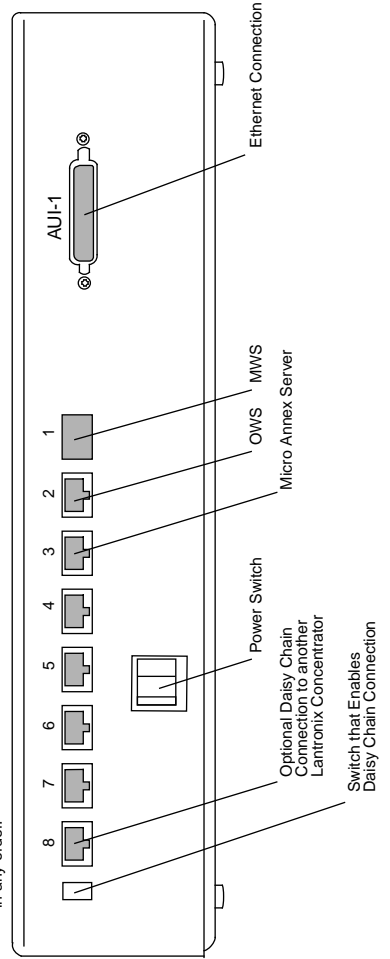

CPE1 Module Board 1

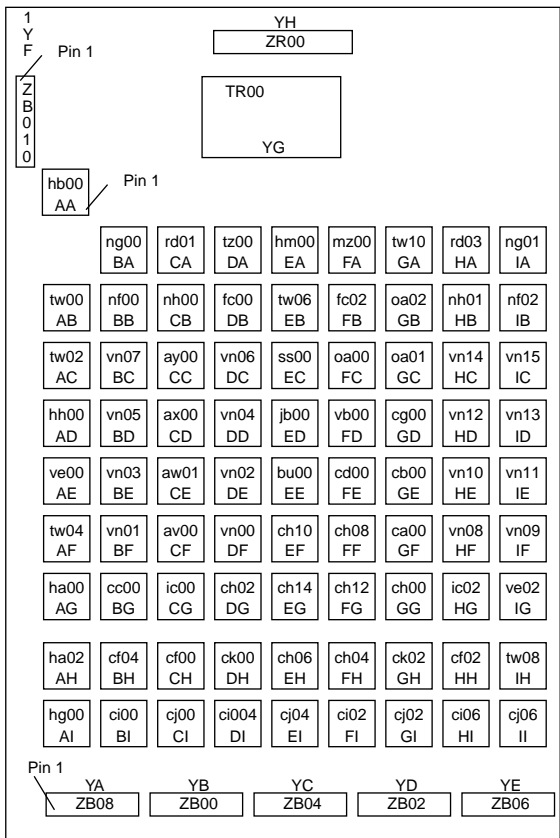

CPE1 Module Board 2

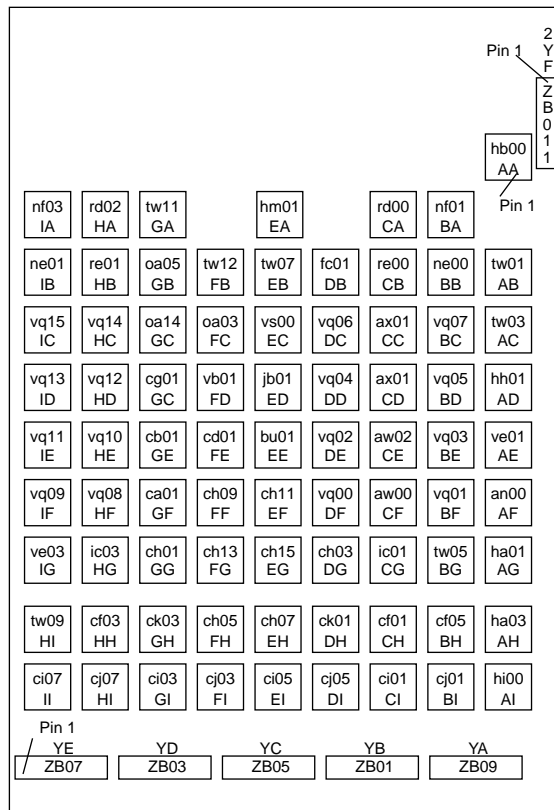

SR01 Module Board 1

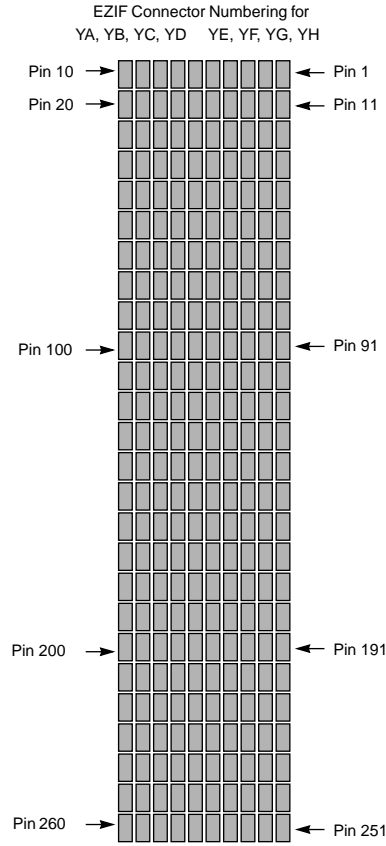
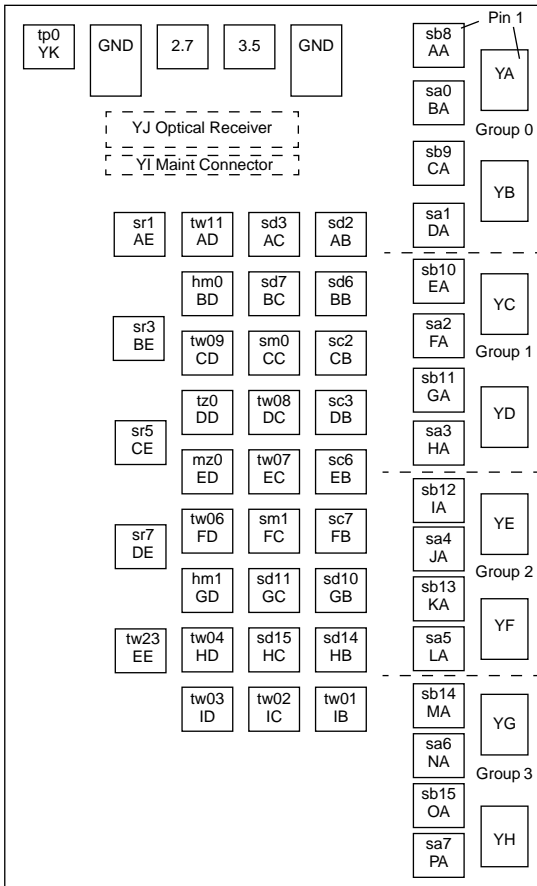

SR01 Module Board 2

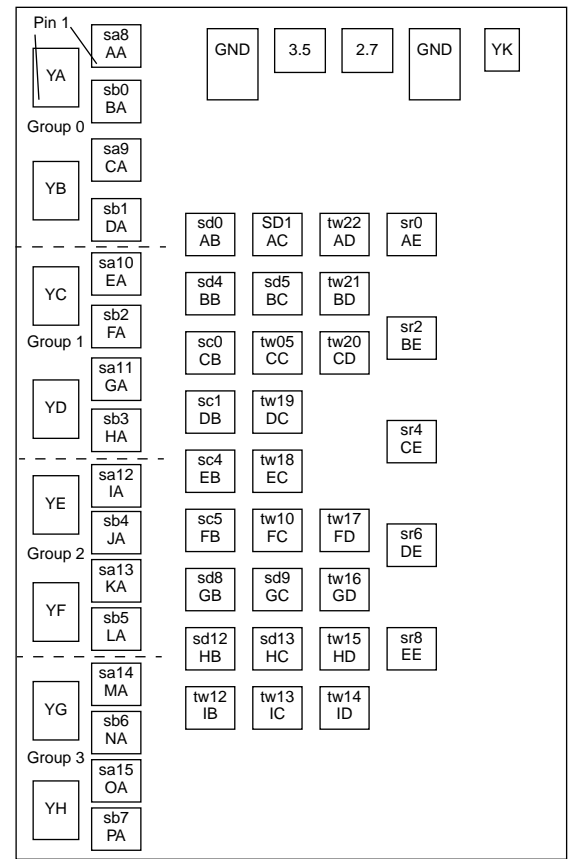
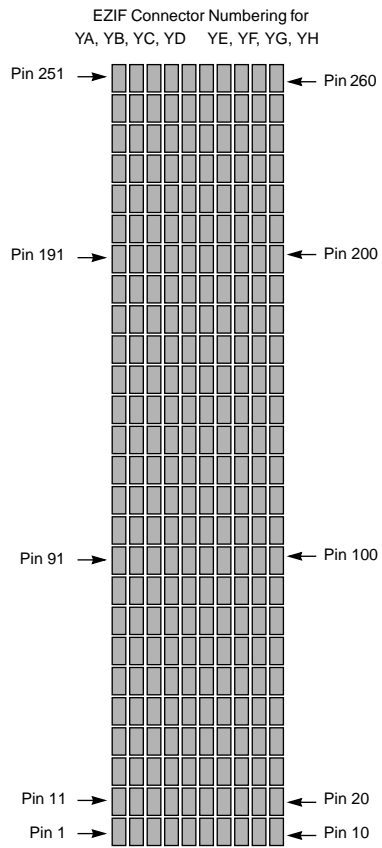

CM02 Module Board 1

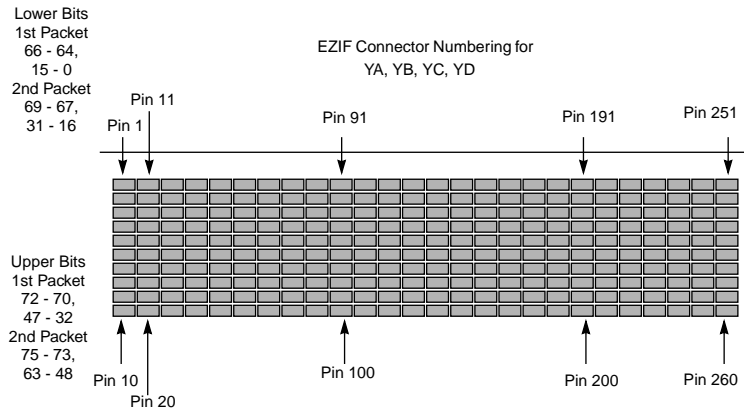
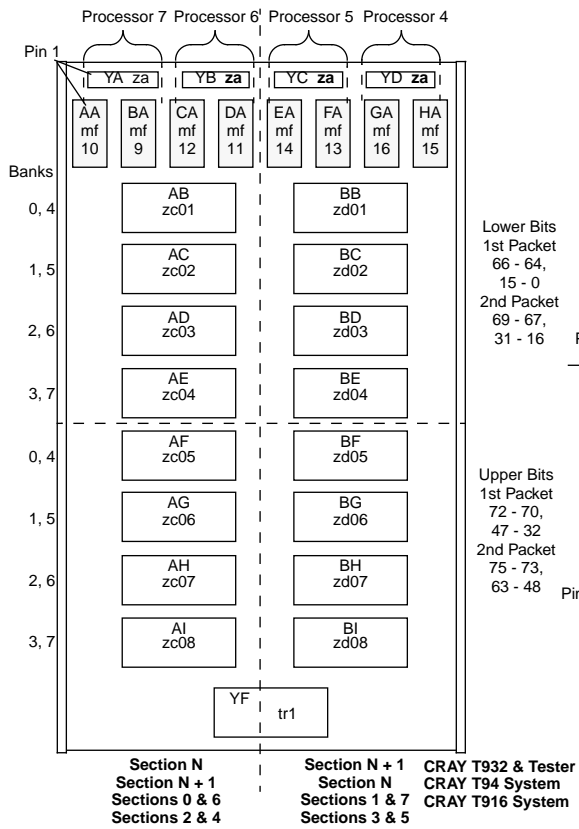

CM02 Module Board 2

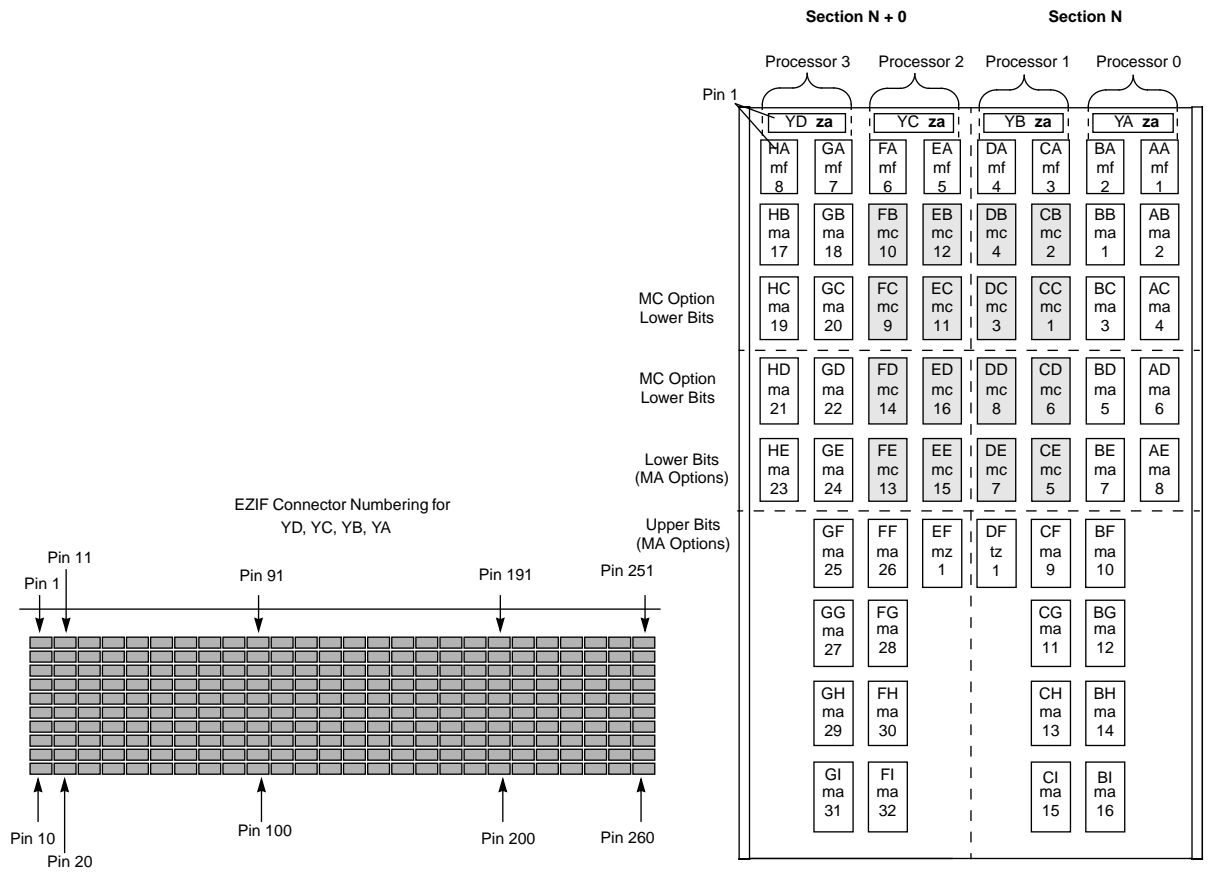

CM03 Module Board 1

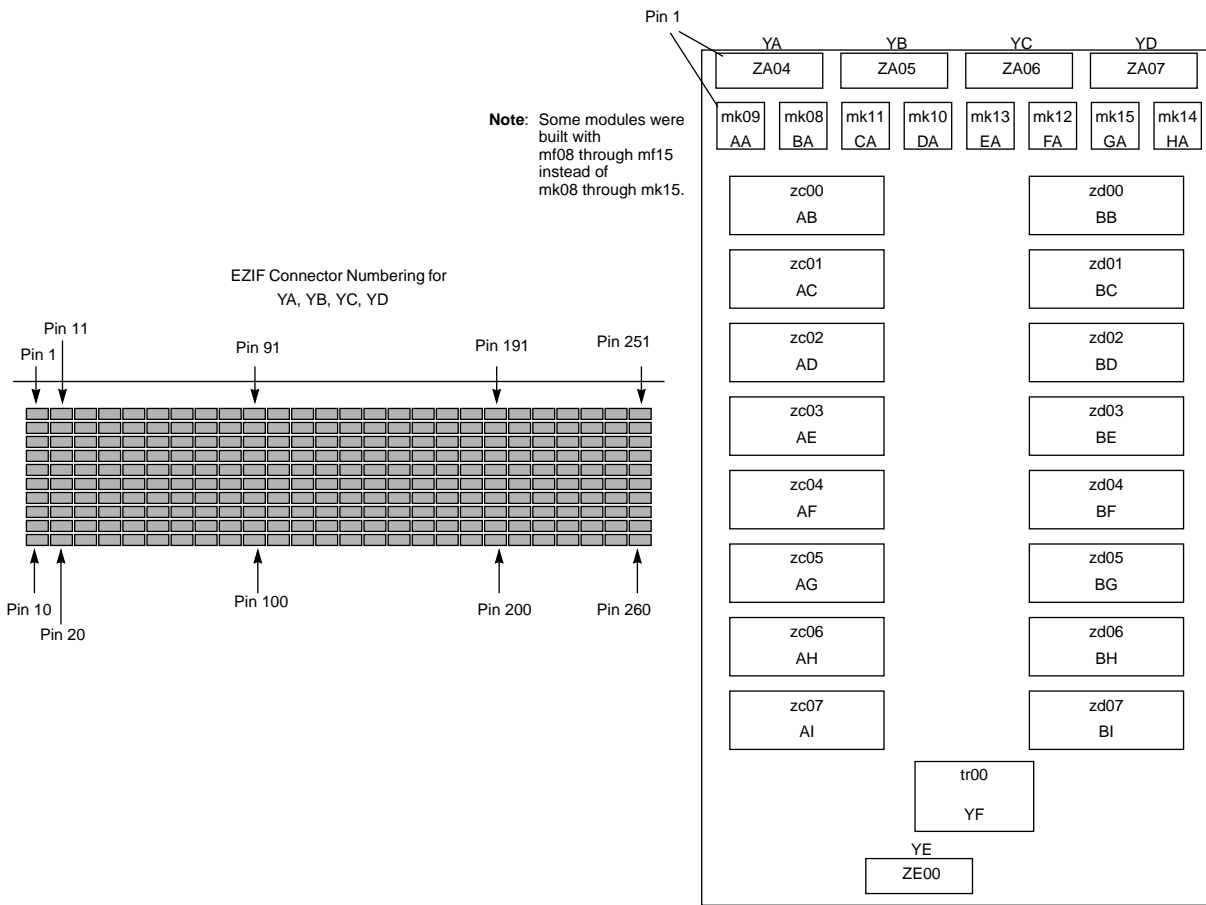

CM03 Module Board 2

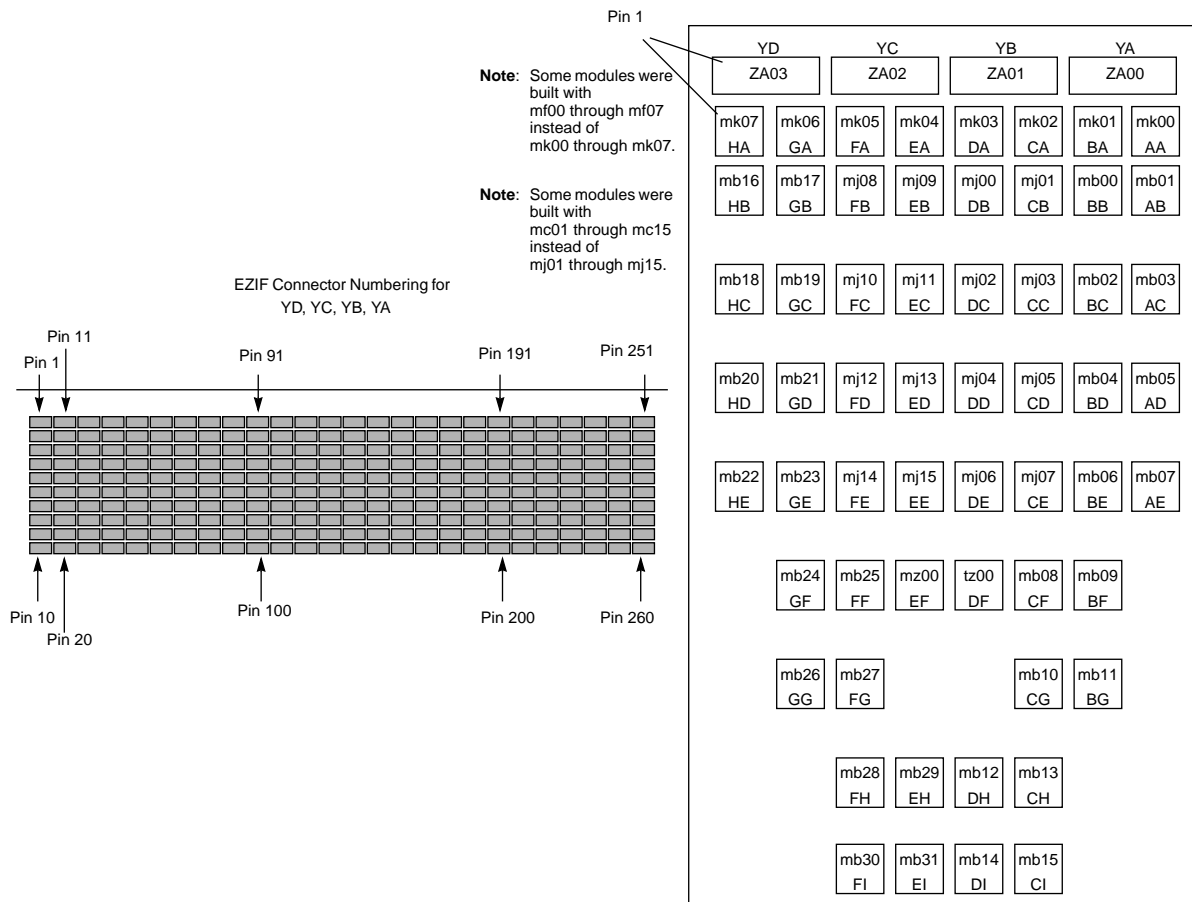

CM04 Module Board 1

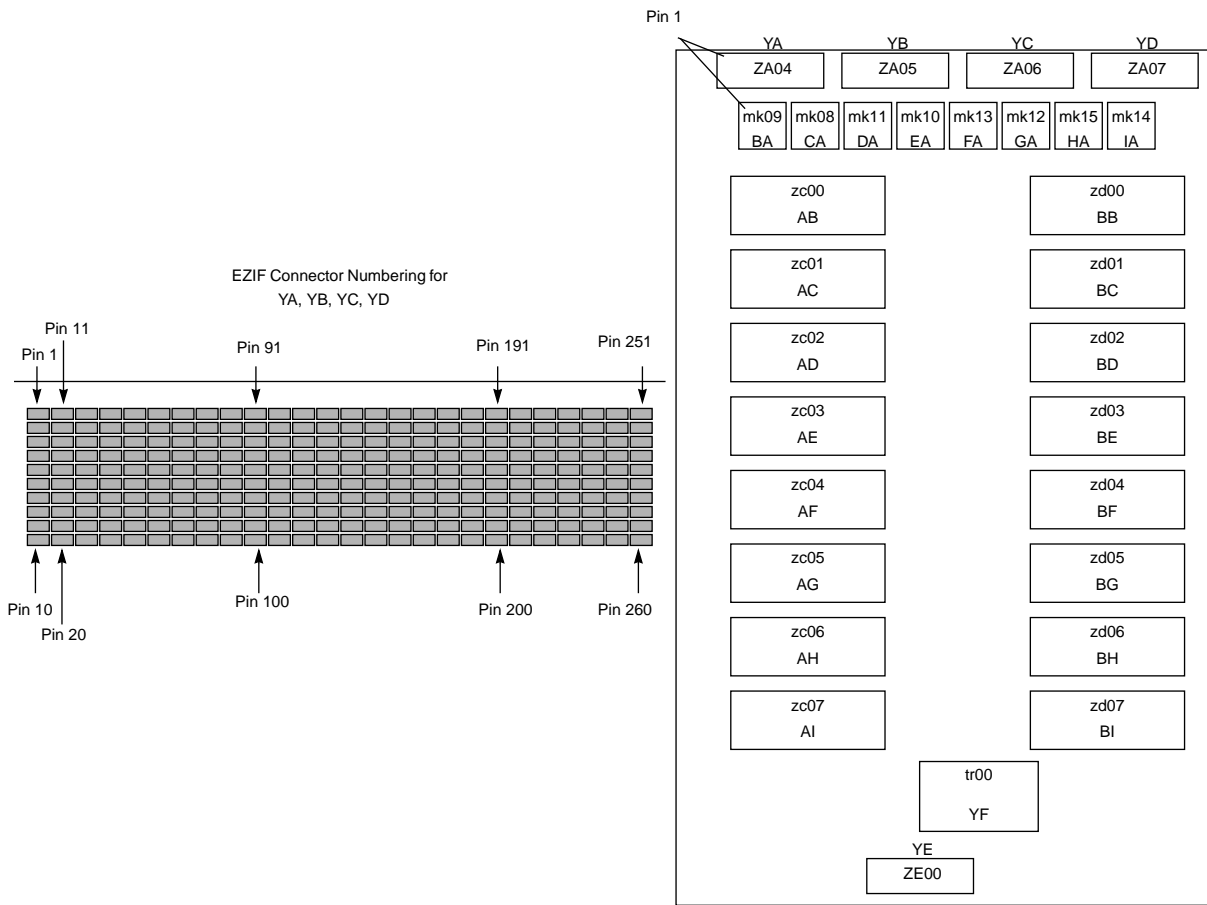

CM04 Module Board 2

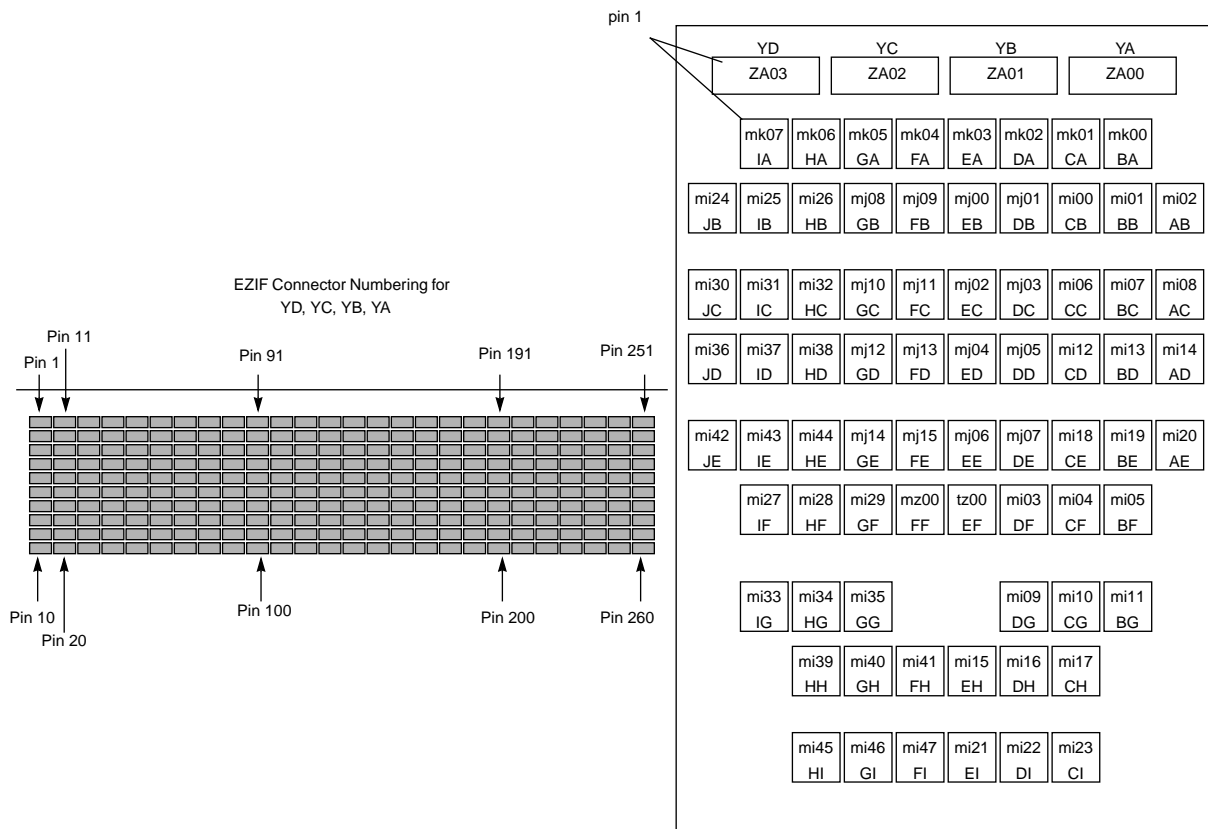

IO01 Module Board 1

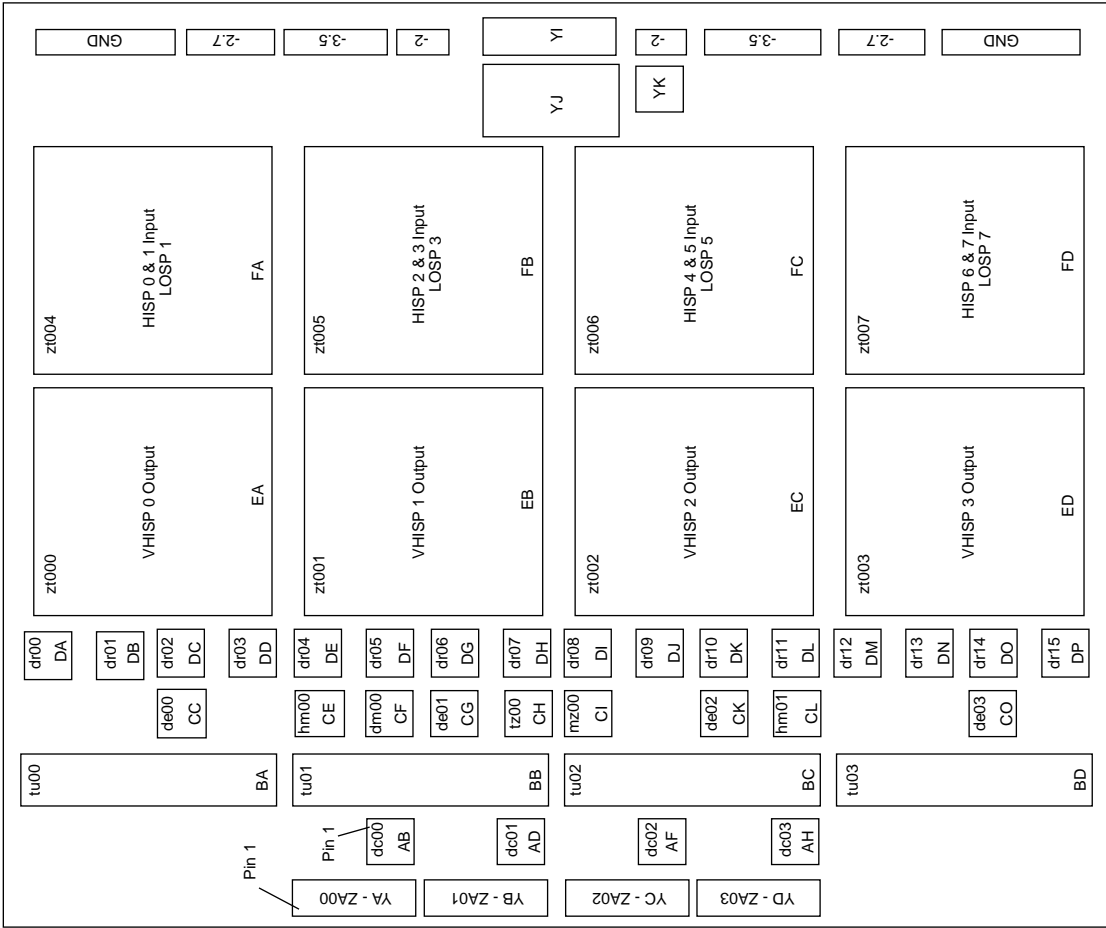

IO01 Module Board 2

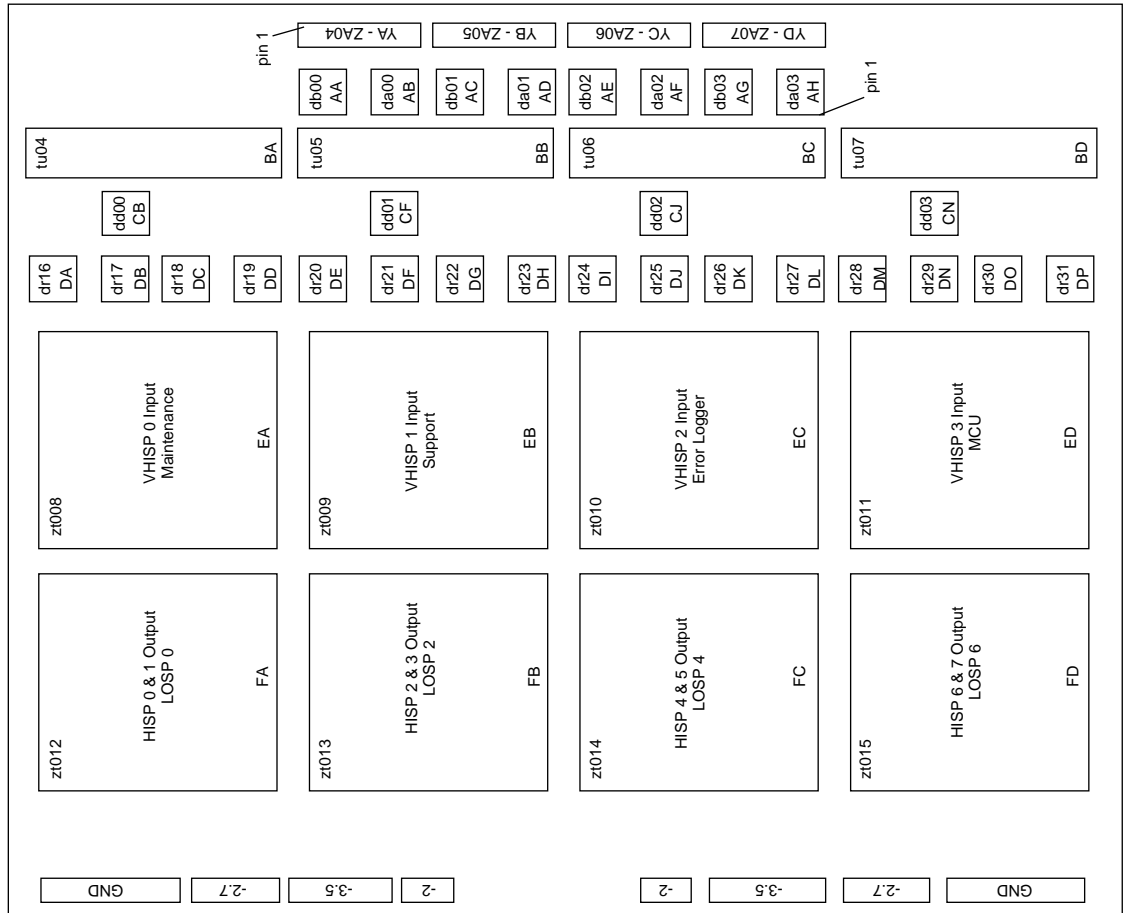

IO02 Module Board 1

From top to bottom: QC00 @ RM, QC01 @ RN, QC02 @ RO, QC03 @ RP

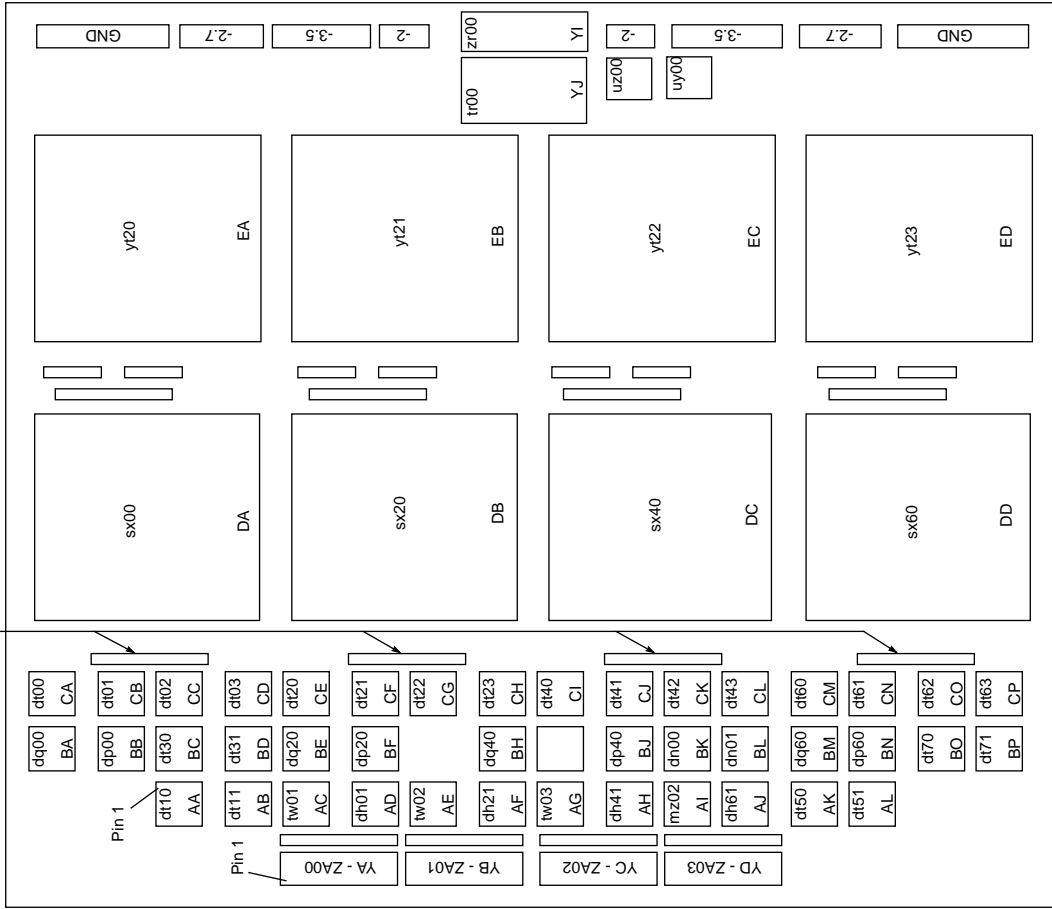

IO02 Module Board 2

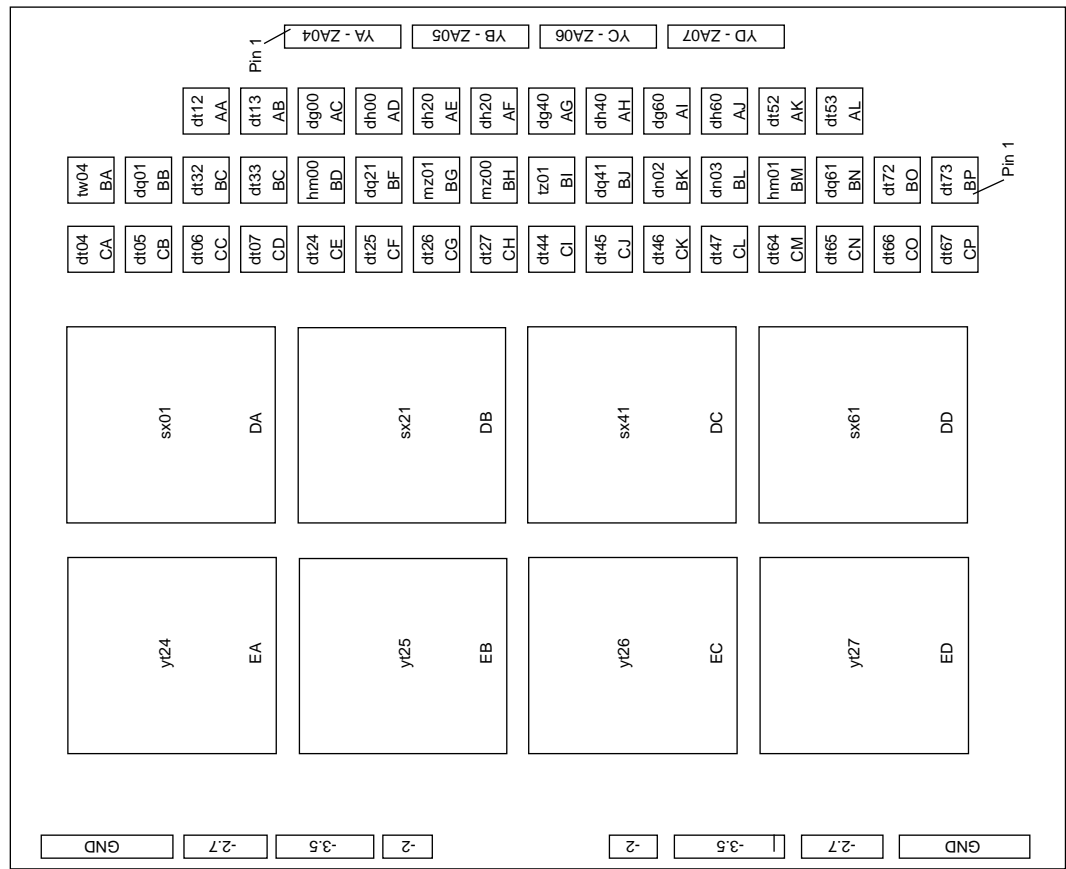

NW01 Module Board 1

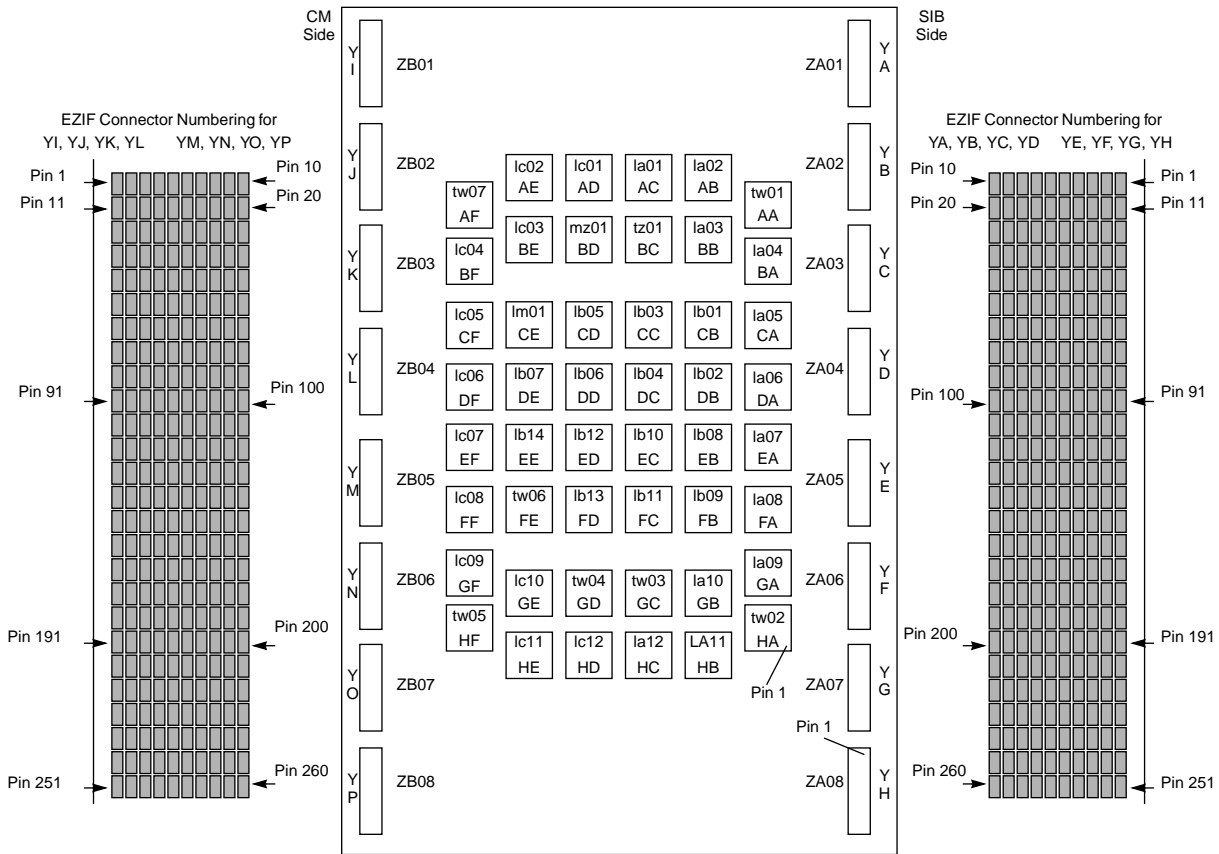

NW01 Board 2

