



System Overview
(CRAY SV1™ Series)

108-0196-003.1

Cray Proprietary

(c) Cray Inc. All Rights Reserved. Unpublished Proprietary Information. This unpublished work is protected by trade secret, copyright, and other laws. Except as permitted by contract or express written permission of Cray Inc., no part of this work or its content may be used, reproduced, or disclosed in any form.

U.S. GOVERNMENT RESTRICTED RIGHTS NOTICE: The Computer Software is delivered as "Commercial Computer Software" as defined in DFARS 48 CFR 252.227-7014. All Computer Software and Computer Software Documentation acquired by or for the U.S. Government is provided with Restricted Rights. Use, duplication or disclosure by the U.S. Government is subject to the restrictions described in FAR 48 CFR 52.227-14 or DFARS 48 CFR 252.227-7014, as applicable. Technical Data acquired by or for the U.S. Government, if any, is provided with Limited Rights. Use, duplication or disclosure by the U.S. Government is subject to the restrictions described in FAR 48 CFR 52.227-14 or DFARS 48 CFR 252.227-7013, as applicable.

Autotasking, CF77, Cray, Cray Ada, Cray Channels, Cray Chips, CraySoft, Cray Y-MP, Cray-1, CRInform, CRI/TurboKiva, HSX, LibSci, MPP Apprentice, SSD, SuperCluster, UNICOS, UNICOS/mk, and X-MP EA are federally registered trademarks and Because no workstation is an island, CCI, CCMT, CF90, CFT, CFT2, CFT77, ConCurrent Maintenance Tools, COS, Cray Animation Theater, Cray APP, Cray C90, Cray C90D, Cray CF90, Cray C++ Compiling System, CrayDoc, Cray EL, Cray Fortran Compiler, CrayLink, Cray J90, Cray J90se, Cray J916, Cray J932, Cray MTA, Cray MTA-2, Cray MTX, Cray NQS, Cray/REELlibrarian, Cray S-MP, Cray SSD-T90, Cray SV1, Cray SV2, Cray SX-5, Cray SX-6, Cray T90, Cray T94, Cray T916, Cray T932, Cray T3D, Cray T3D MC, Cray T3D MCA, Cray T3D SC, Cray T3E, CrayTutor, Cray X1, Cray X-MP, Cray XMS, Cray-2, CSIM, CVT, Delivering the power..., DGauss, Docview, EMDS, GigaRing, HEXAR, IOS, ND Series Network Disk Array, Network Queuing Environment, Network Queuing Tools, OLNETH, RQS, SEGLDR, SMARTE, SUPERLINK, System Maintenance and Remote Testing Environment, Trusted UNICOS, UNICOS MAX, and UNICOS/mp are trademarks of Cray Inc.

The UNICOS, UNICOS/mk, and UNICOS/mp operating systems are derived from UNIX System V. These operating systems are also based in part on the Fourth Berkeley Software Distribution (BSD) under license from The Regents of the University of California.

All other trademarks are the property of their respective owners.

Direct requests for copies of publications to:

Mail: Cray Inc. Logistics
PO Box 6000
Chippewa Falls, WI 54729-0080
USA

E-mail: spares@cray.com

Web: <http://techinfo.us.cray.com/doc.htm>

Select the document that you want and click the Order Form link at the bottom of its summary page.

Fax: +1 715 726 4602

Direct comments about this publication to:

Mail: Cray Inc.
Technical Training and Documentation
P.O. Box 6000
Chippewa Falls, WI 54729-0080
USA

E-mail: ttd_online@cray.com

Fax: +1 715 726 4991

System Overview

108-0196-003

CRAY SV1™ Series Systems

Last Modified: March 2001

Record of Revision	2
Introduction to CRAY SV1 Series	3
Processor Module	8
Memory Module	9
Scalable I/O Architecture	10
MPNs	11
SPNs	12
PC-10 Models	13
Power, Cooling, and Control	14
CCU	15
Mainframe Power	15
Mainframe Cooling	15
PC-10 CCU Functions	15
PC-10 Power	16
PC-10 Cooling	16
Diagnostics	17
Operating Systems	18
System Workstation	19

Figures

Figure 1.	Basic CRAY SV1 Series Computer Systems	3
Figure 2.	CRAY SV1-1A Series Chassis Layout (Rear View)	5
Figure 3.	CRAY SV1-1 Series Chassis Layout (Rear View)	6
Figure 4.	SIO Elements	10
Figure 5.	MPN	11
Figure 6.	SPNs in an NSR	12
Figure 7.	System Workstation	19

Tables

Table 1.	CRAY SV1 Series Models	4
Table 2.	CRAY SV1 Series Single-cabinet Configurations	7
Table 3.	CRAY SV1ex Series Single-cabinet Configurations	7

Record of Revision

November 1998

Original printing.

January 2000

This revision incorporates changes based on reader comments and user feedback.

March 2001

This revision incorporates the CRAY SV1ex series system into the CRAY SV1 series overview information.

Introduction to CRAY SV1 Series

CRAY SV1 series computer systems, shown in Figure 1, are multiprocessor systems with efficient scalar and vector processing capabilities, large memory, high memory bandwidth, and efficient input/output (I/O) capabilities. The modular design enables the customer to perform separate upgrades of the central processing unit (CPU), memory, and scalable input/output (SIO) components.

Figure 1. Basic CRAY SV1 Series Computer Systems

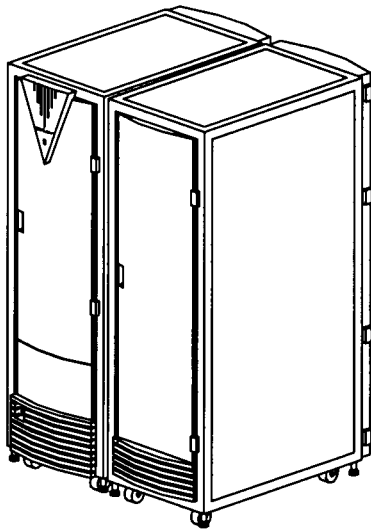

CRAY SV1-1A

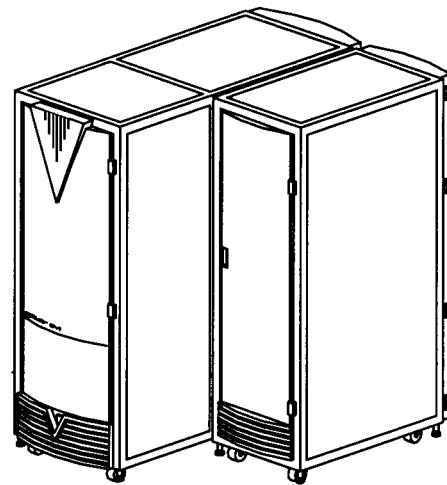

CRAY SV1-1

CRAY SV1 series systems include the CRAY SV1-1 and SV1-1A and the new CRAY SV1ex-1 and SV1ex-1A models. Because the new CRAY SV1e processor and the CRAY SV1ex memory subsystem will be available at nearly the same time, they are marketed as a single enhancement, the CRAY SV1ex system. The following example explains the naming conventions for the CRAY SV1 series configurations:

CRAY SV1ex-1A/12-16

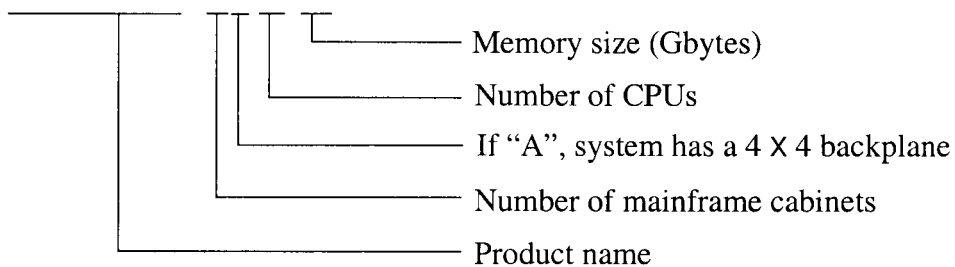

Each model includes a mainframe cabinet and a minimum of one SIO peripheral cabinet (PC-10). The mainframe cabinet houses the processor and memory modules along with the system clock. The processor modules contain the CPU components, and the memory modules contain the memory components; both reside in a backplane or midplane card cage.

Table 1 describes the memory and processor module configurations for both of the CRAY SV1 series models. Figure 2 and Figure 3 show possible chassis layouts of the CRAY SV1-1A and SV1-1 series systems.

Note: Unless otherwise noted, the term CRAY SV1 series systems includes the CRAY SV1-1 and SV1-1A and the new CRAY SV1ex-1 and SV1ex-1A models. In addition, the term CRAY SV1-1A series indicates both the CRAY SV1-1A and SV1ex-1A systems and the term CRAY SV1-1 series includes the CRAY SV1-1 and the CRAY SV1ex-1 systems.

Table 1. CRAY SV1 Series Models

Model	Backplane or Midplane	Memory Modules	Processor Modules	CPUs
CRAY SV1-1A and SV1ex-1A	4X4	4	2 to 4	8 to 16
CRAY SV1-1 and SV1ex-1	8X8	8	2 to 8	8 to 32

The backplane/midplane configurations listed in Table 1 refer to the maximum number of processor modules and memory modules that the backplane or midplane can accommodate. All of the memory slots are always occupied; however, all of the processor module slots may not be occupied. Processor slot 0 must be occupied and marketing rules require that one additional slot be occupied for a minimum of two processor modules. The maximum configurations are two to four processor modules in a CRAY SV1-1A series system and two to eight processor modules in a CRAY SV1-1 series system.

The SIO architecture is a multicabinet (PC-10), air-cooled system that provides scalable high-performance and high-resilience I/O support for CRAY SV1 series computer systems. SIO data and control information transmits over GigaRing channels. The flexibility of the GigaRing channel architecture enables multiple system configurations with system functionality and performance that are appropriate to the needs of the customer.

The CRAY SV1 series systems are air-cooled and do not require a raised-floor system. Computer room operating requirements are given in *CRAY SV1-1 Series Power, Cooling, and Control*, publication number 108-0201 and *CRAY SV1-1A Series Power, Cooling, and Control*, publication number 108-0200.

CRAY SV1 series systems include from 8 to 32 CPUs with 4 CPUs contained on a single processor module. The existing CRAY SV1 memory options range from 4096 Mbytes to 32768 Mbytes; the CRAY SV1ex memory is available in 32768 Mbytes with 0, 32768, or 98384 Mbytes of SSDI space. Table 2 lists the existing CRAY SV1 series configurations and Table 3 lists the new CRAY SV1ex series configurations.

Figure 2. CRAY SV1-1A Series Chassis Layout (Rear View)

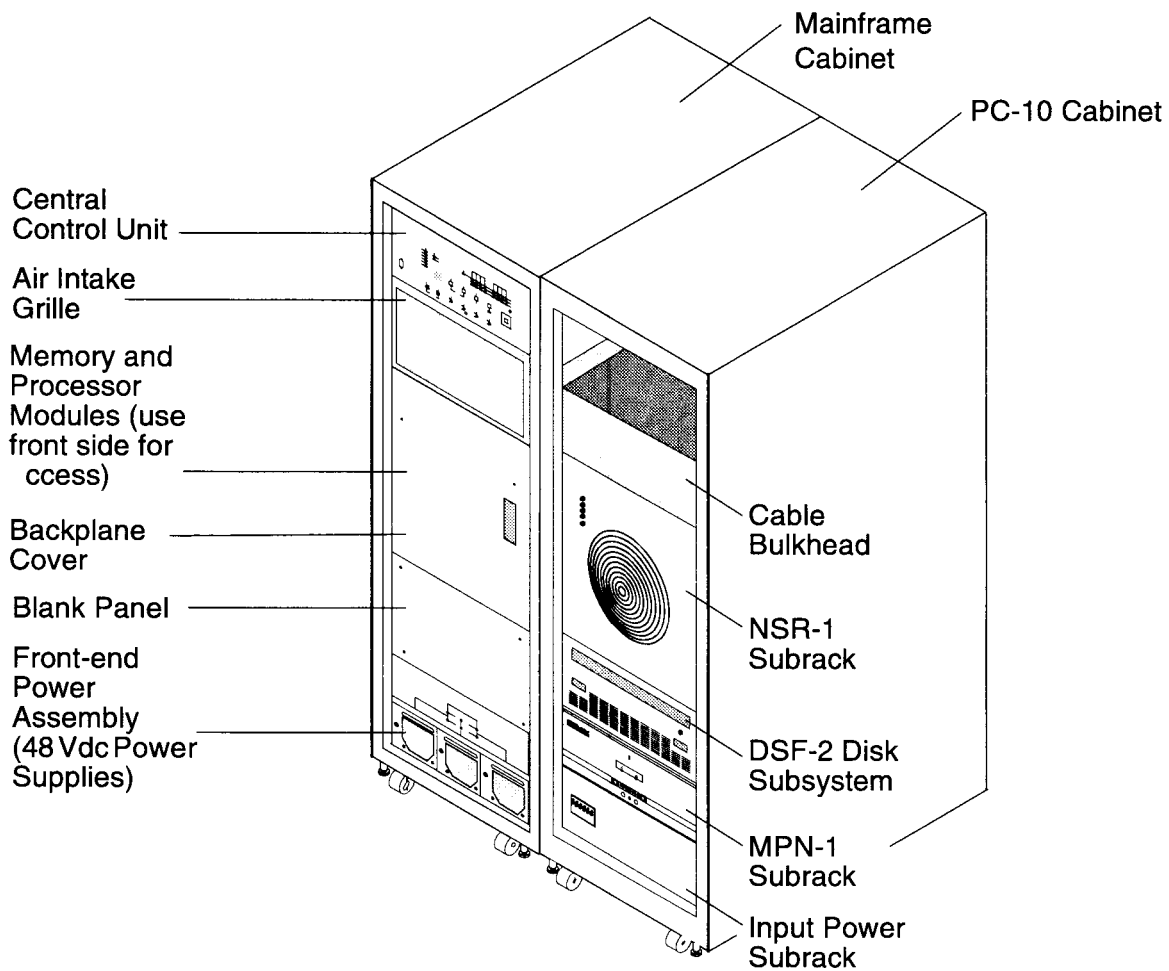

Figure 3. CRAY SV1-1 Series Chassis Layout (Rear View)

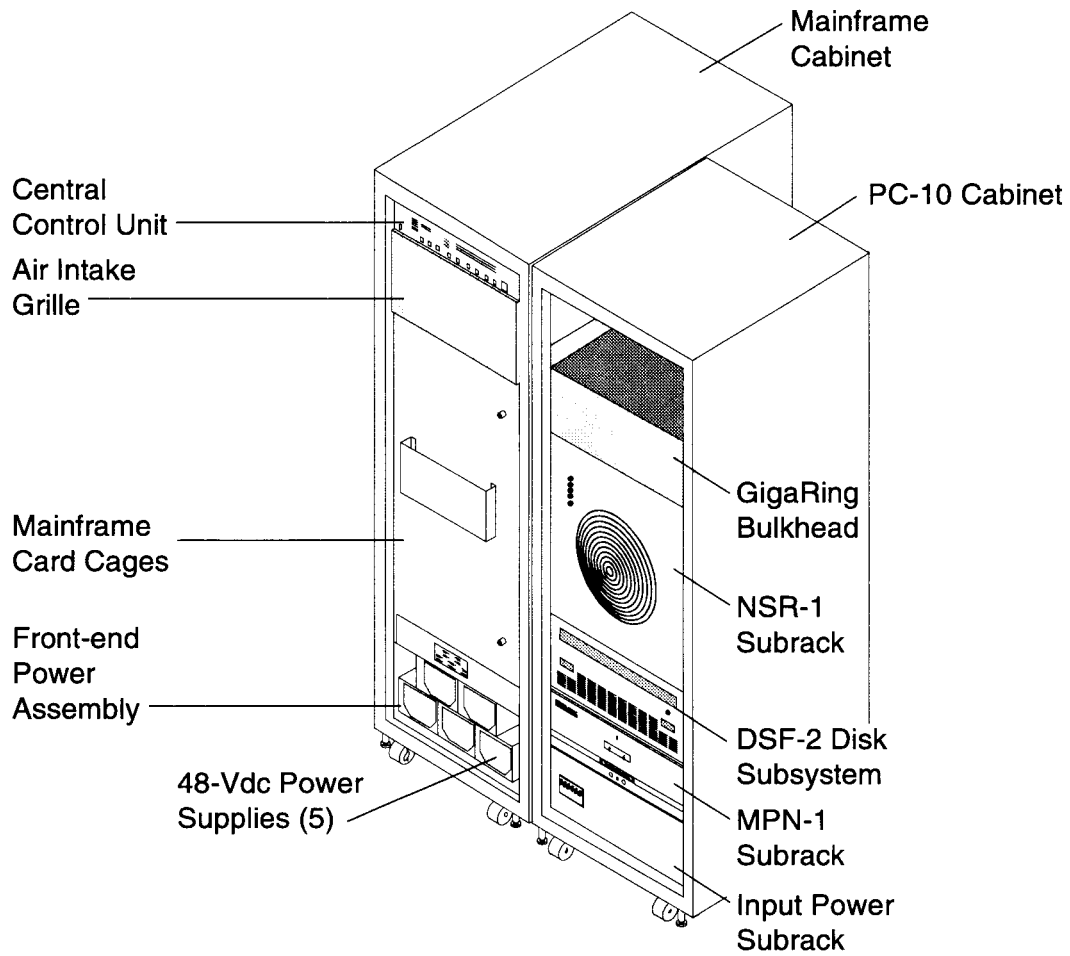

Table 2. CRAY SV1 Series Single-cabinet Configurations

Product Name	Number of Mainframe Cabinets	Total Number of CPUs	Total Memory (Mbytes)
SV1-1A/8-4	1	8	4096
SV1-1A/8-16	1	8	16384
SV1-1A/12-4	1	12	4096
SV1-1A/12-16	1	12	16384
SV1-1A/16-4	1	16	4096
SV1-1A/16-16	1	16	16384
SV1-1/16-8	1	16	8192
SV1-1/16-32	1	16	32768
SV1-1/24-8	1	24	8192
SV1-1/24-32	1	24	32768
SV1-1/32-8	1	32	8192
SV1-1/32-32	1	32	32768

Table 3. CRAY SV1ex Series Single-cabinet Configurations

Product Name	Number of Mainframe Cabinets	Total Number of CPUs	User Memory (Mbytes)	SSD Memory (Mbytes)
SV1ex-1A/8-32	1	8	32768	None
SV1ex-1A/8-64	1	8	32768	32768
SV1ex-1A/12-32	1	12	32768	None
SV1ex-1A/12-64	1	12	32768	32768
SV1ex-1A/16-32	1	16	32768	None
SV1ex-1A/16-64	1	16	32768	32768
SV1ex-1/16-64	1	16	32768	32768
SV1ex-1/16-128	1	16	32768	98304
SV1ex-1/24-64	1	24	32768	32768
SV1ex-1/24-128	1	24	32768	98304
SV1ex-1/32-64	1	32	32768	32768
SV1ex-1/32-128	1	32	32768	98304

Processor Module

Each CRAY SV1 series processor module contains four CPUs. Each CPU includes a scalar processor and a vector processor; both processors consist of operating registers, functional units, and a control section. Refer to the document entitled *Processor and Memory Components*, publication number 108-0197, for more detailed information on the CPU.

The SV1e processor operates at a clock frequency of 500 MHz. The current CRAY SV1 CPU system clock speed remains at 300 MHz.

Each CPU scalar processor contains eight 64-bit scalar (S) registers and a 256-Kbyte, 32-Kword, 4-way set-associative cache. Each SV1 scalar processor features a scalar processing rate of 300 million instructions per second (MIPS) and each SV1e scalar processor features 500 MIPS.

Each CPU vector processor contains eight 64-bit by 64-element vector registers. The peak vector processing rate is approximately 1 GFLOP per CPU for a CRAY SV1 system and 2 GFLOPs per CPU for a CRAY SV1ex system. Each CPU control section contains eight 32-bit address (A) registers, sixty-four 32-bit intermediate address (B) registers, sixty-four 64-bit intermediate scalar (T) registers, and eight 32-word instruction buffers that each store thirty-two 64-bit words.

Each processor module contains four CPUs on one printed circuit board (PCB). Processor modules with the SIO GigaRing channel adapter contain two additional PCBs. The CRAY SV1 series GigaRing channel adapter provides the interface between the GigaRing channel and the CPU.

The CRAY SV1 series systems include a performance monitor that tracks groups of hardware-related events. The performance monitor is a set of registers that are used by system analysts to monitor operating software on a system. Software utilities allow the user to select and read the performance monitor.

The CRAY SV1 processor modules use application-specific integrated circuit (ASIC) technology. Each module comprises an array of ASICs, which are based on very large-scale integrations (VLSI) complementary metal oxide semiconductor (CMOS) technology. These ASICs contain more than 1.6 million gates each.

Memory Module

Memory components are distributed across all memory modules; the number of components depends on the configuration. Refer to Table 2 on page 7 for CRAY SV1 memory configurations and Table 3 for CRAY SV1ex memory configurations. CRAY SV1ex memory contains an on-board solid-state device (SSD) memory that enables high-speed transfer of data between main memory and SSD memory.

The CRAY SV1 memory contains dynamic random-access memory (DRAM) chips that provide storage for data and correction bits. Two sizes of memory chips are available: 16-Mbit DRAMs or 64-Mbit DRAMs. The DRAM chips have a 50-ns access time.

The CRAY SV1ex memory module contains static dynamic random-access memory (SDRAM) chips. These SDRAM chips have a 37.5-ns access time.

CRAY SV1 central memory consists of 8 sections. Each CRAY SV1-1 memory section contains 8 subsections, and each CRAY SV1-1A memory section contains 4 subsections. CRAY SV1ex-1A and CRAY SV1ex-1 memory include 8 sections with 16 subsections per section. A memory word consists of 72 bits: 64 data bits and 8 error-correction bits.

Memory is shared among all of the CPUs in the mainframe cabinet. Each CPU has two memory ports that allow it to make simultaneous memory references. A third port is used for I/O and instruction fetch operations.

Refer to the document entitled *Processor and Memory Components*, publication number 108-0197, for more detailed information on memory.

Scalable I/O Architecture

The CRAY SV1 series systems support connections to a variety of disk, tape, and network peripheral subsystems through the SIO architecture. The basic elements of the SIO architecture are the GigaRing channel, input/output nodes (IONs), and the system workstation (SWS).

Figure 4. SIO Elements

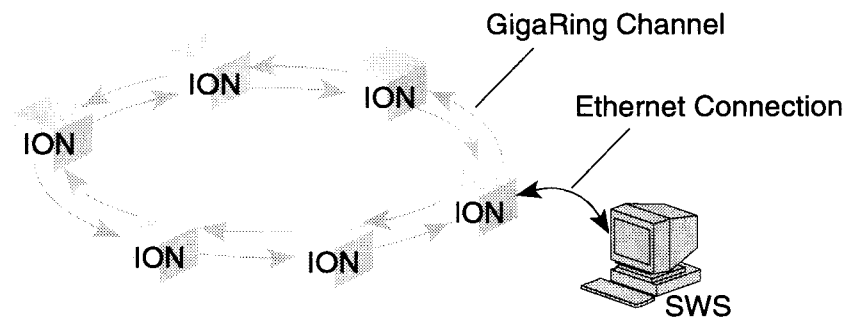

The GigaRing channel is a flexible and scalable channel that standardizes system interconnection and communication across all system peripherals and the mainframe computer. The GigaRing channel consists of a pair of counter-rotating rings, which form a single logical channel.

An ION is any device that connects directly to the GigaRing channel; for example, mainframes, multipurpose nodes (MPNs), and single-purpose nodes (SPNs). Most IONs are independent units that reside in the PC-10 and connect disk, tape, and network peripheral devices to the GigaRing channel.

The SWS serves as the maintenance and operation platform. The SWS provides support for diagnostics, monitoring, serviceability, configuration, and failure isolation through a private Ethernet connection. (Refer to Figure 7 for an illustration of the SWS.)

Disk, tape, and network IONs reside in subracks within the PC-10. The PC-10 also contains the power input subrack and several support subracks. The following subracks are available:

- Multipurpose node subrack (MPN)
- Node subrack (NSR-1)
- Ethernet concentrator
- Fibre channel disk subrack (DSF)
- Micro Annex communications server
- Fiber-optic channel extender (FOX-1)
- Power input subrack

MPNs

MPNs connect industry standard SBus-based I/O peripherals to the GigaRing channel to provide I/O services for the mainframe node. The SBus controllers reside inside the MPN (shown in Figure 5). CRAY SV1 series systems include the following industry standard SBus controllers:

- ETN-11 Ethernet network interface
- ATM-10 asynchronous transfer mode (ATM) network interface
- FDI-10 fiber distributed data interface (FDDI) network interface
- SCS-10 small computer system interface (SCSI) disk and tape drive interface
- SCS-11 SCSI disk drive interface

Figure 5. MPN

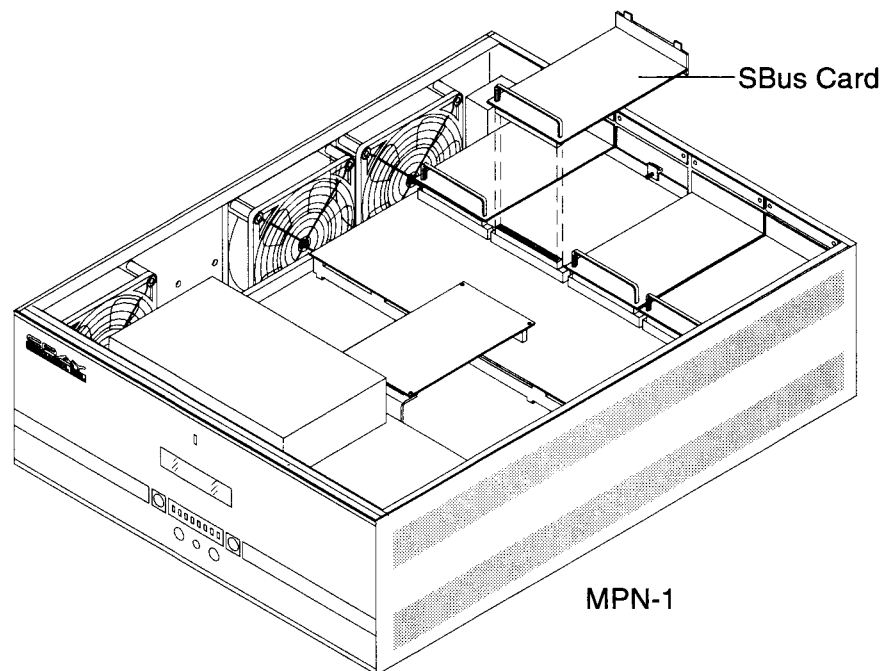

SPNs

SPNs connect specific I/O peripherals to the GigaRing channel to provide I/O services for the mainframe node. All SPNs reside in the NSR (shown in Figure 6). The NSR provides power and cooling for a maximum of four SPNs. The following disk, tape, and network SPNs are available:

- FCN-1 and FCN-2 fibre channel disk
- HPN-1 High Performance Parallel Interface (HIPPI)
- HPN-2 High Performance Parallel Interface (HIPPI)
- ESN-1 Enterprise Systems Connection Architecture/390 (ESCON) tape

Figure 6. SPNs in an NSR

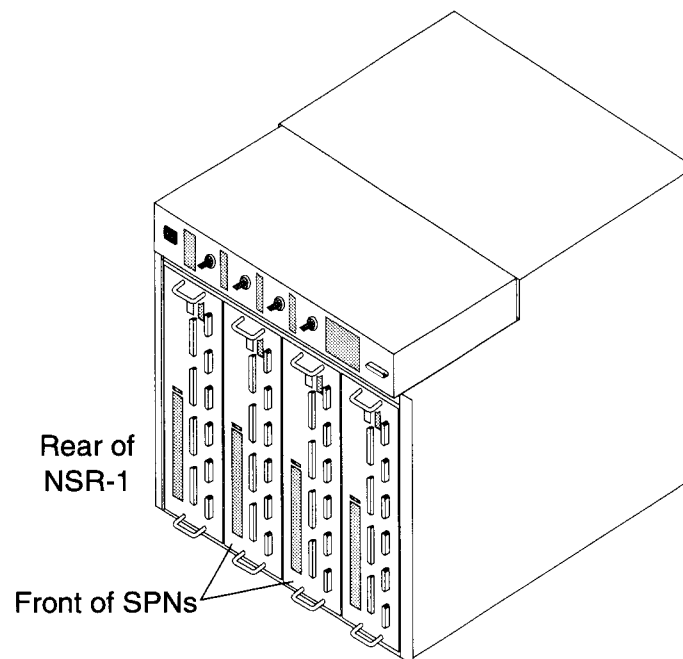

PC-10 Models

When a CRAY SV1 series mainframe is connected to PC-10A cabinets, the following PC-10 WACS features are available:

- Single-point hard reset of all MPNs
- Single-point system power-off of the connected PC-10A cabinets
- Fault light notification that a disk subrack fan failed

When a CRAY SV1 series mainframe is connected to PC-10B cabinets, the following PC-10 WACS features are available in addition to the features listed for a PC-10A:

- Remote hard reset of all MPNs
- Remote system power-off of individual PC-10B cabinets and NSRs
- Remote monitoring of individual disk subrack fans and power supplies

Power, Cooling, and Control

CRAY SV1-1A series mainframe cabinets contain one power connection; each CRAY SV1-1 series cabinets contain two power connections. The PC-10 cabinets also contain one power connection. Each mainframe power connection requires 200 to 240 Vac single-phase power at 47 to 63 Hz. Most of the CRAY SV1 peripherals in the PC-10 cabinet are packaged in 19-in. rackmount subracks that have their own power supplies and cooling fans.

For more information about CRAY SV1-1A series power, cooling, and control, refer to *CRAY SV1-1A Mainframe Cabinet Power, Cooling, and Control*, publication number 108-0200. For more information about CRAY SV1-1 series power and cooling, refer to *CRAY SV1-1 Mainframe Cabinet Power, Cooling, and Control*, publication number 108-0201. Periodically check the Technical Training and Documentation web site at the following URL for availability of these documents: <http://techinfo.cray.com/>.

Power, Cooling, and Control

CRAY SV1-1A series mainframe cabinets contain one power connection; each CRAY SV1-1 series cabinet contains two power connections. The PC-10 cabinets also contain one power connection. Each mainframe power connection requires 200 to 240 Vac single-phase power at 47 to 63 Hz. Most of the CRAY SV1 peripherals in the PC-10 cabinet are packaged in 19-in. rackmount subracks that have their own power supplies and cooling fans.

For more information about CRAY SV1-1A series power, cooling, and control, refer to *CRAY SV1-1A Mainframe Cabinet Power, Cooling, and Control*, publication number 108-0200. For more information about CRAY SV1-1 series power and cooling, refer to *CRAY SV1-1 Mainframe Cabinet Power, Cooling, and Control*, publication number 108-0201. Periodically check the Technical Training and Documentation web site at the following URL for availability of these documents: <http://techinfo.cray.com/>.

CCU

The central control unit (CCU) provides the power system monitoring and control, temperature monitoring and protection, and PC-10 fault monitoring. LEDs on the front panel of the CCU indicate system power and cooling statuses.

Mainframe Power

Mainframe power consumption depends on the customer's system configuration. Refer to *Preparing for a System Installation (CRAY SV1-1A Series)*, publication number 007-3864, for specific information about CRAY SV1-1A series systems power consumption. Refer to *Preparing for a System Installation (CRAY SV1-1 Series and Cluster Systems)*, publication number 007-3865, for specific information about CRAY SV1-1 series systems power consumption.

The single-phase mainframe AC power enters the system through one (CRAY SV1-1A series system) or two (CRAY SV1-1 series systems) power cords, which connect to an input power assembly that contains a circuit breaker and one or two line filters. The power then passes into a front-end power assembly that converts it to 48 Vdc. The 1700-W power supplies, which are in an n+1 hot-swap configuration, convert the power and provide power factor correction and isolation. The 48-Vdc power is then bused to the backplane or midplane, from which the onboard power supplies (logic power modules) receive power.

Mainframe Cooling

A single high-performance, motorized impeller blower provides cooling for the mainframe chassis. It pulls air from the upper rear area of the mainframe cabinet. This air flows through an inlet filter, through the modules, and then discharges at the lower front of the cabinet through the exhaust plenum. An interlocked damper system directs forced air that cools the processor and memory modules.

PC-10 CCU Functions

The CCU includes a control signal bus that enables the PC-10 to send fan and power supply statuses to the mainframe cabinet. Refer to the SIO system document entitled *Warning and Control System (WACS)*, publication number HTM-235, for information about the LEDs on PC-10 subracks.

A PC-10B peripheral cabinet includes a WACS unit that enables remote monitoring of the system via NWACS software on the SWS. The RS-232 port on the power input subrack is connected to one of the serial ports on the SWS. The NWACS program is used to display the status of the fault LEDs on the CCU.

PC-10 Power

PC-10 power consumption depends on the customer's system configuration. Refer to *Preparing for a System Installation (CRAY SV1-1A Series)*, publication number 007-3864, for specific information about PC-10 power consumption in a CRAY SV1-1A system. Refer to *Preparing for a System Installation (CRAY SV1-1 Series and Cluster Systems)*, publication number 007-3865, for specific information about PC-10 power consumption in a CRAY SV1-1 series system.

The PC-10 also includes an AC power input subrack that contains a circuit breaker and a line filter. Each node and peripheral subrack contains its own power connection. AC power is distributed to the subracks through a power distribution strip; each subrack plugs into this distribution strip. The Micro Annex communications server and the Ethernet concentrator plug directly into the power input subrack.

PC-10 Cooling

The PC-10 provides air inlet and exhaust ventilation. Blowers inside the node and peripheral subracks pull the air through the perforated rear door and exhaust it through the front door; no central cooling fan is required. Most node and peripheral subracks include their own fans.

Diagnostics

Note: Periodically check the Technical Training and Documentation Web site at the following URL for current CRAY SV1 series documents: <http://techinfo.cray.com/>.

Standard UNICOS online diagnostics and utilities as well as offline diagnostics are available for troubleshooting CRAY SV1 series systems. The primary tool for running offline mainframe diagnostics is the automated confidence testing (ACT) menu interface. The CRAY J90 maintenance console (JMC) software can also be used to run offline mainframe diagnostics.

ACT is a suite of shell scripts and C applications that detect and isolate mainframe hardware failures in CRAY SV1 series systems. ACT provides two levels of system testing. The first level of testing in ACT is invoked automatically after the system is powered up and the ION VxWorks operating system is loaded. The power-up tests isolate defective system components and record or display the error information. The second level of testing, the ACT menu system, provides a menu-driven interface that is used to select and run specific diagnostics. Each level can be used by on-site, remote-support, or escalated-support service personnel to troubleshoot the system.

For more information on ACT, refer to *CRAY SV1 Mainframe Troubleshooting*, publication number 108-0202.

SIO diagnostic tools are available in addition to mainframe diagnostics; refer to the Technical Training and Documentation Web site at the following URL for availability of SIO documents: <http://techinfo.cray.com/>.

Operating Systems

The CRAY SV1 series systems function with two distinct operating systems: the UNICOS operating system for the mainframe and the VxWorks operating system for the SIO architecture.

The UNICOS kernel and configuration files reside on the system workstation. However, once these files are loaded into central memory and the kernel is booted, the UNICOS operating system operates in central memory. The UNICOS supporting files reside on the large-capacity system disk drives.

The UNICOS operating system uses a standard UNIX System V environment. It also complies with the Portable Operating System Interface (POSIX) standard for computer environments. The UNICOS operating system incorporates enhancements that provide more efficient parallel/vector processing, increased security, and more versatile network connectivity. UNICOS 10.0.0.7 or later is required for CRAY SV1 series systems. A minimum of UNICOS 10.0.1.0 will be used with CRAY SV1ex systems.

The VxWorks operating system is a real-time operating system that has been tuned to provide highly efficient I/O control.

System Workstation

The system workstation (SWS) for CRAY SV1 series systems is a Sun Microsystems, Inc. Sun Ultra 5 Model 360. Refer to Figure 7 for an illustration of the SWS. The CPU unit is configured with an 8.4-Gbyte, 5400 rpm EIDE (Enhanced Integrated Drive Electronics) hard disk drive, a Quad Ethernet card with PCI bus, and onboard video capabilities.

Note: This workstation is designed to support CRAY SV1 series system software and hardware maintenance activities. Use of this system workstation for other purposes may cause the system to operate unpredictably.

The SWS provides a CD-ROM drive for loading software and a system disk that stores the SIO kernel and configuration files, SIO and mainframe utilities and diagnostics, and other maintenance files. An external digital audio tape (DAT) drive that connects to the SWS is used to back up the SWS, to send diagnostic information to Central Repair, and to return UNICOS dumps for analysis.

Figure 7. System Workstation

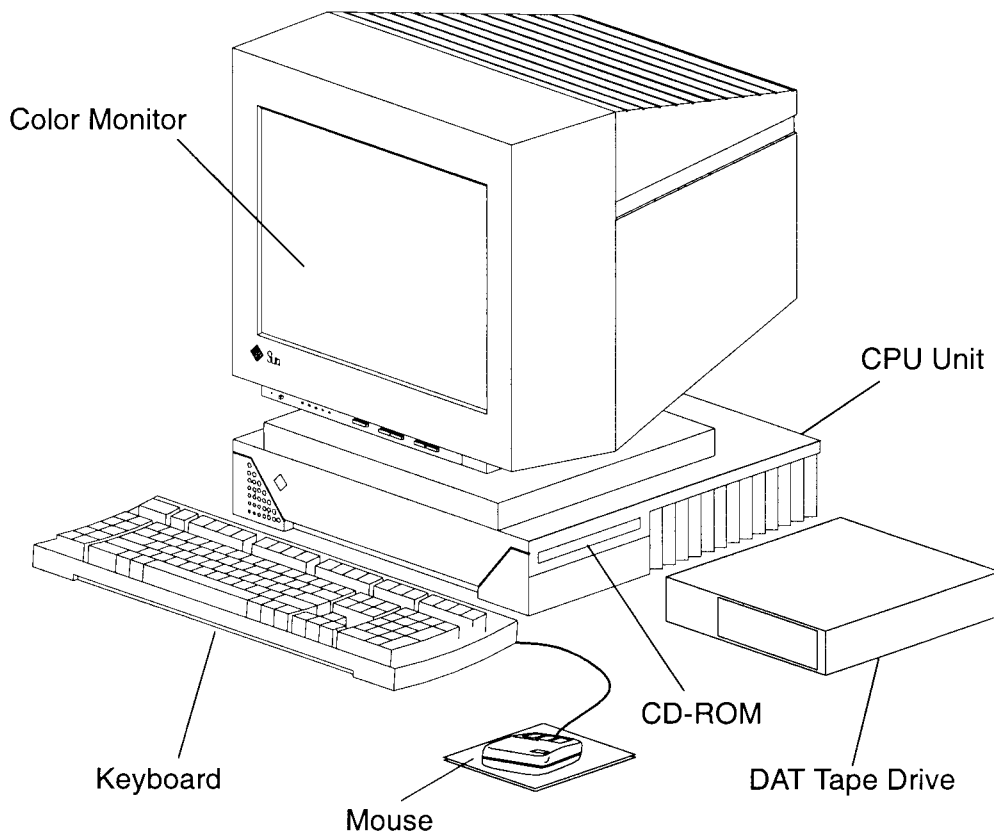

Reader Comment Form

Title: System Overview
(CRAY SV1™ Series Systems)

Number: 108-0196-003.1

Your feedback on this publication will help us provide better documentation in the future. Please take a moment to answer the few questions below.

For what purpose did you primarily use this document?

Troubleshooting Tutorial or introduction
 Reference information Classroom use
 Other - please explain

Using a scale from 1 (poor) to 10 (excellent), please rate this document on the following criteria and explain your ratings:

Accuracy _____
 Organization _____
 Readability _____
 Physical qualities (binding, printing, page layout) _____
 Amount of diagrams and photos _____
 Quality of diagrams and photos _____

Completeness (Check one and explain your answer)

Too much information Too little information Correct amount

You may write additional comments in the space below. Mail your comments to the address below, fax them to us at +1 715 726 4991, or e-mail them to us at ttd_online@cray.com. When possible, please give specific page and paragraph references. We will respond to your comments in writing within 48 hours.

NAME _____
JOB TITLE _____
E-MAIL ADDRESS _____
SITE/LOCATION _____
TELEPHONE _____
DATE _____

CRAY®

Technical Training and Documentation
900 Lowater Rd. P.O. Box 6000
Chippewa Falls, WI 54729
USA





