

CRAY J916™ DDI-10 Upgrade Procedure

HMU-185-0

Cray Research Proprietary

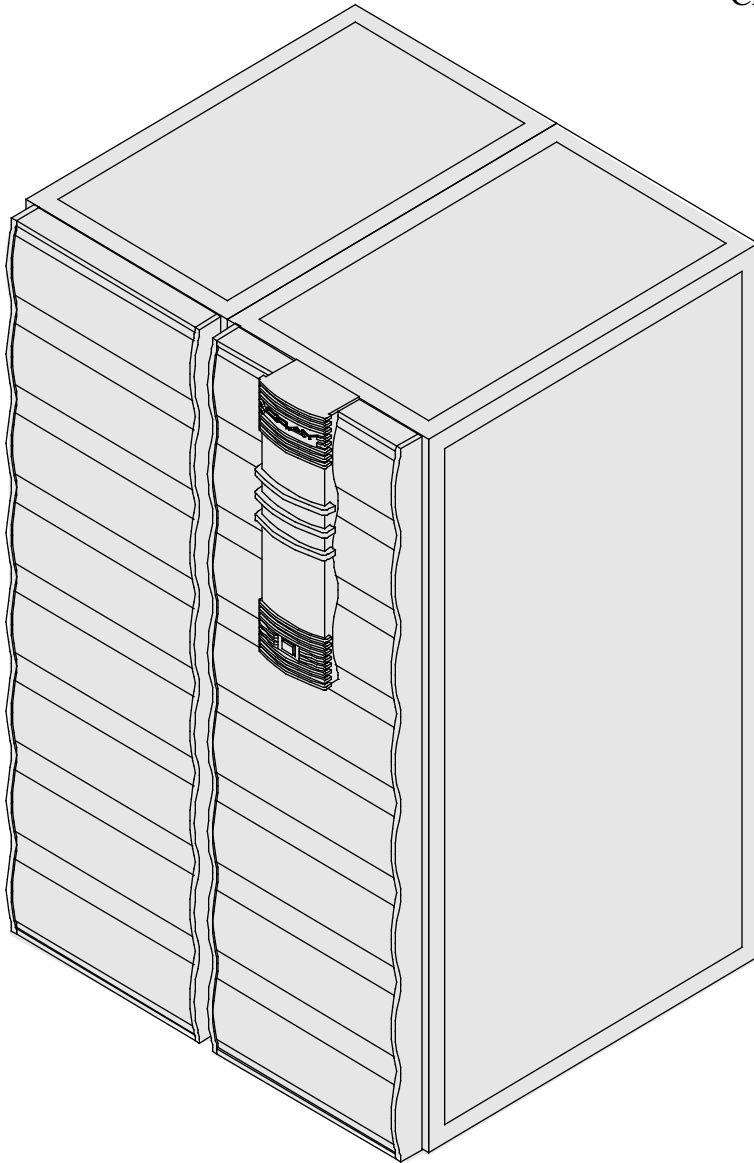

Cray Research, Inc.

Record of Revision

REVISION	DESCRIPTION
----------	-------------

	June 1995. Original distribution.
--	-----------------------------------

Any shipment to a country outside of the United States requires a letter of assurance from Cray Research, Inc.
--

This document is the property of Cray Research, Inc. The use of this document is subject to specific license rights extended by Cray Research, Inc. to the owner or lessee of a Cray Research, Inc. computer system or other licensed party according to the terms and conditions of the license and for no other purpose.

Cray Research, Inc. Unpublished Proprietary Information — All Rights Reserved.

Autotasking, CF77, CRAY, CRAY-1, Cray Ada, CraySoft, CRAY Y-MP, HSX, MPP Apprentice, SSD, UniChem, UNICOS, and X-MP EA are federally registered trademarks and Because no workstation is an island, CCI, CCMT, CF90, CFT, CFT2, CFT77, ConCurrent Maintenance Tools, COS, CRAY-2, Cray Animation Theater, CRAY C90, CRAY C90D, Cray C++ Compiling System, CrayDoc, CRAY EL, CRAY J90, Cray NQS, Cray/REELlibrarian, CRAY T3D, CRAY T90, CrayTutor, CRAY X-MP, CRAY XMS, CRInform, CRI/TurboKiva, CSIM, CVT, Delivering the power . . ., DGauss, Docview, EMDS, HEXAR, IOS, LibSci, ND Series Network Disk Array, Network Queuing Environment, Network Queuing Tools, OLNET, RQS, SEGLDR, SMARTE, SUPERCLUSTER, SUPERLINK, System Maintenance and Remote Testing Environment, Trusted UNICOS, and UNICOS MAX are trademarks of Cray Research, Inc.

Comments about this publication should be directed to:

CRAY RESEARCH, INC.
Hardware Publications and Training, hpt@pandora
890 Industrial Blvd.
Chippewa Falls, WI 54729

DDI-10 Upgrade Procedure

Overview	3
Device to Be Upgraded	3
Description of Upgrade	3
DDI-10 Upgrade Prerequisites	3
Training Requirements	4
ESD Precautions	4
ESD Smock	4
Wrist Strap	5
Reference Publications	5
Estimated Time to Install Upgrade	5
Parts Required	6
Tools Required	6
Software Required	6
Conventions	7
Getting Started	8
Create a Backup Copy of the UNICOS File System	8
Power Down the CRAY J916 System	8
Remove the I/O Cabinet Rear Door	9
Remove the I/O Cabinet Front Door	9
Gain Access to the Side of the I/O Cabinet	9
Install the PE-10I Slides	10
Install the PE-10I Tray	12
Install the DC-5I Controller	13
Make VME Bulkhead Plate Connections	15
Connect the Power, Control, and IPI Cables to the Rear of the PE Tray	16
Install Cable Retractor	16
Route Cables through Cable Retractor	17
Disconnect all Cables from VME Bulkhead	18
Route Cables through Cable Tray and Flexible Cable Way	20

Replace Side Panels or Push Cabinets Together	22
Replace Front I/O Door	22
Replace Rear I/O Door	22
Power Up the System	23
Edit the IOS Configuration File	23
Verify That the Upgraded Hardware is Functional	24
Software Configuration Preparation	26
IOS Information	26
Disk Configuration	27
Disk Configuration - Logical Definition	28
Software Change Procedure	30
Disk Device Integration	32
Removed Parts Disposition	32
IR Reporting	32

Figures

Figure 1. Clip Nut Locations on Chassis Rails	11
Figure 2. DC-5I Board Jumper Configurations for Controller 0	14
Figure 3. DC-5I JB2 Addressing	14
Figure 4. VME Bulkhead	15
Figure 5. J1 and J3 Connections	16
Figure 6. Cable Retractor	17
Figure 7. Flexible Cable Way	19
Figure 8. Flexible Cable Way Crossbars	20

Tables

Table 1. Estimated Time to Install Upgrade	5
Table 2. PE-10S Kit (P/N 90442300)	6

Overview

Device to Be Upgraded

This document contains procedures on how to add an intelligent peripheral interface (IPI) disk drive subsystem (DDI-10) to a CRAY J916 system.

Description of Upgrade

Cray Research customers have the option of adding additional disk storage to their CRAY J916 systems by upgrading the number of IPI peripheral trays (PE-10I) in their system. This procedure is written to aid CRI support personnel in the task of installing DDI-10 upgrades. You may want to check off each step of this procedure as you complete it.

The DDI-10 subsystem consists of a peripheral tray that includes the following components:

- Four IPI-2 disk drives
- Power supply
- DC-5I controller
- Cables

Following the instructions presented in this upgrade procedure provides the CRAY J916 system with added operational DDI-10 disks. The software upgrade procedure creates two TEMPORARY scratch file systems on these new disks. It is then the responsibility of the customer to integrate these disks into his or her existing CRAY J916 system disk configuration. The “[Disk Device Integration](#)” section, near the end of this document, provides some pointers to useful disk integration information.

DDI-10 Upgrade Prerequisites

The following list describes some special configuration considerations:

- It is recommended that the “[Software Configuration Preparation](#)” of this upgrade be completed prior to taking dedicated maintenance time on the system. This step involves configuring the new disks into temporary scratch file systems that can be completed while the system is in multiuser mode prior to the upgrade.

The customer may also want to prepare a production version UNICOS configuration (`param`) file prior to the upgrade in order to integrate these new disks into the existing CRAY J916 system disk configuration. This `param` file will then be available for the “[Disk Device Integration](#)” section of this upgrade.

- It is recommended that a full backup of existing file systems be completed before this upgrade is started.
- Procedures for integrating new disks with existing file systems are located in Section 5 of the *UNICOS Basic Administration Guide for CRAY J90 and CRAY EL Series*, Cray Research publication number SG-2416.

Training Requirements

Cray Research personnel who perform this backplane upgrade must have completed training in CRAY J916 hardware and system administration. If this is not possible, a hardware-trained person should have a system administrator available during this upgrade. Prior experience in upgrading or installing the UNICOS operating system on a CRAY J916 system or CRAY Y-MP EL system is advised.

ESD Precautions

Observe ESD precautions during the entire upgrade process. Required apparel includes an ESD smock and an ESD wrist strap. Do not wear watches or jewelry when you work on a CRAY J916 system cabinet.

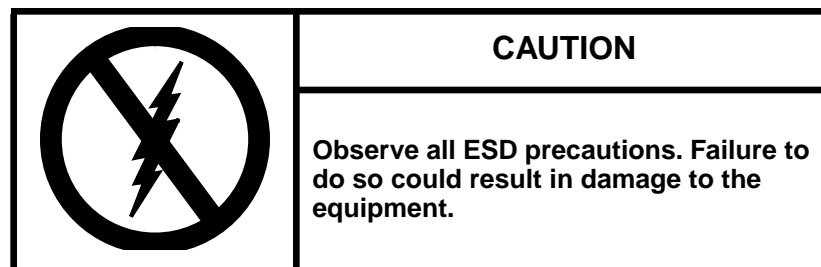

ESD Smock

Wear a Cray Research-approved static-dissipative smock when servicing or handling an ESD-sensitive device. Completely button the smock and wear it as the outermost layer of clothing. You must have a portion of the smock’s sleeves in direct contact with the skin of your arms. Skin contact is essential for a dissipative path-to-earth ground through your wrist strap. Tuck hair that exceeds shoulder length inside the back of the smock.

Wrist Strap

Wear a Cray Research-approved wrist strap when servicing or handling an ESD-sensitive device to eliminate possible ESD damage to equipment. Connect the wrist strap cord directly to earth ground.

Reference Publications

Refer to the following publications if you have questions when performing this upgrade:

- *UNICOS Basic Administration Guide for CRAY J90 and CRAY EL Series*, Cray Research publication number SG-2416
- *CRAY IOS-V Commands Reference Manual*, Cray Research publication number SR-2170
- *CRAY IOS-V Messages*, Cray Research publication number SQ-2172
- *Automated Confidence Testing*, Cray Research publication number HDM-110-0
- *CRAY J916 Service Manual Kit*, Cray Research publication number HMK-101-0
- *UNICOS Installation and Configuration Tool Reference Manual*, Cray Research publication number SR-3090

Estimated Time to Install Upgrade

[Table 1](#) divides the DDI-10 upgrade process into four separate procedures. Use this table to determine how much system time you should request to complete this upgrade.

NOTE: It is recommended that you contact the customer and request that he or she complete a full backup prior to this upgrade.

Table 1. Estimated Time to Install Upgrade

Install Task	Estimated Time to Install Upgrade
Hardware Install	4 hours
Hardware Verification Testing	1 hour
Software Configuration	1 hour
Software Verification Testing	1/2 hour

Parts Required

Table 2 lists the contents of the PE-10I kit (P/N 90442300).

Table 2. PE-10I Kit (P/N 90442300)

CRI Part Number	Quantity	Description
90257400	1	Module Assembly, DC-5I
90340700	1	Drive Tray Kit, PE-10I
90141400	8	Clip Nut, 1/4-20
90054600	6	Clip Nut, Captive 10-32
90141500	8	Screw, Sem Pan Head Phillips 1/4-20×1/2
90307200	1	Cable Carrier, Steel
90029200	2	Screw, Sem Pan Head Phillips 10-32×3/8
90307100	1	Power Cord, Universal 10 Amp
90266100	2	Terminator, Volt Mode, 50 Position, Standard
90307000	1	Harness Assembly, Control, External
90268100	2	Harness Assembly, DR-5I
90417600	2	Cable Assembly, IPI Intermediate, Non-shielded
90360700	2	Plate Assembly, 50-pin
90202400	2	Screwlock Kit, Female
90205301	1	Adhesive, Threadlock
90030502	10	Cable Tie, Mounting, Nylon, 8 inches
90154100	4	Screw, Truss Head Phillips 10-32×1/2SS
90030500	10	Cable Tie, Mounting, Nylon, 4 inches
90306600	1	Filter Assembly, Air
90441400	1	Shipping Container, J90 Disk Tray

Tools Required

Most of the tools required for performing upgrades are common hand-held tools that are included with the Customer Service toolkit. You may need a small hammer, which is not included in this toolkit.

Software Required

- Minimum IOS kernel revision - 1.3
- Minimum UNICOS revision - 8.0.3.2J
- No special considerations

Conventions

The following conventions are used throughout this document:

<u>Convention</u>	<u>Meaning</u>
command	This fixed-space font denotes literal items such as commands, files, routines, path names, signals, messages, and programming language structures.
manpage(<i>x</i>)	Man page section identifiers appear in parentheses after man page names.
<i>variable</i>	Italic typeface denotes variable entries, words or concepts being defined.
user input	This bold fixed-space font denotes literal items that the user enters in interactive sessions. Output is shown in nonbold, fixed-space font.
<KEY>	This convention indicates a key on the keyboard.

Getting Started

Create a Backup Copy of the UNICOS File System

It is recommended that you create a backup copy of the UNICOS file system before you proceed with the upgrade procedures. See the *UNICOS Basic Administration Guide for CRAY J90 and CRAY EL Series*, publication number SG-2416, for details on how to create a backup copy of the UNICOS file system.

Power Down the CRAY J916 System

1. Ensure that the customer has brought the system to single-user mode.
2. Using the right mouse button, click on any open working space. The Workspace menu will appear.
3. From the Workspace Menu, select the J90 Console menu item.

NOTE: You must have super user privileges to perform [Step 4](#).

4. Log into the UNICOS operating system by entering <CONTROL-a> to get a UNICOS prompt and enter the root login and password.
5. Shut down the UNICOS operating system by entering the following commands at a UNICOS prompt:

```
# cd /
# /etc/shutdown 120 (takes 120 seconds to execute)
# /bin/sync
# /bin/sync
# /bin/sync
# /etc/ldsync (if you are using ldcache)
```

6. Stop the J90 Console connection by entering the following commands:

```
# <CONTROL-a> (toggles to the IOS)
sn9xxx-ios0> mc
sn9xxx-ios0> reset (takes 30 – 45 seconds to execute)
BOOT[sn9xxx-ios0]> ~. <CONTROL-c>
```

7. Power off the system by pressing the CCU SYSTEM OFF button.

Remove the I/O Cabinet Rear Door

1. At the rear of the I/O cabinet, turn the two door fasteners 1/4-turn counterclockwise with a 5/32-in. allen wrench.
2. Grasp the door handle and swing the door open to the right.
3. Remove the screw that connects the green and yellow ground wire to the I/O cabinet.
4. Lift the door up about 1 in. (2.54 cm) and remove the I/O cabinet rear door from its hinges.

Remove the I/O Cabinet Front Door

1. At the front of the I/O cabinet, push down on the latch and swing the door open.
2. There is a cable that prevents the door from swinging back. Remove the retaining screw that attaches the ground wire cable to the I/O cabinet.
3. Lift up and remove the I/O cabinet front door from its hinges.

Gain Access to the Side of the I/O Cabinet

1. Remove the I/O cabinet side panel if only one I/O cabinet is located on each side of the mainframe cabinet.
 - a. Carefully pry the eight screw covers from the side panel using a very thin, strong pry or knife blade.
 - b. Loosen the eight captive screws that were revealed in the previous step.
 - c. Lift off the panel and set it aside.

If you have a system that includes two I/O cabinets on the same side, you will have to separate the cabinets if the upgrade is being installed into the inner cabinet. Use the following procedure to separate the cabinets.

1. Raise the levelers on the I/O and mainframe cabinets.
2. Remove the three frame-joining screws from the frame joiners on the I/O cabinet.
3. Separate and pull apart the cabinets.
4. Move the I/O cabinet so that the protruding flanges move back and away from the mainframe cabinet frame.
5. Insert the frame-joining screws on the I/O cabinet.

Install the PE-10I Slides

Install the PE-10I tray in the lowest available 3U (units) position. The “U” numbers are the numbers on the front of the I/O cabinet frame. These numbers will also be used to label the IPI cables attached to the rear of the PE tray. You must use the lowest position to prevent the cabinet from becoming top-heavy.

1. Remove the four screws from the filler plate that covers the empty position to be occupied by the new PE-10I tray. Additional filler plates may need to be removed if access space is desired for the upgrade. Retain the four screws to secure the new tray.
2. Place four large clip nuts (P/N 90141400) on each side of the cabinet (refer to [Figure 1](#)); there are eight clip nuts that will be used for installing the tray slides.
 - a. Place a clip nut into the 4th hole up from the clip nut of the last drive tray slide. Refer to [Figure 1](#).

NOTE: The following **exception** to the above step exists if you are installing a tray immediately above the VME chassis: You should insert the clip nut on the 7th hole up from the VME chassis slide.

- b. Install the upper clip nuts into the 5th hole above the lower clip nut. Refer to [Figure 1](#).
- c. **IMPORTANT!** Align each clip nut by centering it on the holes using a #2 Phillips screwdriver and inserting a screw in each clip nut before you install the slides.

NOTE: It may be necessary to use a small hammer to tap the clip nuts into place.

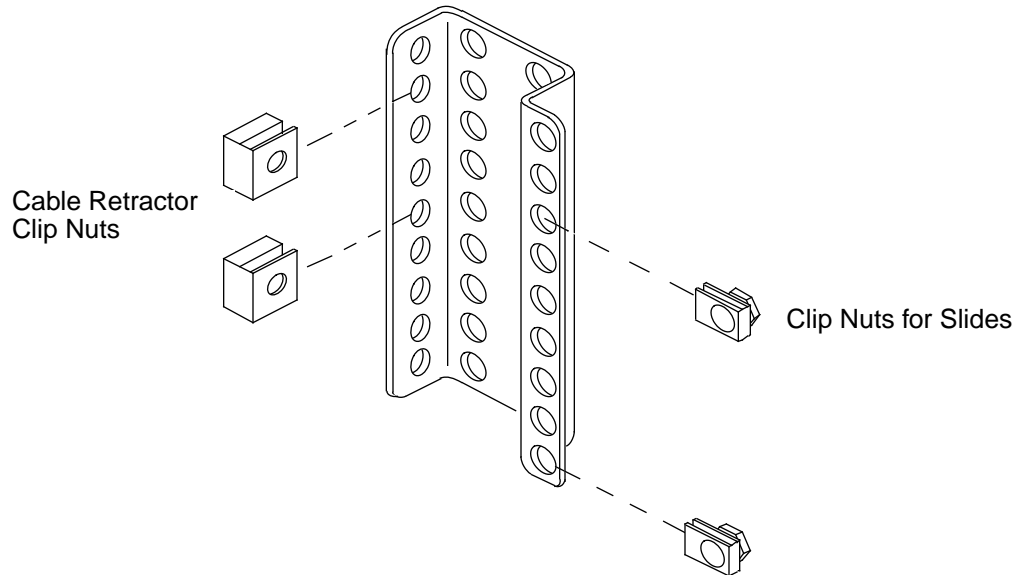

Figure 1. Clip Nut Locations on Chassis Rails

3. The back of the rail is the end with the rail stop. Place a slide against one side of the cabinet chassis over the clip nuts. Secure it with four 1/4-20 X 1/2 Phillips screws (P/N 90141500). Do not tighten these screws until all four screws have been started.

NOTE: Ensure that the slides are pushed up as far as possible to prevent interference with the tray located below the tray being installed.

4. Place the other slide on the other side of the cabinet and secure it with four Phillips screws.
5. Tighten all eight screws.

NOTE: The slides are greasy. You may want to wash your hands after working with the slides.

Install the PE-10I Tray

NOTE: The inside slides come installed on the PE tray.

CAUTION

Use two people to lift the PE-10I tray. If two people are not available, you should remove the individual disk drives from the tray to make the PE tray lighter. Failure to do so may cause a back injury or damage to components if the tray is dropped.

1. Extend the inner part of the slides.
2. Before installing the PE-10I into the system cabinet, ensure that all screws securing the top cover of the PE tray are tightened.
3. Slide the PE-10I onto the newly mounted slides in the I/O cabinet. You may have to slide the ballbearing section to the front to access the tray in order to slide onto the ballbearing section of the slides. You may also need to push up on the rail backstop.

NOTE: If the new tray interferes with the PE below, some adjustments of the rails will be necessary.

4. Install, on the front of the PE-10I tray, one of the screws that was removed from the cover plate to keep the tray in position while working at the rear of the cabinet.
5. Snap the air filter onto the front of the PE tray.

Install the DC-5I Controller

Insert the new DC-5I controller into the correct IOS, using the next available slot in that IOS. The position of this new controller depends on the customer's system configuration.

1. Pull out the VME chassis tray.
 - a. Remove the four screws that secure the IOS tray to the cabinet.
 - b. Pull out the VME tray as far as it will go.
 - c. Release the 14 1/4 captive screws that hold the top plate to the IOS tray.
 - d. Remove the top plate of the VME tray and set it aside.
2. Unpack the new controller board (P/N 90257400).
3. Place the new board on an ESD-protected surface.
4. Change any jumpers necessary on the new DC-5I controller board. Refer to [Figure 2](#) and [Figure 3](#).
5. Remove the VME slot filler.
6. Insert the new controller board into the guide slots in the IOS chassis and ensure that the board is completely seated.
7. Attach the male end of the DC-5I cables (P/N 90417600) to the front of the DC-5I controller. The port closest to the front of the VME is port 0, and the port closest to the back of the VME is port 1. Port 0 is physically connected to J2 at the back of the PE tray, and port 1 is connected to J4.

NOTE: Controller cables are labeled with the VME slot number (C1 through C20) and the port numbers (either 0 or 1); for example, C5 Port 0. These labels are located in the document holding tray just below the CPU card cage in the mainframe cabinet.

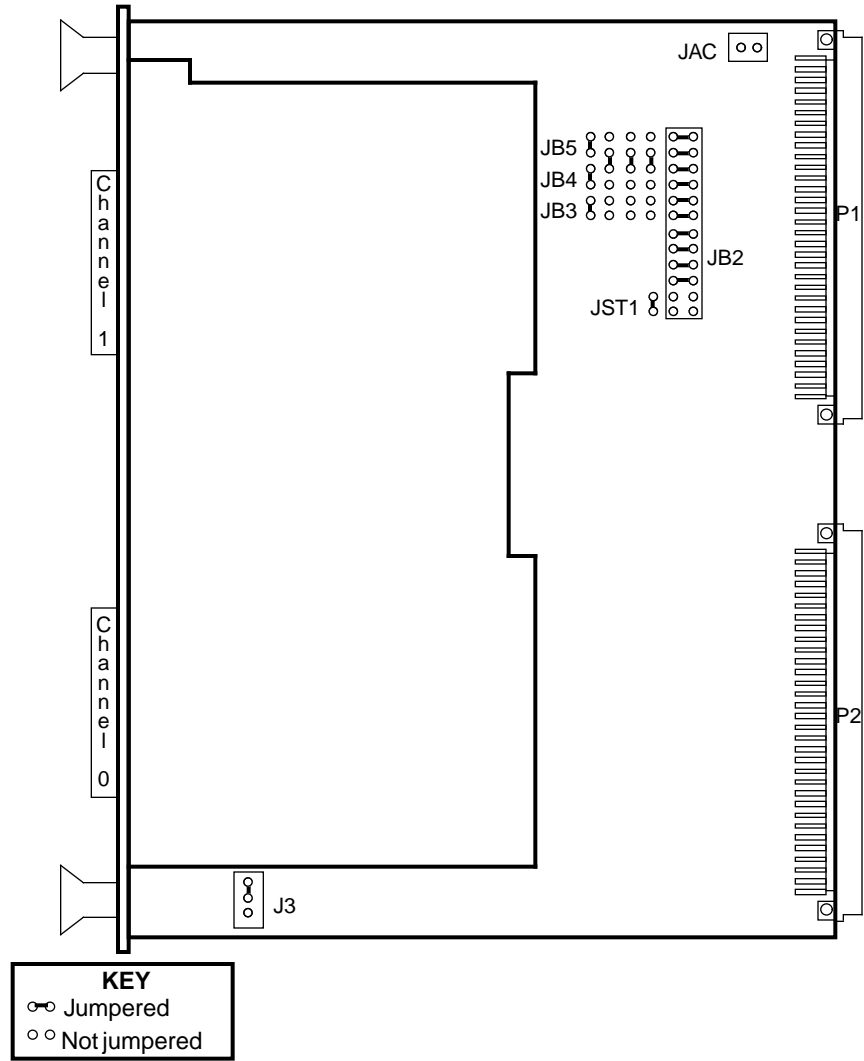

Figure 2. DC-5I Board Jumper Configurations for Controller 0

VME Controller	0	1	2	3
Address	C000	C100	C200	C300
JB2 Jumpering	—○	—○	—○	—○
	—○	—○	—○	—○
	—○	—○	—○	—○
	—○	—○	—○	—○
	—○	○ ○	—○	○ ○
	—○	—○	○ ○	○ ○
	—○	—○	—○	—○
	—○	—○	—○	—○
	—○	—○	—○	—○
	—○	—○	—○	—○
	○ ○	○ ○	○ ○	○ ○
	○ ○	○ ○	○ ○	○ ○

Figure 3. DC-5I JB2 Addressing

Make VME Bulkhead Plate Connections

NOTE: Try to use a location on the bulkhead that is in line with the newly installed controller card in the IOS to minimize the crossing of cables. Refer to [Figure 4](#).

1. Push the VME tray in and secure it with a single screw.
2. Push out the PE tray above the VME to gain better access.
3. Remove the two appropriate bulkhead plates that are each attached to the bulkhead by two screws.
4. Install the new plates (P/N 90360700) and secure them with the two screws removed from the blank plates.

NOTE: Ensure that the plate's gasket is positioned away from the metal mesh of the adjacent plate.

5. Attach the other end of the DC-5I cable to the VME bulkhead using two standoff screws (P/N 90202400) for each cable.

NOTE: Ensure that the standoff screws are seated into the bulkhead plate before you tighten them. As viewed from the back, port 0 is connected to the left of the port 1 connector. Orient the connector so that D points to the right.

6. Use a small amount of thread adhesive on the threads of each standoff screw.
7. Tighten the standoff screws lightly with a nut driver and ensure proper seating.

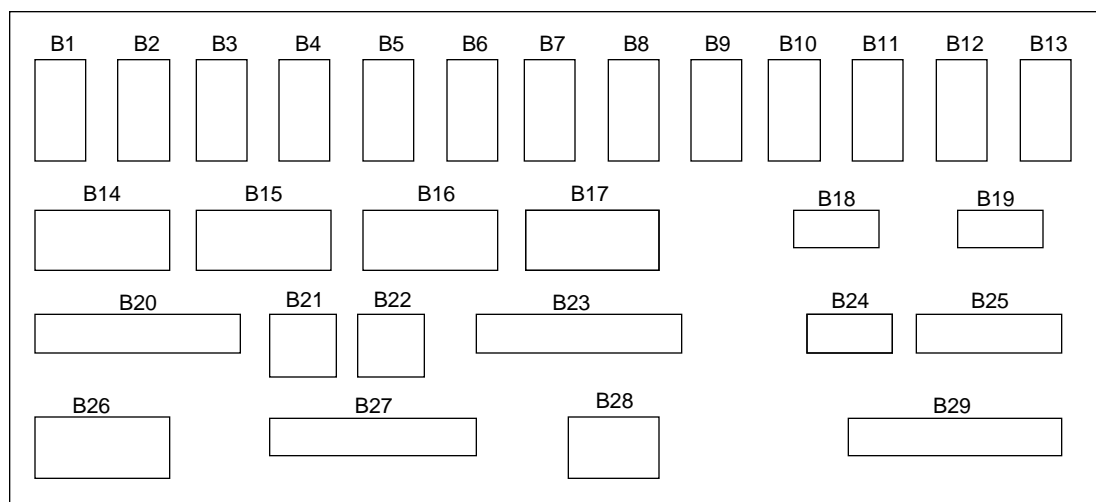

Figure 4. VME Bulkhead

Connect the Power, Control, and IPI Cables to the Rear of the PE Tray

1. Install the terminators (P/N 90266100) on the J1 and J3 connectors on the rear of the PE-10I tray. Refer to [Figure 5](#).

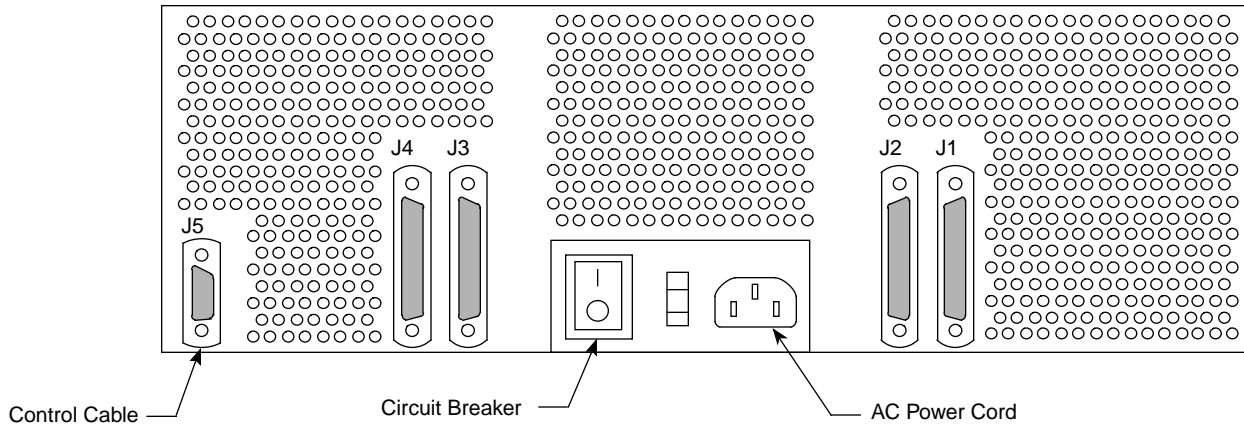

Figure 5. J1 and J3 Connections

2. Connect the power cable (P/N 90307100) into the power cord outlet on the rear of the PE-10I tray. Refer to [Figure 5](#).
3. Connect the control cable (P/N 90307000) into connector J5. Refer to [Figure 5](#).
4. Connect the IPI cables (P/N 90268100) into connectors J2 and J4. Refer to [Figure 5](#).
5. Label the ends of the IPI cables with the J designator (J2 or J4) on the end connected to the PE tray. Also attach a label (U designator) to each cable to designate the drawer start. The B VME bulkhead designator is placed on the other end. J2 connects to DC-5I port 0, and J4 connects to DC-5I port 1 at the VME bulkhead.

Install Cable Retractor

Refer to [Figure 6](#) for an illustration of the cable retractor (P/N 90307200).

1. At the rear of the cabinet on the left side, install small clip nuts in the 5th and 8th holes up from the previous tray or on the 6th and 9th holes up from the previous cable retractor.

NOTE: In order to have easier access, it may be necessary to unplug a cable from the power and distribution rail.

2. Install the cable retractor arm on the clip nuts using two Phillips screws inserted into the top and bottom holes of the cable retractor.

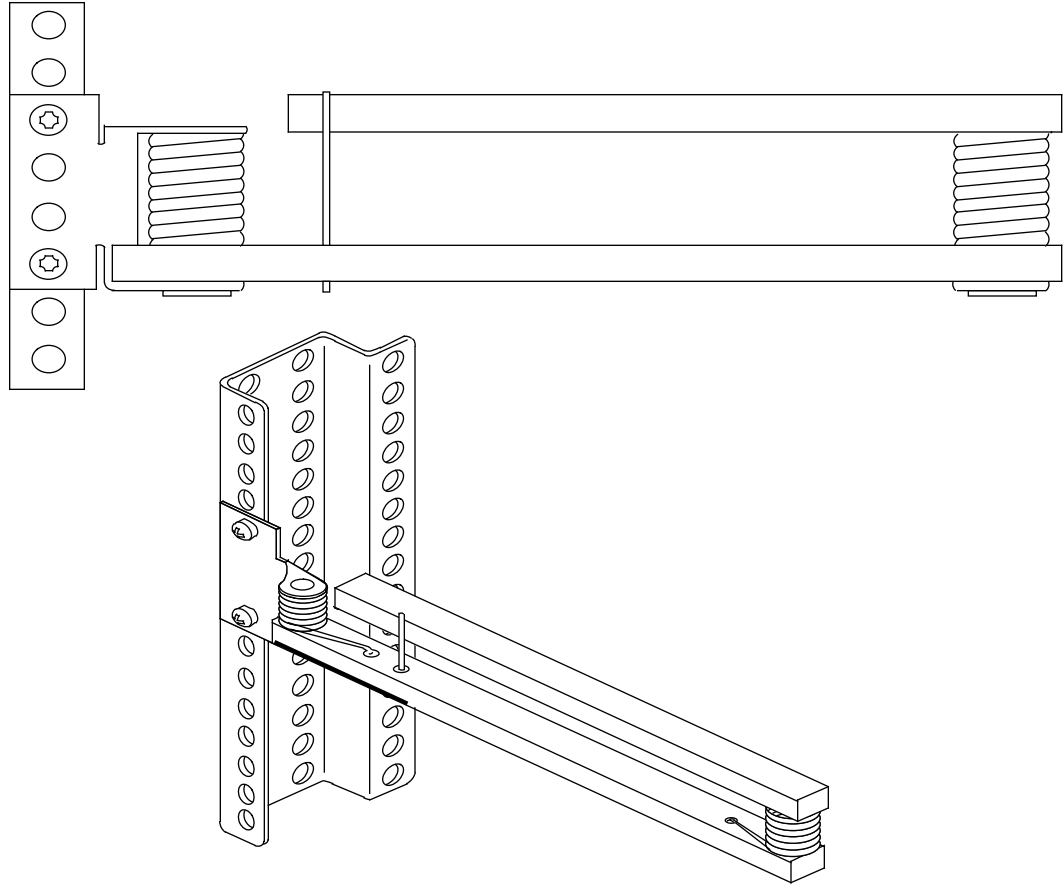

Figure 6. Cable Retractor

Route Cables through Cable Retractor

If you are installing a PE tray in the lower units of an I/O cabinet, it may be necessary to remove the I/O bulkhead. Refer to the [CRAY J916 Service Manual Kit](#), Cray Research publication number HMK-101-0, for procedures on how to remove and replace the bulkhead.

1. Remove the single retaining screw and extend the new PE-10I tray about 6 inches (15.2 cm).
2. The following list describes the suggested slack for the cables.
 - J2 is 14 inches (35.6 cm)
 - J4 is 9 inches (22.9 cm)
 - Power connection is 12 inches (30.5 cm)
 - Remote alarm cable is 7 inches (17.8 cm) (J5 at back of PE-10I)

3. Route the power, control, and IPI cables from the rear of the new PE-10I tray through the cable retractor. Ensure that there is adequate slack between the cable retractor and the drive connection to allow the tray to be fully extended.
4. Loosely install, but do not tighten, three tie wraps (P/N 90030502) on each side of the cable retractor to keep the cables in place and to allow for adjustments of cable end lengths later.
5. Connect the power cable to the most convenient outlet on the power and control distribution rail.
6. Connect the control cable to the most convenient 9db connectors on the power and control distribution rail.
7. The power and control cables need to be folded back on the cable retractor to take up any excess slack. Use cable ties and the holes in the cable retractor to secure the power and control cables.
8. Adjust and tighten the tie wraps.

Disconnect all Cables from VME Bulkhead

1. Disconnect all cables from the VME bulkhead that are routed through one or both of the two flexible cable ways.

NOTE: Whether one or both of the flexible cable ways are disconnected depends on the number of cables being routed and where the cables will be attached on the VME bulkhead.

2. Disconnect the flexible cable ways by removing the two screws that secure them to the VME tray. Refer to [Figure 7](#).
3. Lay the cable ways flat.
4. Loosen the two 1/4-turn screws at the front of the I/O cabinet just below the VME tray.
5. Remove the single screw from the front of the VME.
6. Extend the VME tray completely.
7. Remove the cable tray cover by sliding the cover out through the front of the I/O cabinet and set it aside.

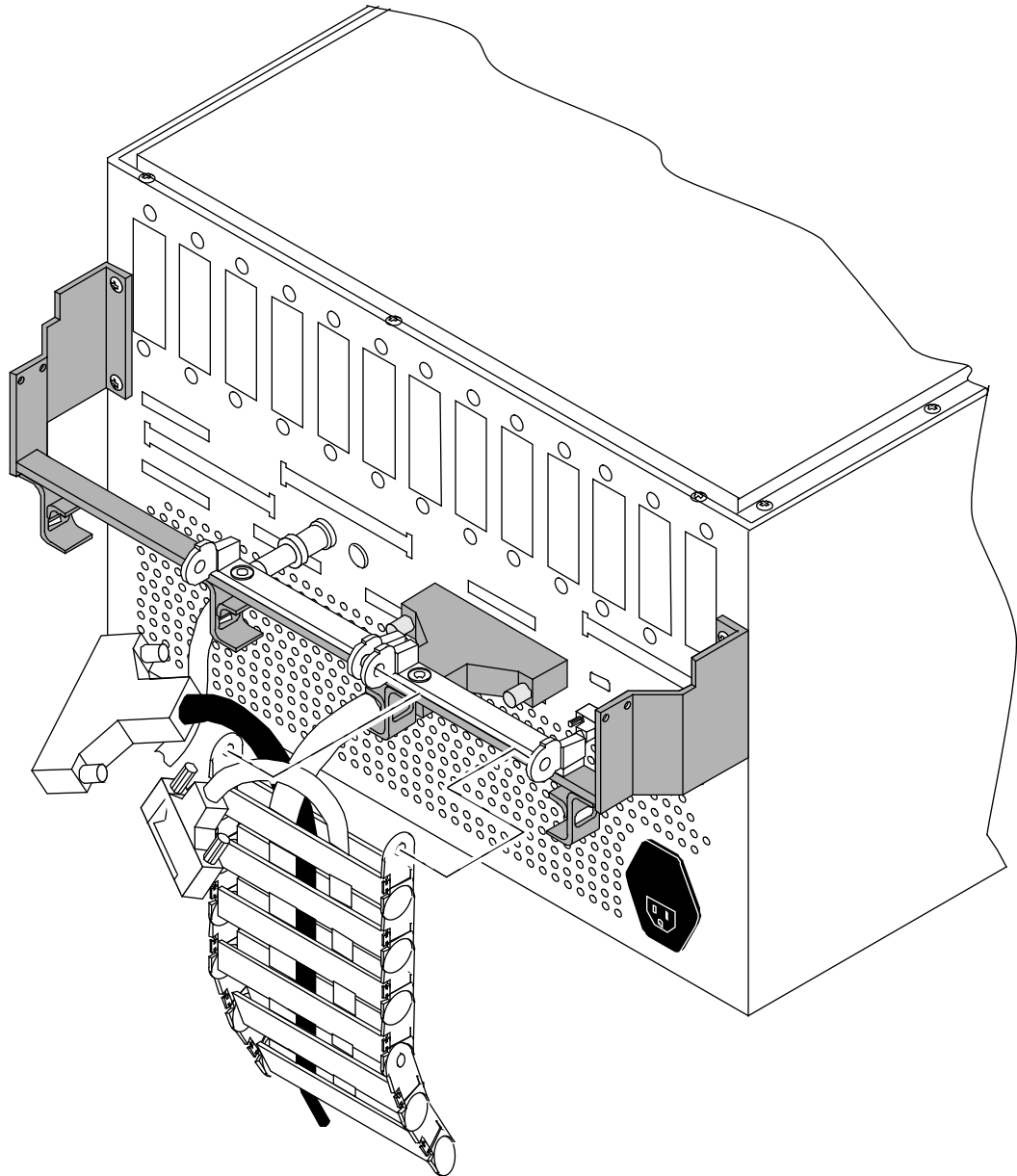

Figure 7. Flexible Cable Way

NOTE: If the DDI-10 cables will be routed through only one of the two flexible cable ways, only the crossbars for that flexible cable way need to be opened. If cables will be routed through both of the flexible cable ways, both crossbars will have to be opened.

8. Pry open each crossbar of the cable way, using a standard 1/8-in flat-bladed screwdriver and leave the inner side attached. Refer to [Figure 8](#).

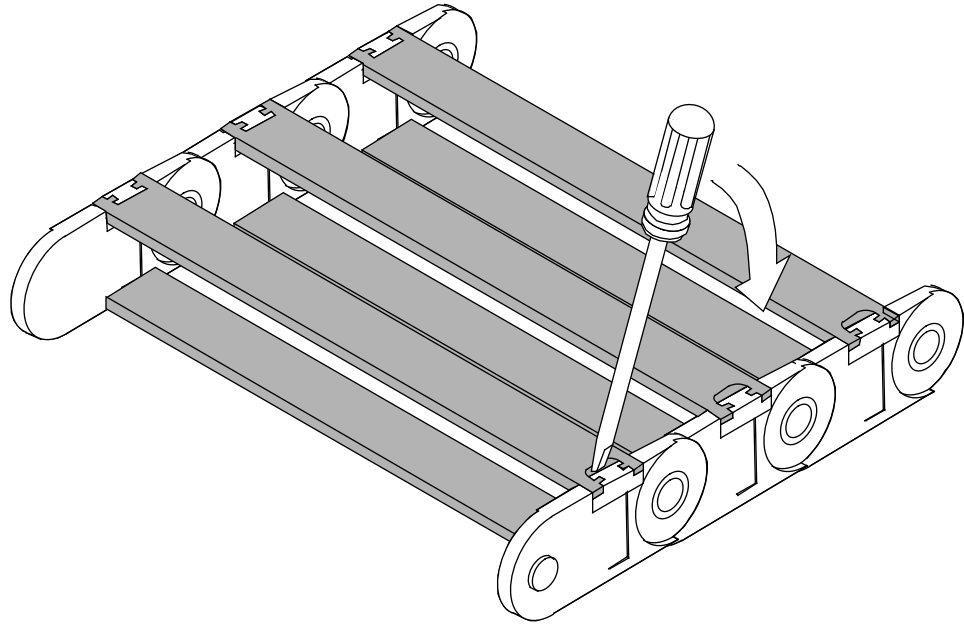

Figure 8. Flexible Cable Way Crossbars

Route Cables through Cable Tray and Flexible Cable Way

1. Route the IPI cables down or up the side of the I/O cabinet next to the power and control distribution rail and secure them with tie wraps.
2. Place the IPI cables in the flexible cable way and in the cable-routing tray beginning with the lowest tray installed with this upgrade. Ensure that the cables do not cross in the flexible cable way because this will make adjusting the cables more difficult.
3. After the cables have been routed, loosely secure the IPI cables with tie wraps.
4. Snap down all crossbars for the flexible cable way. (This is not easy!) Then, ensure that both ends of each crossbar are secure.
5. Slide the VME tray into the cabinet carefully and secure it with one screw.

CAUTION

Do not pinch the cables when sliding in the VME tray or the cable cover.

NOTE: Y1, power, and control cables are routed below the VME flexible cable-way attachment bar.

6. Reconnect the flexible cable way using the two screws originally removed from the flexible cable-way bar. Refer to [Figure 7](#).
7. Reattach the Y1 cables to the VME bulkhead.
8. Reattach the rest of the cables to the VME bulkhead using cable and bulkhead labels.
9. Remove the single retaining screw and extend the VME tray out until the tray slides lock.
10. Adjust the cables inside the cable tray and flexible cable way if there is excess slack at the VME bulkhead.
11. Tighten all tie wraps.
12. Reinstall the cable tray cover by sliding it carefully in and over the cable tray from the front of the I/O cabinet.
13. Secure the cable tray cover at the front of the I/O cabinet with two 1/4-turn screws.
14. Install the VME cover.
15. Slide the VME tray in.
16. Install the four screws in the front of the VME tray.
17. Install the remaining screws in the front of the PE-10I.
18. Turn on the power switches on the front and the rear of the PE-10I tray.

Replace Side Panels or Push Cabinets Together

1. Replace the side panels.
 - a. Place the side panel into the recess on the side of the cabinet.
 - b. Tighten the eight captive screws.
 - c. Replace the eight screw covers.

OR

1. Remove the three frame-joining screws from the frame joiners on the I/O cabinet.
2. Connect the cabinets.
 - a. Move the I/O cabinet so that the protruding flanges hook over the mainframe cabinet frame.
 - b. Insert and tighten the three I/O cabinet bracket screws that connect the cabinets.
 - c. Adjust the physical location of the cabinets, if necessary.
3. Lower the levelers on all cabinets so that the weight of each cabinet is distributed evenly.

Replace Front I/O Door

1. Place the door on its hinge pins.
2. Reattach the front door's cable wire to the I/O chassis.
3. Close the door.

Replace Rear I/O Door

1. Place the door onto the two hinge pins.
2. Reattach the green and yellow ground wire to the I/O cabinet.
3. Swing the door shut.
4. Turn the fasteners clockwise with a 5/32-in. allen wrench until the two circle symbols meet and the fastener is latched.

Power Up the System

NOTE: If the J90 Console window is already up, skip to [Step 3](#).

1. Using the right mouse button, click on any open working space. The Workspace menu will appear.
2. Select the J90 Console menu item.
3. Move the circuit breaker on the back of the I/O cabinet to the ON position first, and then move the circuit breaker on the mainframe cabinet to the ON position.
4. Press the Alarm Acknowledge button on the CCU.
5. Press the CPU RESET button on the CCU.
6. Press the VME RESET button on the CCU.
7. Verify that the SYSTEM READY light on the control panel illuminates.
8. Close the mainframe front door.
9. Watch the J90 console window to ensure that the system powers up correctly. If the `/diag/scripts/powerup` script exists on the IOS's file system, then this script will execute to test the IOBB. If no errors exist, the only output from this diagnostic is the message `Powerup IOBB test in progress`. You should see the `BOOT[sn9xxx-ios0]` prompt when power-up is complete.

Edit the IOS Configuration File

Open an xterm window on the system console and use the `vi` command to update the `/opt/ios/9xxx/config` file. The IOS definition section of `config`, which corresponds to the IOS that is receiving the new disk hardware, should contain the following entries:

Entry name	Entry definition
<code>/dev/disk</code>	The disk strategy module
<code>/dev/dc5i</code>	IPI disk driver module

These are permanent additions. These entries may already exist in the given IOS section if that IOS already contains hardware that uses one or more of these modules. Each of these entries should be listed only once in an IOS definition section of the `config` file, but they should be listed in every IOS definition section that relates to an IOS receiving these disks.

Verify That the Upgraded Hardware is Functional

1. Load the IOS kernel by entering the following command (this step takes 3 to 30 minutes:

```
BOOT[sn9xxx-ios0]> load
```

2. Confirm that the new disks and controllers are correctly recognized in the output of the IOS `load` command. The following example is a partial sample of output for a DDI-10 subsystem:

```
DC5I ctlr 0    unit 0 [b00], type = DD5I  VME64 mode
DC5I ctlr 0    unit 1 [b01], type = DD5I  VME64 mode
DC5I ctlr 0    unit 2 [b02], type = DD5I  VME64 mode
DC5I ctlr 0    unit 3 [b03], type = DD5I  VME64 mode
```

The information in the `[bxy]` notation is used in Steps 6, 7, and 8. The `x` refers to the controller number within an IOS (0 in this example, corresponding to `eiop 30`). The `y` refers to unit or device number (0, 1, 2, and 3 in this example).

If all the new disks and controllers are not recognized, verify that the IOS configuration file was properly edited. If that file looks correct, verify that the hardware was properly installed by completing the following tasks:

- Verify that the amber error LED on the new disk controller is not illuminated.
- Examine all cable connections and terminators to make sure they are functional.
- Examine all terminator pins to ensure that they are straight.
- Verify that both the front and rear power enable switches on the new PE tray are enabled.

3. The `bldact` IOS command, which you will be instructed to execute in [Step 4](#), will prompt you for information about which Y1 channels are attached to each IOS. Make note of this channel information by viewing the `/sys/param` file before running the `bldact` command. The following type of line, which tells which Y1 channel (`channel 020`) is connected to which IOS (`cluster 0`), is in the `HARDWARE INFORMATION` section of the `/sys/param` file:

```
channel 020 is lowspeed to cluster 0;
```

4. Enter the `bldact` IOS command. This will update the `ACT frstload` script (`/diag/scripts/frstload`) as necessary with one call to the `dd5iql` diagnostic in each section of the script that relates to an IOS that contains DD-5I disk drives. The `bldact` command should take less than 1 minute to complete. The following is sample output:

```
sn9xxx-ios0> bldact
Build Automated Confidence Test script file, IOS-V version.
File /diag/scripts/frstload.
Is Y1 input channel 20 cabled to IOS 0? (y)es, (n)o: y
sn9xxx-ios0>
```

5. After the `bldact` script has completed, execute the newly created `frstload` script by hand to ensure it functions correctly. This will take several minutes to execute (the length of execution depends on the number and type of peripherals on the system). Execute the `frstload` script as follows:

```
sn9xxx-ios0> /diag/scripts/frstload
```

6. Run the `dd5itest` diagnostic on each IOS that has new DD-5I disks installed. The `dd5itest` diagnostic will prompt you for a controller number. The controller number is the value you noted in [Step 2](#). Run test number 99 on each new drive to ensure that all possible tests are executed on each new drive. This will take about 5 minutes per drive.
7. Optional step: Do a surface analysis of the disk by entering the `dsurf` command. Use the output from the `load` command ([Step 2](#)) to get the correct device names for use on the `dsurf` command line (the disk type designator on the `dsurf` command line is `b` for DD-5I drives). This command will take approximately 30 minutes per drive to complete. For example:

```
sn9xxx-ios0> dsurf b02 -v1 1
```

8. Enter the following command once for each new drive to make a backup copy of the flaw table for each new drive. Use the output from the `load` command ([Step 2](#)) to get the correct device names for use on the `dflawr` command line:

```
sn9xxx-ios0> dflawr b00
```

Software Configuration Preparation

This section may be completed prior to taking dedicated maintenance time on the system. If you have already completed this section, continue with the [“Software Change Procedure”](#) section.

Update and verify the UNICOS configuration file. Save a copy of the original version by entering the following commands:

```
sn9xxx-ios0> cd /sys
sn9xxx-ios0> cp param param.disk
```

The changes you will be making in the following [“IOS Information”](#) section should be considered permanent. Portions of the [“Disk Configuration”](#) section will reflect the temporary scratch file systems created in this upgrade procedure.

NOTE: The customer must integrate these disks into the existing CRAY J916 system disk configuration following completion of these upgrade procedures.

On the system console, use the `vi` command to update the `/opt/ios/9xxx/sys/param.disk` file with the new disk information. Ensure that you update all appropriate information in the following subsections.

IOS Information

Note the IOP (cluster) where the DC-5I controller has been installed. Add the appropriate `eiop` value to the `cluster` definition statement for that IOP.

The first physical DC-5I disk controller board on an IOS will be assigned the `eiop` value of 30. The second physical DC-5I disk controller board on that same IOS will be assigned the `eiop` value of 31. (All four disks in a DDI-10 subsystem are controlled by a single DC-5I controller. Therefore, only one `eiop` value should be added to the cluster for each DDI-10 subsystem.)

Disk Configuration

If you need more information on disk configuration syntax, refer to the *UNICOS Basic Administration Guide for CRAY J90 and CRAY EL Series*, publication number SG-2416.

Add the appropriate information to define the new physical device configuration.

1. Specify the `cluster` (IOS) and `eiop` (logical controller) numbers. These are the same values chosen in the preceding “[IOS Information](#)” subsection.
2. Specify the `channel` using the Y1 channel value (in octal) that corresponds with the specified IOP cluster.
3. Specify the `type` parameter to be `DD5I` for DD-5I drives (DDI-10).
4. The `unit` parameter will either be 0, 1, 2, or 3 signifying the four disk drives that are attached to that `eiop` (logical controller) number.
5. The capacity of each DD-5I drive is 723,000 sectors (1 sector = 4096 bytes).

You must use system-wide unique names and minor numbers for each physical device definition (`pdd`) statement for the new disks. Do not use existing names or `pdd` minor numbers. The name of the disk itself also must be unique throughout the entire UNICOS configuration file.

The following example shows possible physical device definition statements for one DDI-10 (four DD-5Is):

```
disk B_1300 {type DD5I; iopath {cluster 1; eiop 30; channel 040;} unit 0;
  pdd scratch_a0 {minor 26; sector 0; length 500000 sectors;}
  pdd scratch_b0 {minor 27; sector 500000; length 223000 sectors;}
}
disk B_1301 {type DD5I; iopath {cluster 1; eiop 30; channel 040;} unit 1;
  pdd scratch_a1 {minor 28; sector 0; length 723000 sectors;}
}
disk B_1302 {type DD5I; iopath {cluster 1; eiop 30; channel 040;} unit 2;
  pdd scratch_b2 {minor 29; sector 0; length 723000 sectors;}
}
disk B_1303 {type DD5I; iopath {cluster 1; eiop 30; channel 040;} unit 3;
  pdd scratch_b3 {minor 30; sector 0; length 723000 sectors;}
}
```

Disk Configuration - Logical Definition

Add the appropriate information to define the logical devices that relate to the new physical devices.

1. You must use system-wide unique names and minor numbers for each logical device definition (ldd) statement relating to the new disks. You cannot use existing names or ldd minor numbers.
2. Following are possible logical device definitions for the temporary scratch file systems created in this upgrade procedure:

```
ldd scratcha {
  minor 20;
  pdd scratch_a0;
  pdd scratch_a1;
}
ldd scratchb {
  minor 21;
  pdd scratch_b0;
  pdd scratch_b2;
  pdd scratch_b3;
}
```

3. The values for PDDMAX, PDDSLMAX, and LDDMAX may require adjustment. Refer to the *UNICOS Basic Administration Guide for CRAY J90 and CRAY EL Series*, publication number SG-2416, for more information.

PDDMAX represents the maximum number of physical disks allowed. Physical disks are the `disk` entries in the `param` file. PDDMAX should be at least equal to the number of configured physical disk devices.

PDDSLMAX represents the maximum number of physical slices allowed. Physical slices are the `pdd` definitions in the `param` file. PDDSLMAX should be set to at least one more than the highest minor number used by a `pdd` statement in the `param` file. (PDDSLMAX is used to calculate the size of a kernel table, and the minor numbers are used to index into that table.) A value of at least 256 is recommended for PDDSLMAX. This is needed for the correct operation of the `pddconf(8)` command.

LDDMAX represents the maximum number of logical devices allowed. Logical devices are the `ldd` definitions in the `param` file (and the devices created in the directory `/dev/dsk`). LDDMAX should be set at least one higher than the highest minor number used by an `ldd` statement in the `param` file. (LDDMAX is used to calculate the size of a kernel table, and the minor numbers are used to index into that table.)

Validate your changes to the `param` file by performing the following steps:

1. UNICOS must now be in single-user or multiuser mode. If UNICOS has not been booted, boot to single-user mode now by entering the following command:

```
sn9xxx-ios0> /bin/boot
```

2. On UNICOS, copy the `param.disk` file from the SPARC console's file system to a UNICOS file, such as `/param_test`, as follows:

```
# exdf -i /sys/param.disk > /param_test
```

3. To validate the syntax of your `param` file changes, enter the following command:

```
# /etc/econfig /param_test
```

If the `econfig` command detects a problem with your configuration file, you must correct that problem **before** continuing with the next step. It also is worthwhile to manually review the changes made to the `param_test` file at this time, to make sure you have not made any logical errors.

If changes are made to the `param_test` file while validating it under UNICOS, copy the changed version back to the system console before proceeding by entering the following command:

```
# exdf -ro /sys/param.disk < /param_test
```

- Return to the IOS prompt (if not already there), and make a backup copy of the existing `param` file, and then replace it with the newly created version of the `param` file. Enter the following commands:

```
# <CONTROL-a> (toggles to the IOS console if in single user mode)
sn9xxx-ios0>
sn9xxx-ios0> cd /sys
sn9xxx-ios0> cp param param.bak
sn9xxx-ios0> cp param.disk param
```

This is the end of the “[Software Configuration Preparation](#)” section.

Software Change Procedure

- Boot UNICOS to single-user mode, with the new `param` file, by entering the following command:

```
sn9xxx-ios0> /bin/boot
```

- On UNICOS, use the `exdf` command to copy the `param` file from the SPARC console’s file system to a UNICOS file, such as `/param_test`:

```
# exdf -i /sys/param > /param_test
```

- Create the device nodes for the new disk configuration by entering the following UNICOS commands:

```
# /bin/mv /dev/mkdev.sh /dev/mkdev.sh.bak
# /etc/econfig -d /param_test > /dev/mkdev.sh
# chmod 700 /dev/mkdev.sh
# cd /dev
# rm -f dsk/* pdd/* mdd/* sdd/* ldd/*
# /dev/mkdev.sh
```

- Create the two new temporary scratch file systems by entering the following commands:

```
# /etc/mkfs -q /dev/dsk/scratcha
# /etc/mkfs -q /dev/dsk/scratchb
```

5. Verify the two new temporary scratch file systems by entering the following commands:

```
# /etc/fsck /dev/dsk/scratcha
# /etc/fsck /dev/dsk/scratchb
```

6. If you are running MLS, use the `/etc/labelit` command to label the file systems appropriately.
7. Ensure that you can mount the two new scratch file systems by entering the following commands:

```
# /bin/mkdir /scratcha ; chmod 755 /scratcha
# /etc/mount /dev/dsk/scratcha /scratcha
```

```
# /bin/mkdir /scratchb ; chmod 755 /scratchb
# /etc/mount /dev/dsk/scratchb /scratchb
```

8. To verify that the upgrade was successful, copy data to the scratch file systems by entering the following commands:

```
# cp /unicos /scratcha/uni1
# cp /unicos /scratcha/uni2
# cp /unicos /scratchb/uni3
# cp /unicos /scratchb/uni4
# cp /unicos /scratchb/uni5
```

Verify that each file is the proper size; then remove these files.

9. Unmount all file systems by entering the following command:

```
# /etc/umountem
```

10. The system can now be booted to multiuser mode or the customer may proceed to the “[Disk Device Integration](#)” section. Enter multiuser mode by entering the following command:

```
# /etc/init 2
```

Disk Device Integration

Now that it has been verified that the DDI-10 upgrade has been successful, it is necessary for the customer to integrate these new disks with existing file systems. This requires further editing of the `param` file: the file that was previously edited in this upgrade to create the scratch file systems.

Refer to the *UNICOS Basic Administration Guide for CRAY J90 and CRAY EL Series*, publication number SG-2416, for details. The procedure pages in the File Systems section of that manual describe the necessary steps. The alterations are described both with and without the use of the UNICOS Installation / Configuration Menu System (ICMS). The change procedures outlined in this upgrade document can be used to supplement SG-2416.

NOTE: Create backup copies of any file systems that will be changed in the UNICOS configuration file (`param`).

The changes made to the IOS configuration file and some changes made to the UNICOS configuration file (`param`) in the “[Software Configuration Preparation](#)” section should be retained. These include the addition of `eiop` values to the IOS cluster definition and any changes to `PDDSLMAX`, `LDDMAX`, and `PDDMAX` in the UNICOS definition section.

If the UNICOS dump device (called logical device dump in the `param` file) will be moved to one of the new disks, then edit the `/opt/ios/9xx/sys/mfdumpa.arg` file on the system console to reflect this new location. In the `mfdumpa.arg` file, set the `disktype` keyword to be `DD5I`.

Removed Parts Disposition

Do not dispose of removed parts locally; return the removed parts to:

Cray Research, Inc.
1000 Halbleib Road
Chippewa Falls, WI 54729
Attention: Removed Equipment Management

IR Reporting

There is a separate incident report for upgrades. Refer to [CSH # ADM-COM-9307](#). Please fill one out.