



ADVANCE COPY

CRAY-1 COMPUTER SYSTEM

BLOCK DIAGRAMS

FOR THE

CRAY-1 COMPUTER

(CONTENTS: PARTIAL SET - PRELIMINARY DIAGRAMS)

INTERNAL USE ONLY

ADVANCE COPY
CRAY-1 COMPUTER SYSTEM
BLOCK DIAGRAMS
FOR THE
CRAY-1 COMPUTER
(CONTENTS: PARTIAL SET - PRELIMINARY DIAGRAMS)
INTERNAL USE ONLY

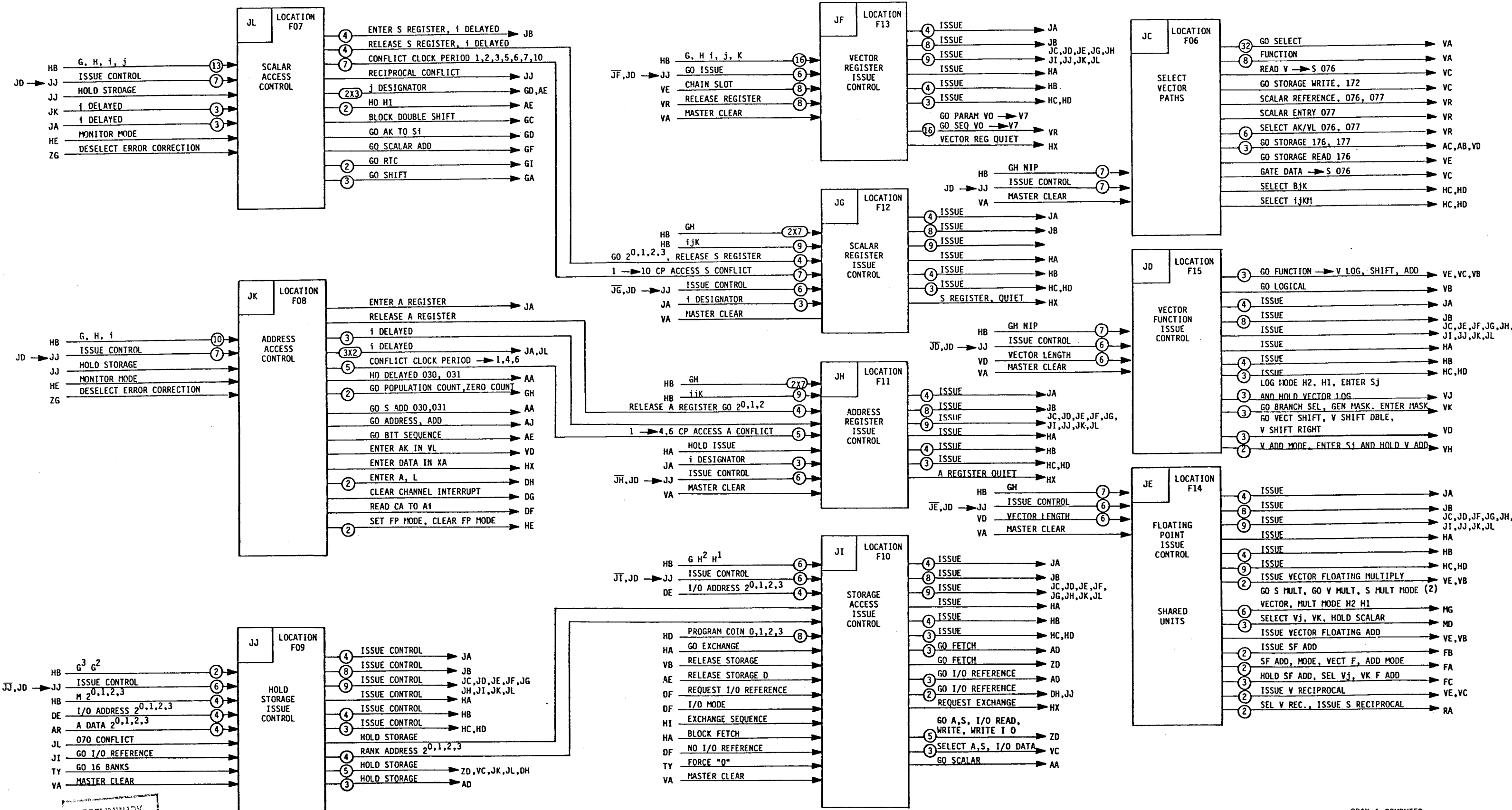

PRELIMINARY
INFORMATION

PRELIMINARY
INFORMATION

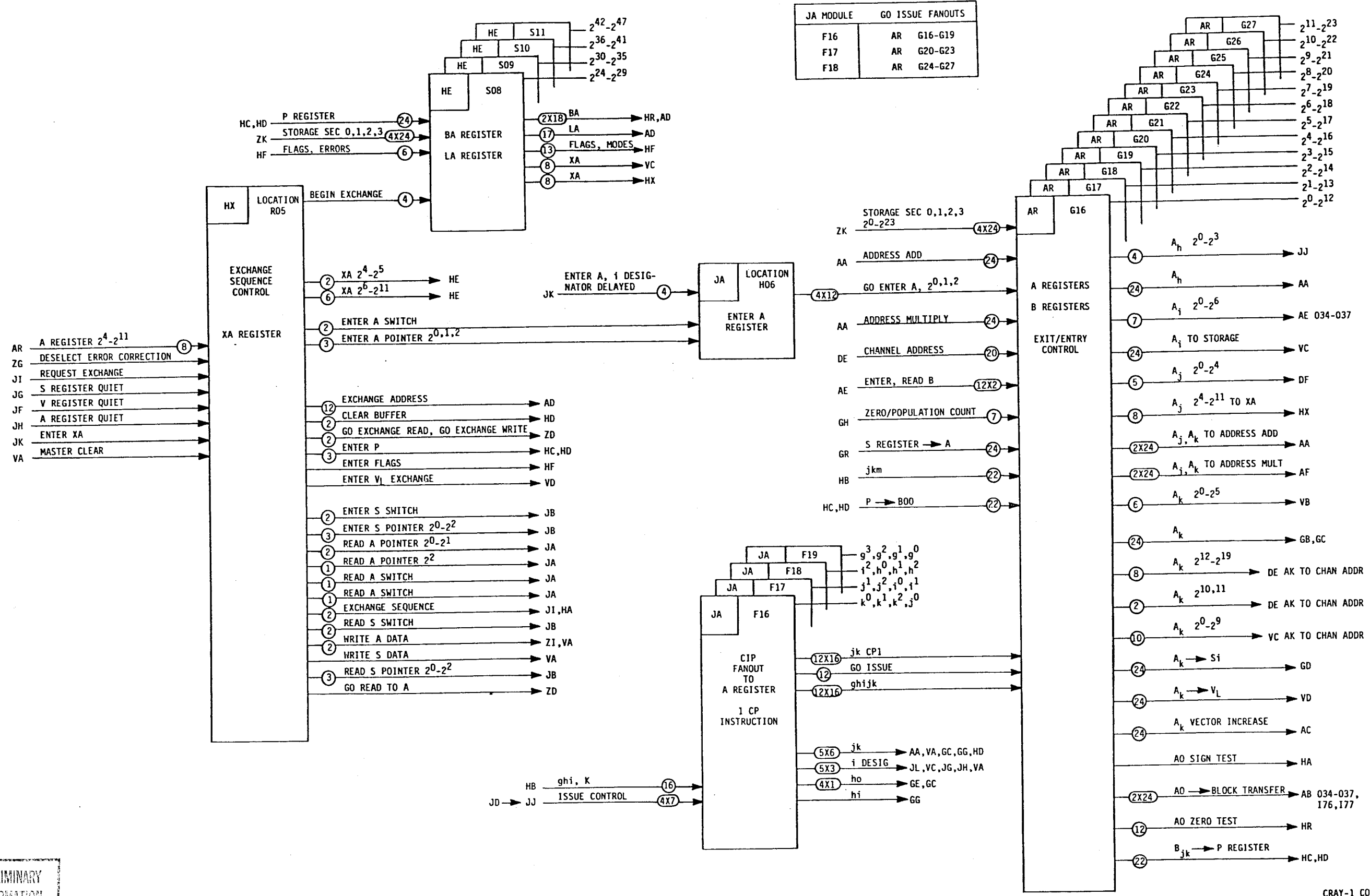

JB	GO ISSUE FANOUTS
F20	GR F28-F31
F21	GR G28-G31
F22	GR F32-F35
F23	GR G32-G35
F24	GR F36-F39
F25	GR G36-G39
F26	GR F40-F43
F27	GR G40-G43

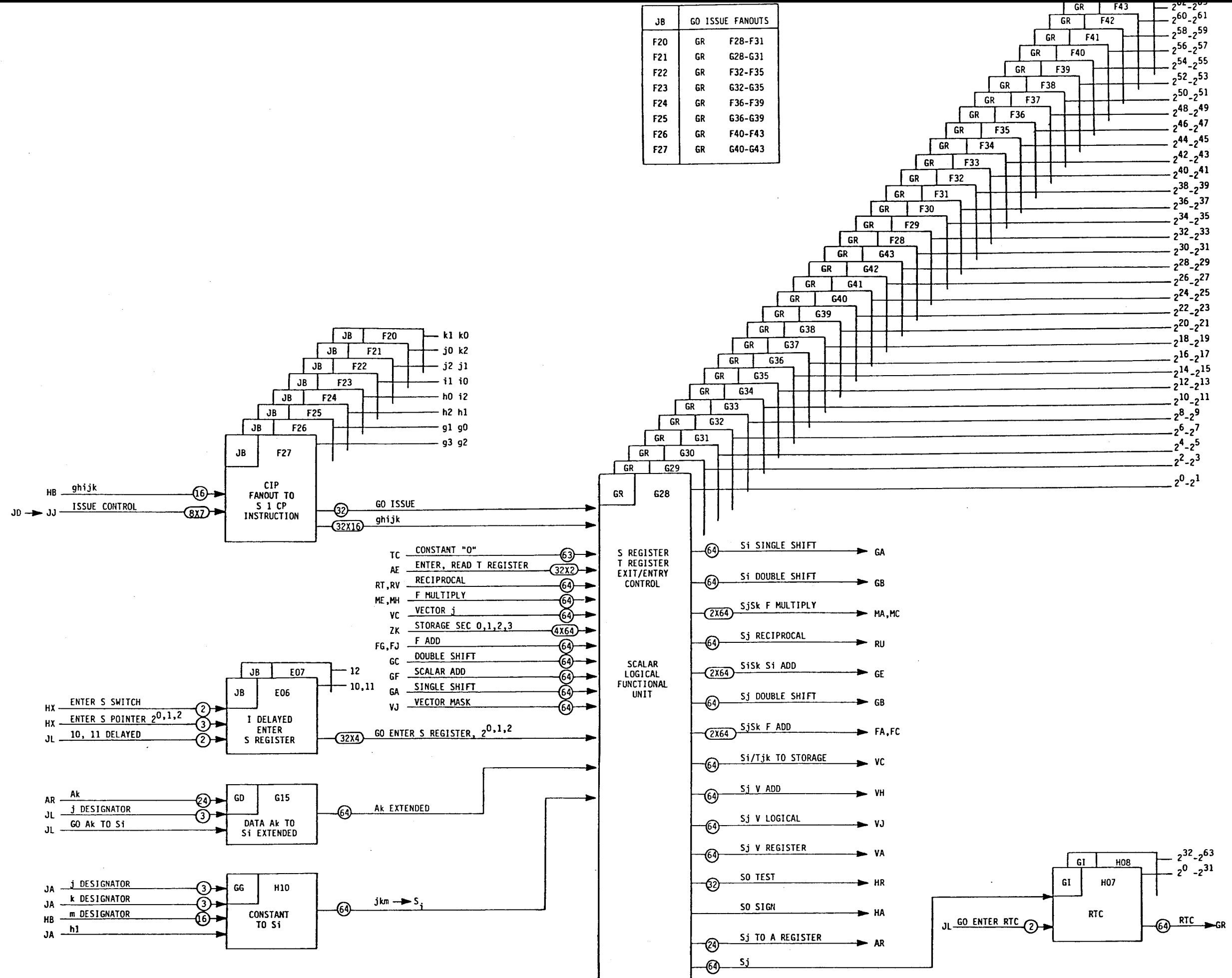

PRELIMINARY
INFORMATION

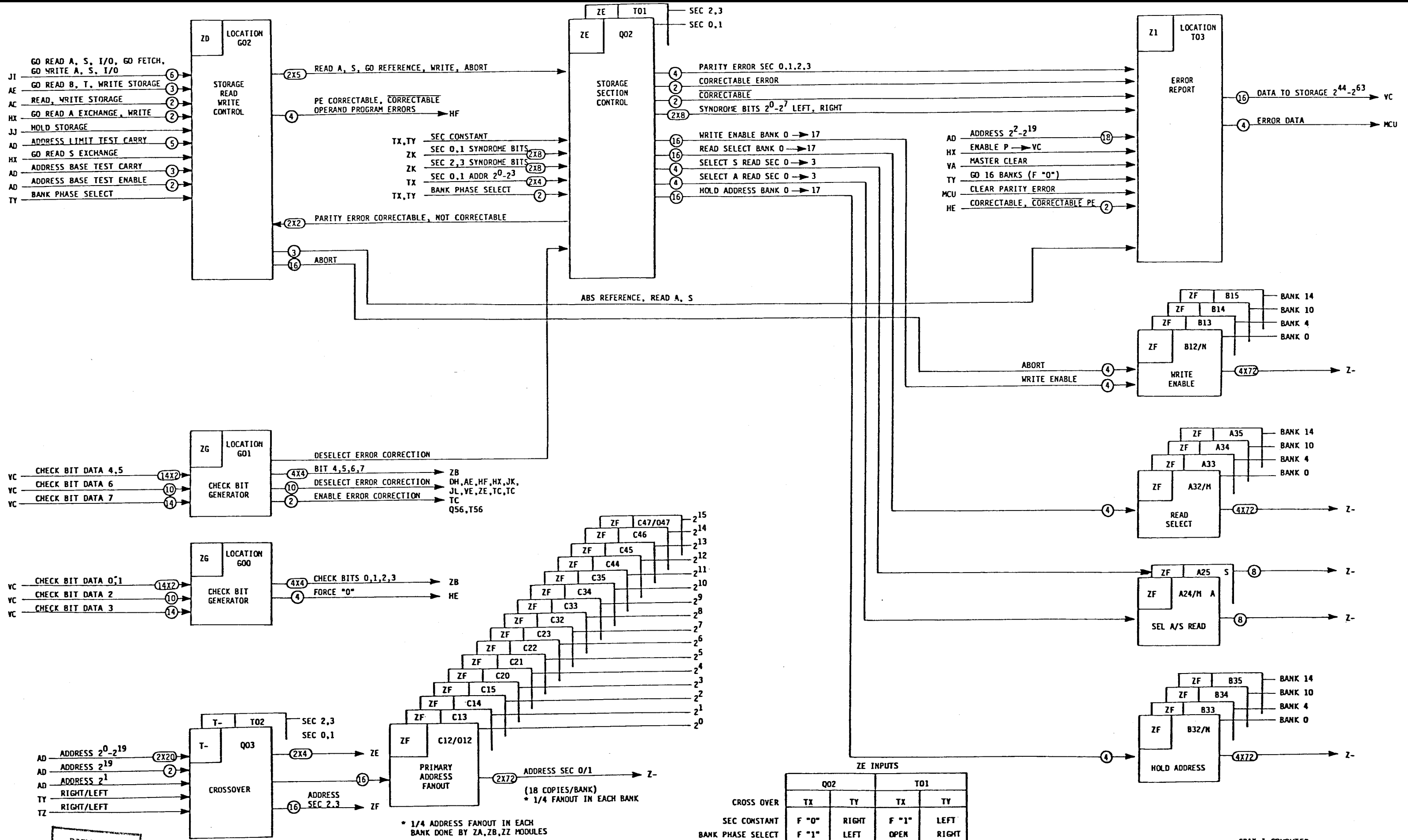

PRELIMINARY INFORMATION

CROSS OVER	Q02		T01	
	TX	TY	TX	TY
SEC CONSTANT	F "0"	RIGHT	F "1"	LEFT
BANK PHASE SELECT	F "1"	LEFT	OPEN	RIGHT

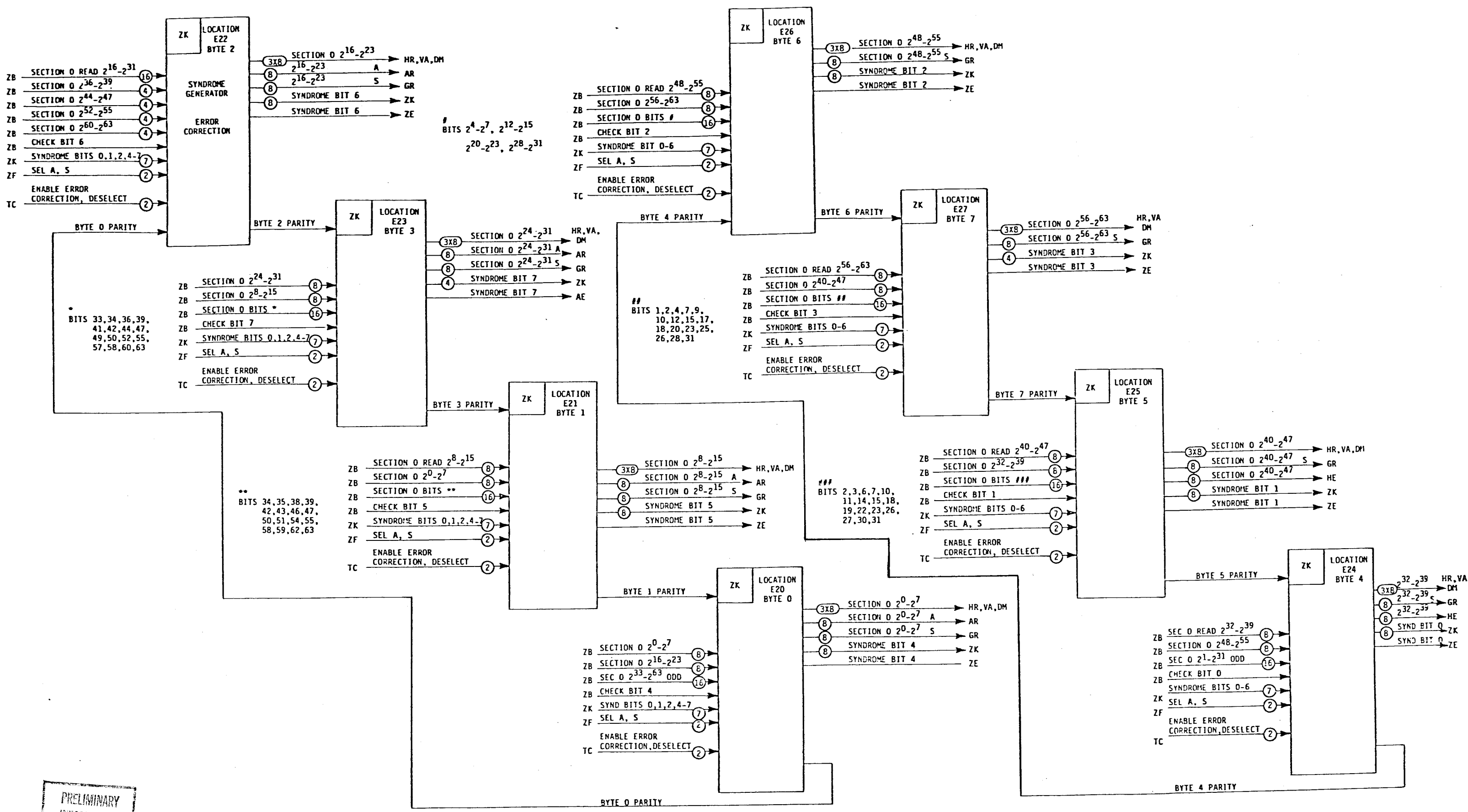

PRELIMINARY
INFORMATION

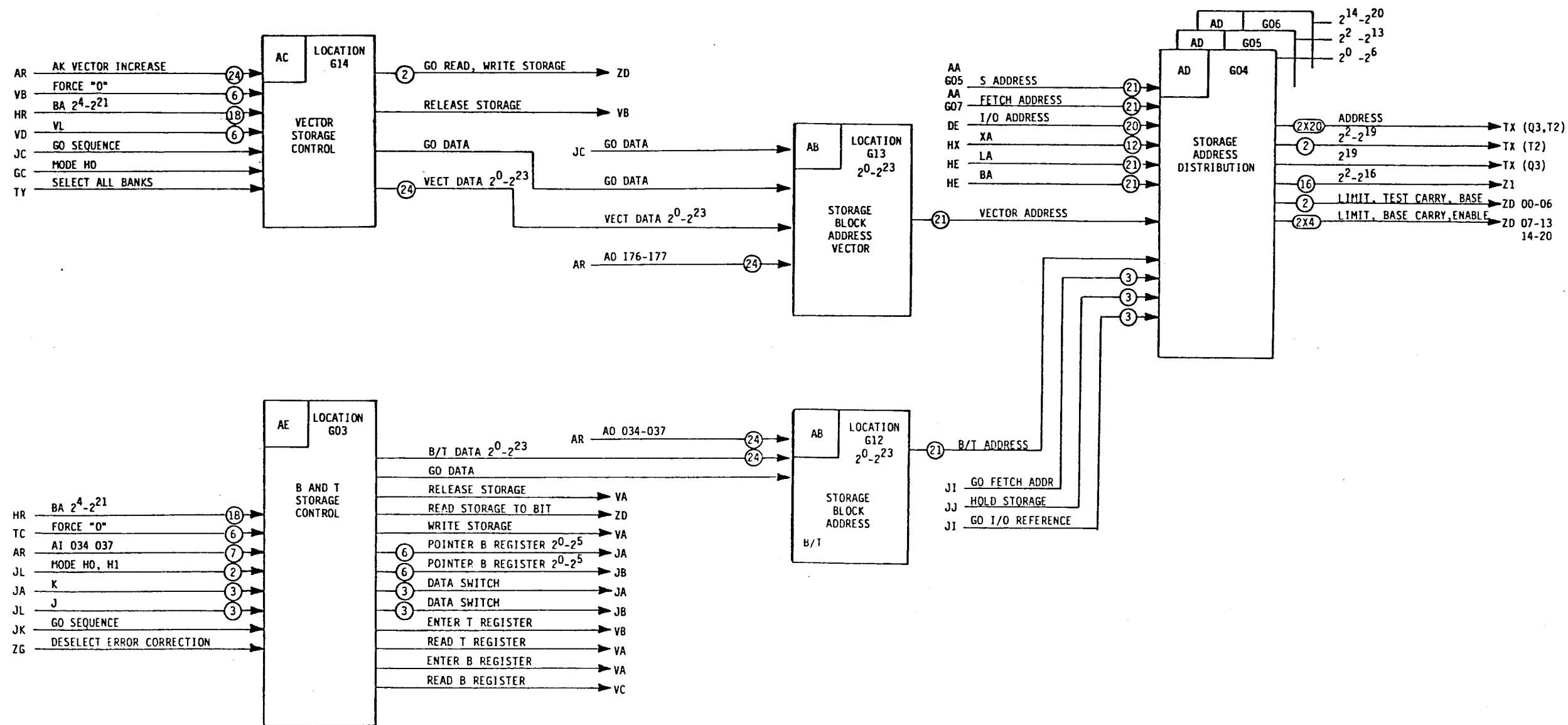

PRELIMINARY
INFORMATION

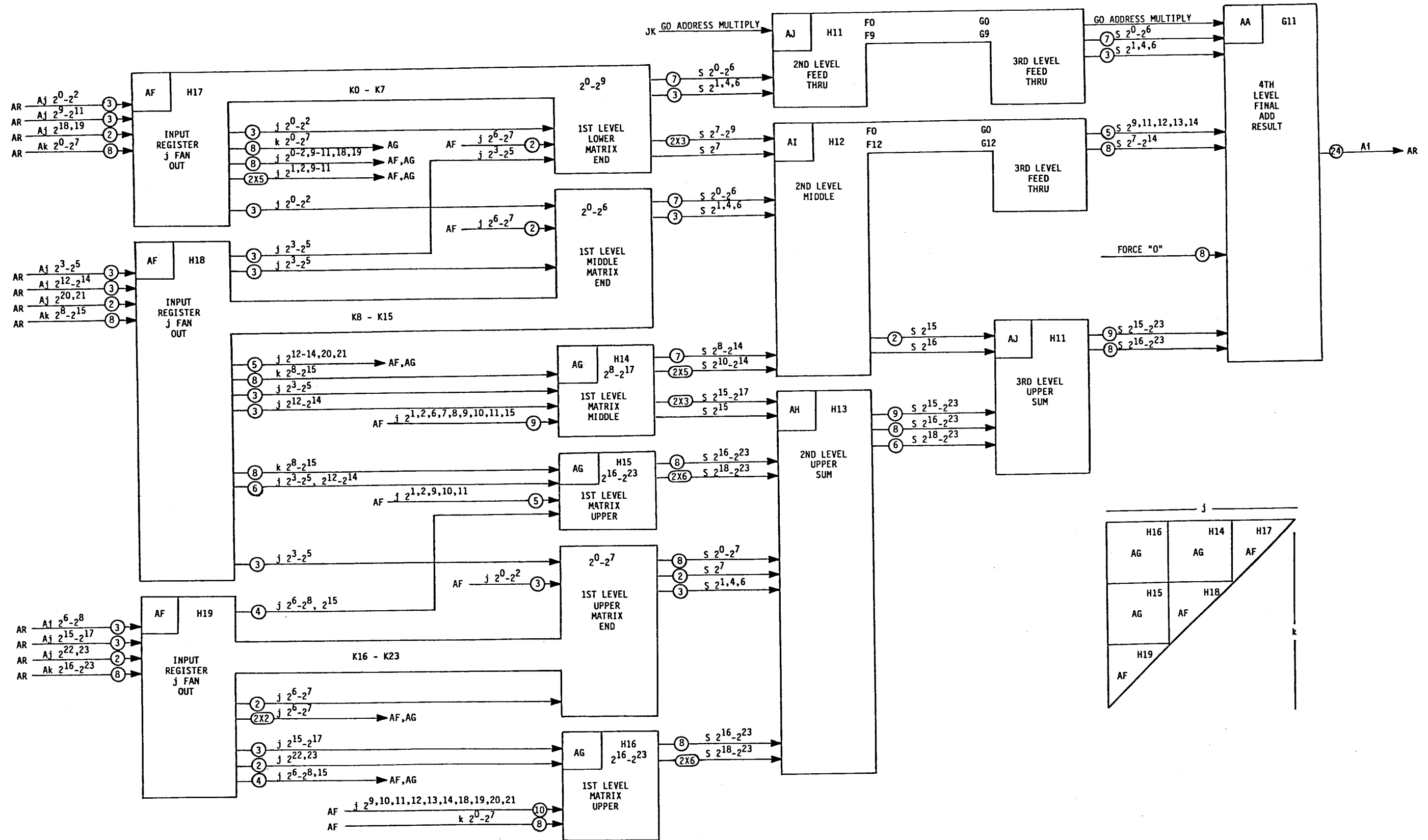

PRELIMINARY
INFORMATION

VECTOR LOGICAL

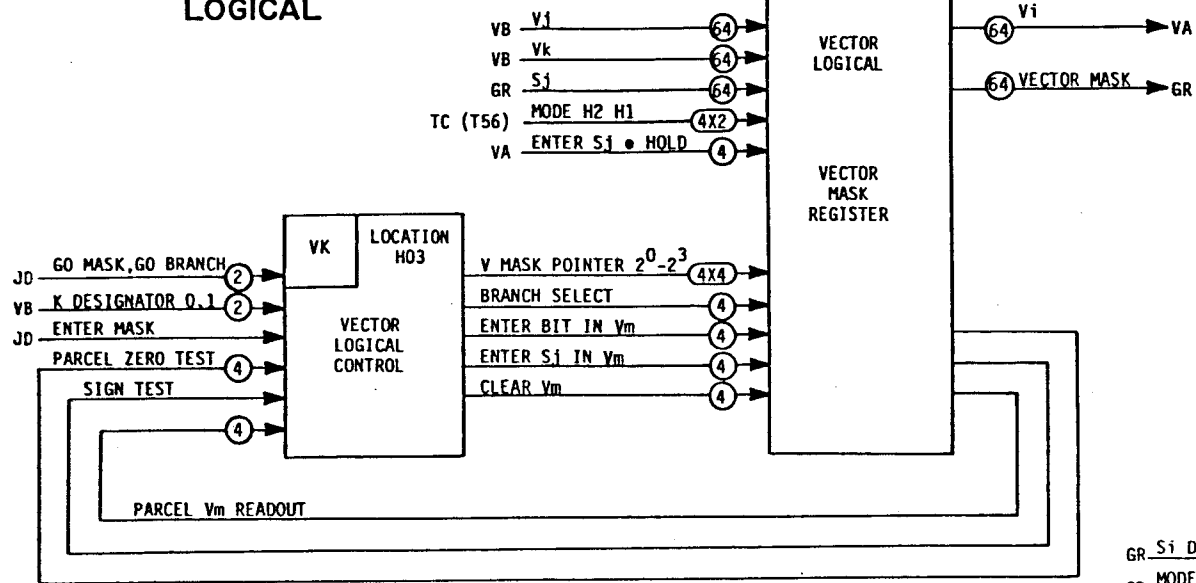

SCALAR SINGLE, DOUBLE SHIFT

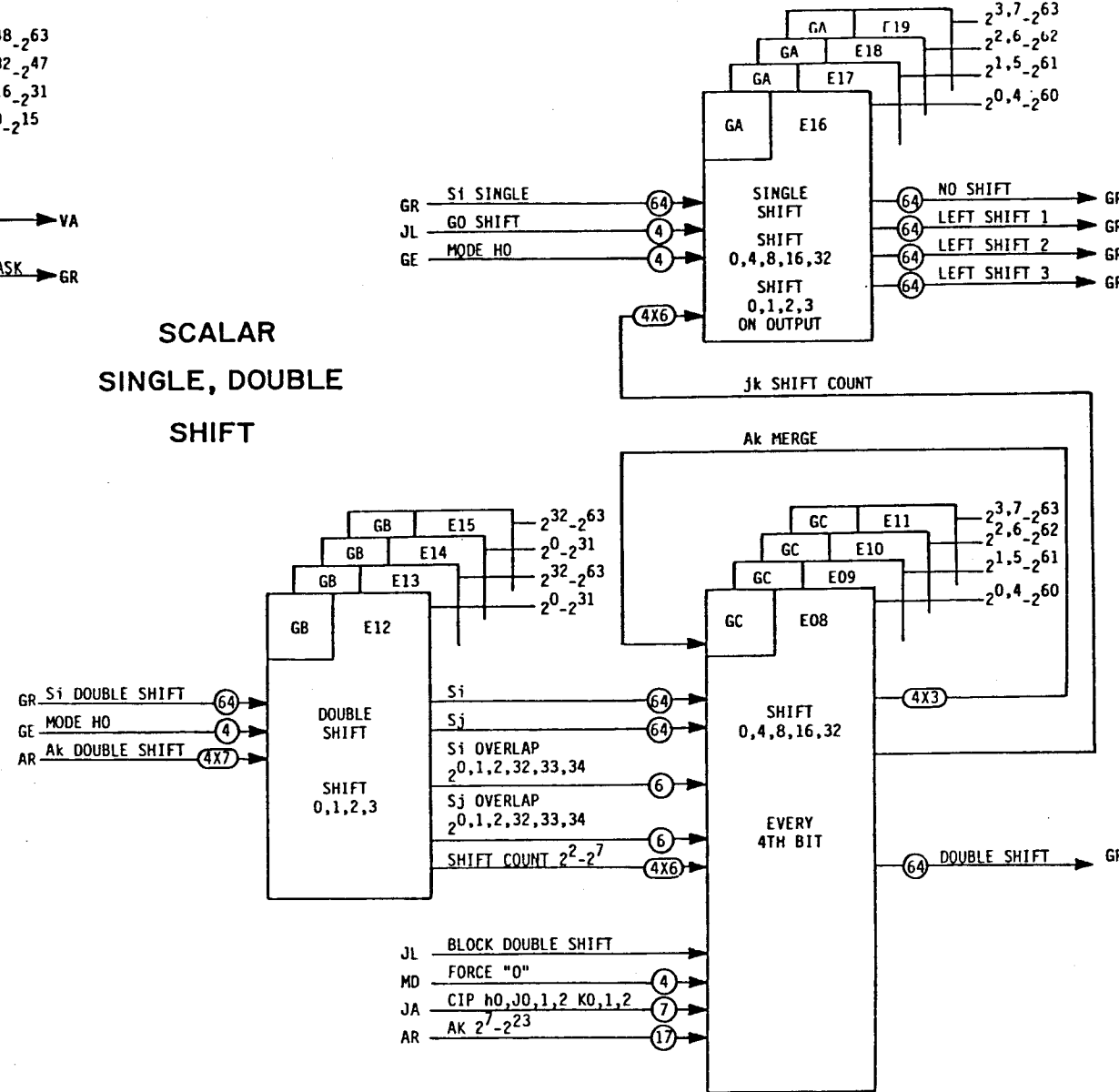

ADDRESS ADDERS

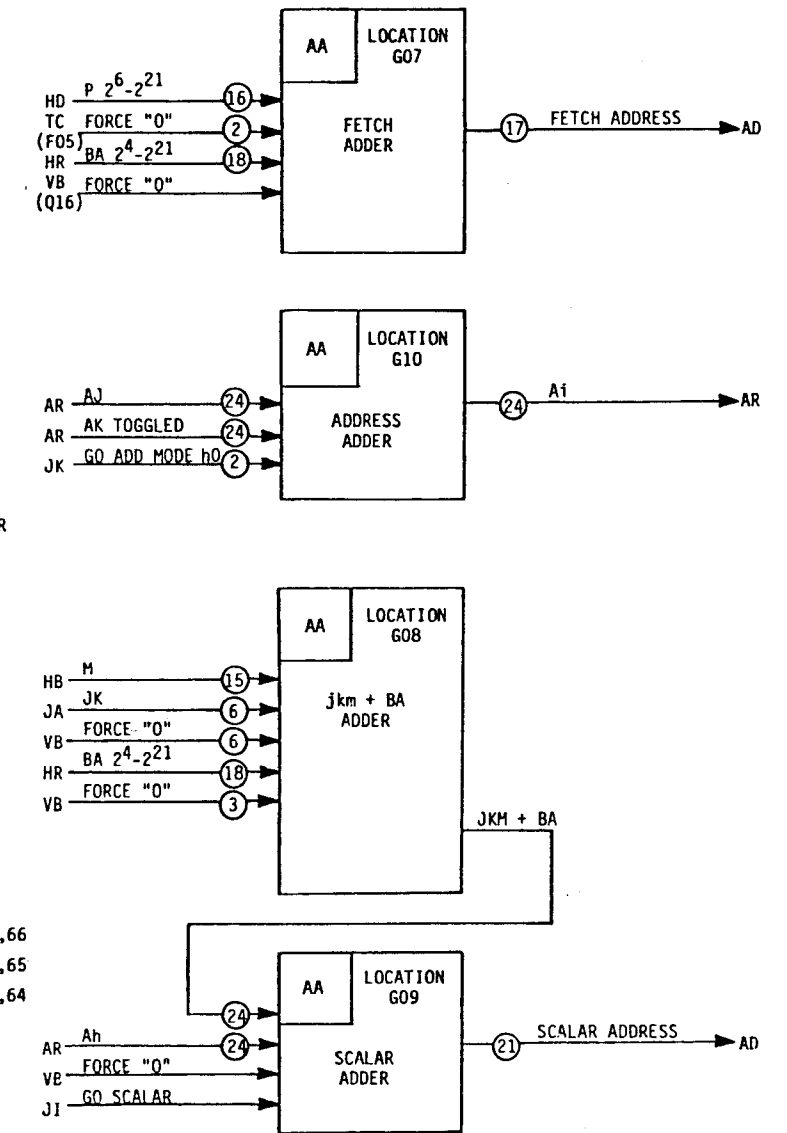

VECTOR ADD

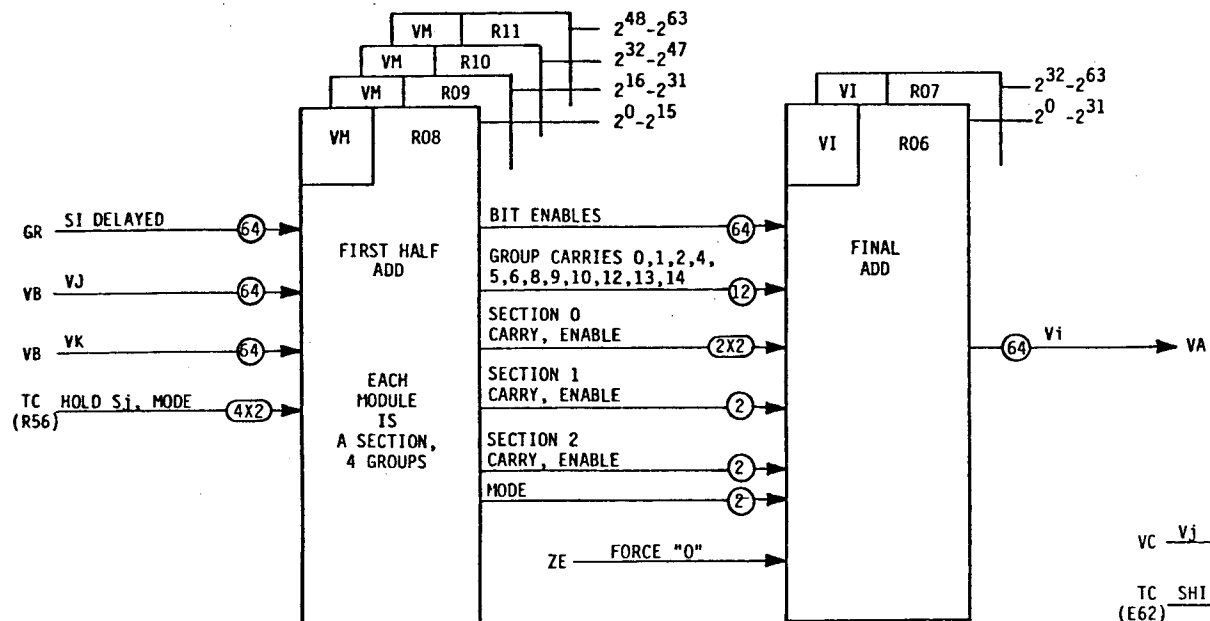

VECTOR SHIFT

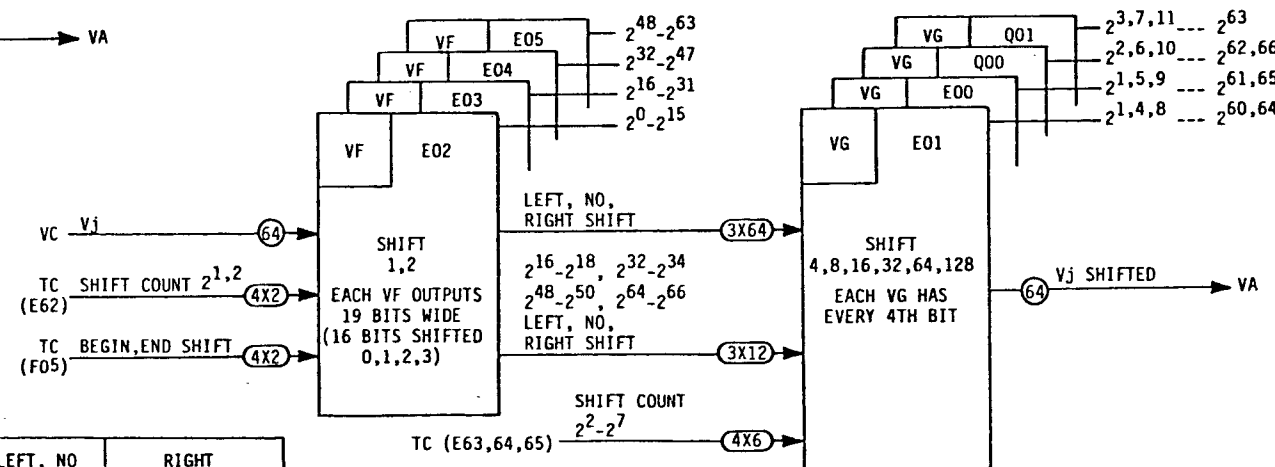

DUPLICATE BITS	LEFT, NO	RIGHT
E01	2 ^{16,32,48}	2 ^{16,32,48,64}
E00	2 ^{17,33,49}	2 ^{17,33,49,65}
Q00	2 ^{18,34,50}	2 ^{18,34,50,66}
Q01	-----	-----

PRELIMINARY INFORMATION

SCALAR ADD

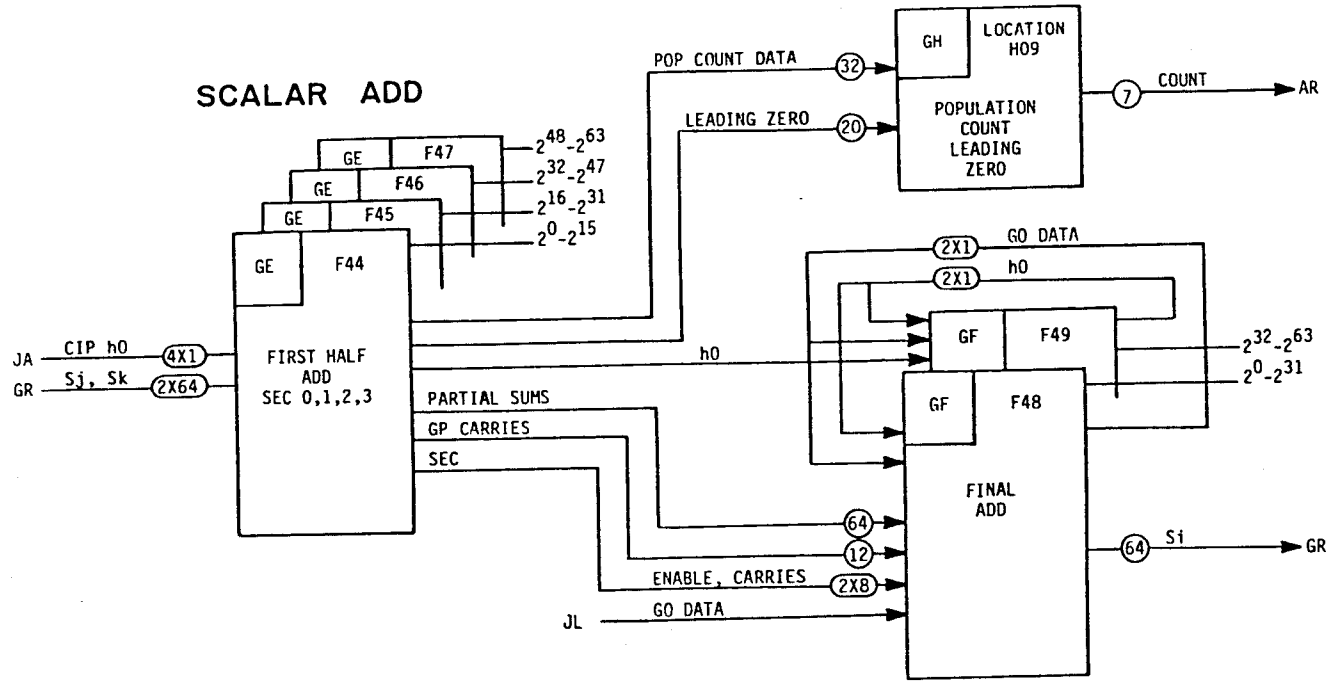

FLOATING ADD

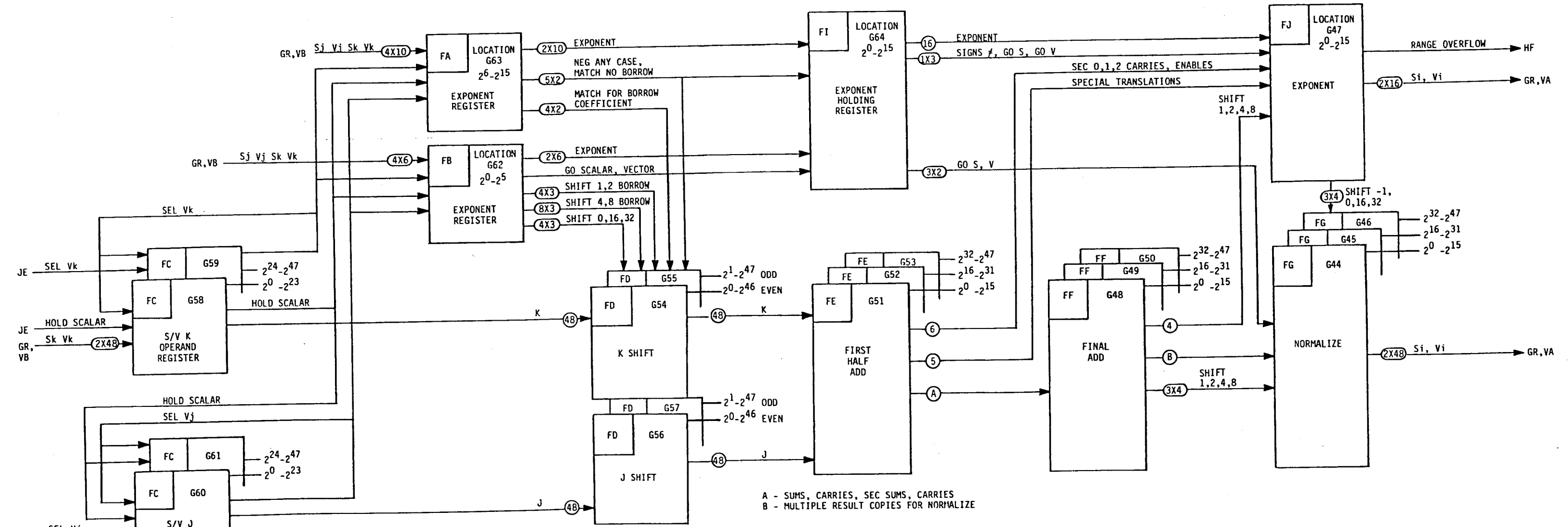

PRELIMINARY INFORMATION

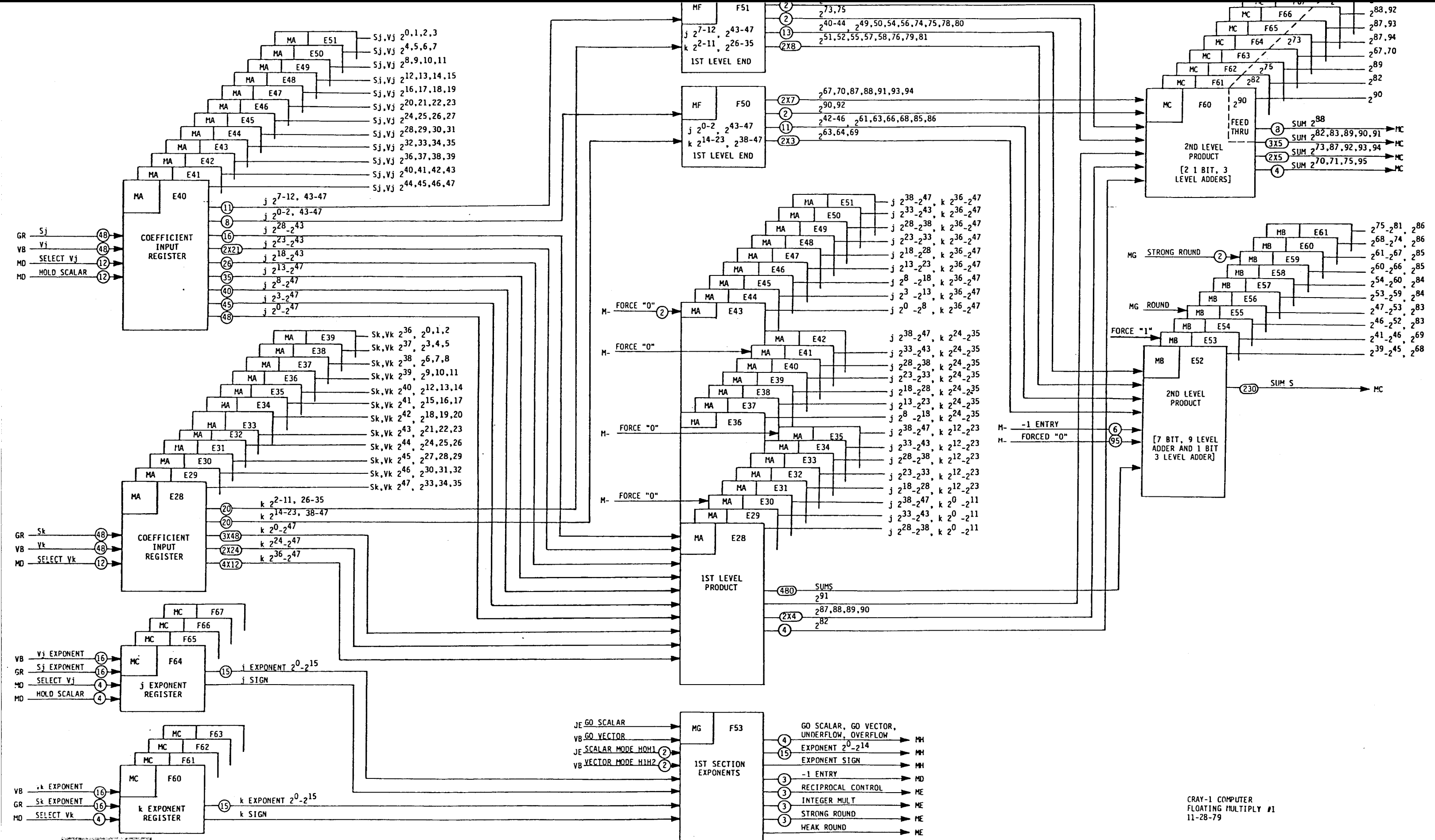

PRELIMINARY INFORMATION

ALL MODULES LABELED BY INPUT BITS

CRAY-1 COMPUTER
 FLOATING MULTIPLY #1
 11-28-79

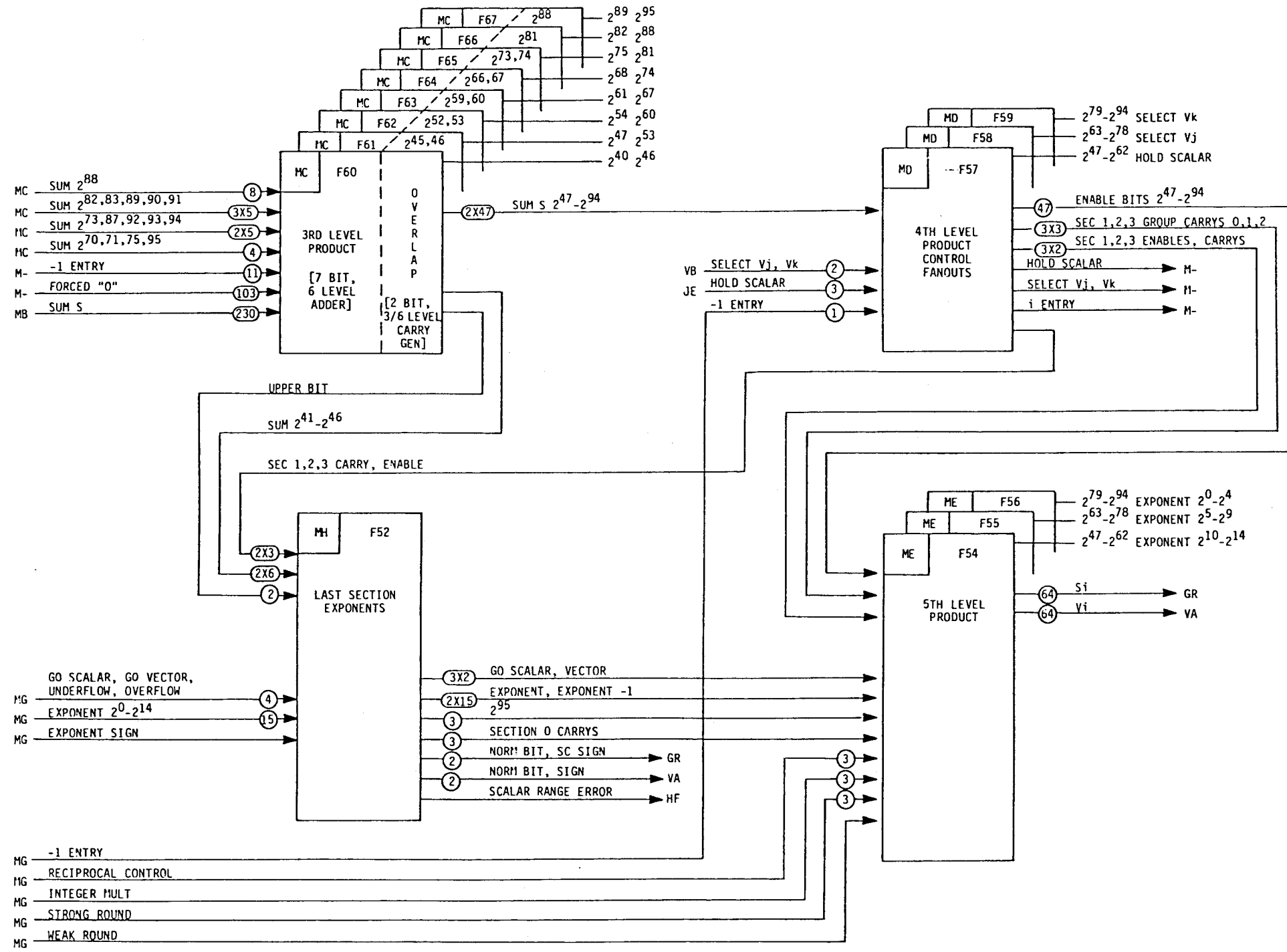

ALL MODULES LABELED BY INPUT BITS

PRELIMINARY
INFORMATION

The reciprocal unit has always been documented with some confusion as to what position and in the process errors were generated. I have tried to correct the errors and reduce the confusion.

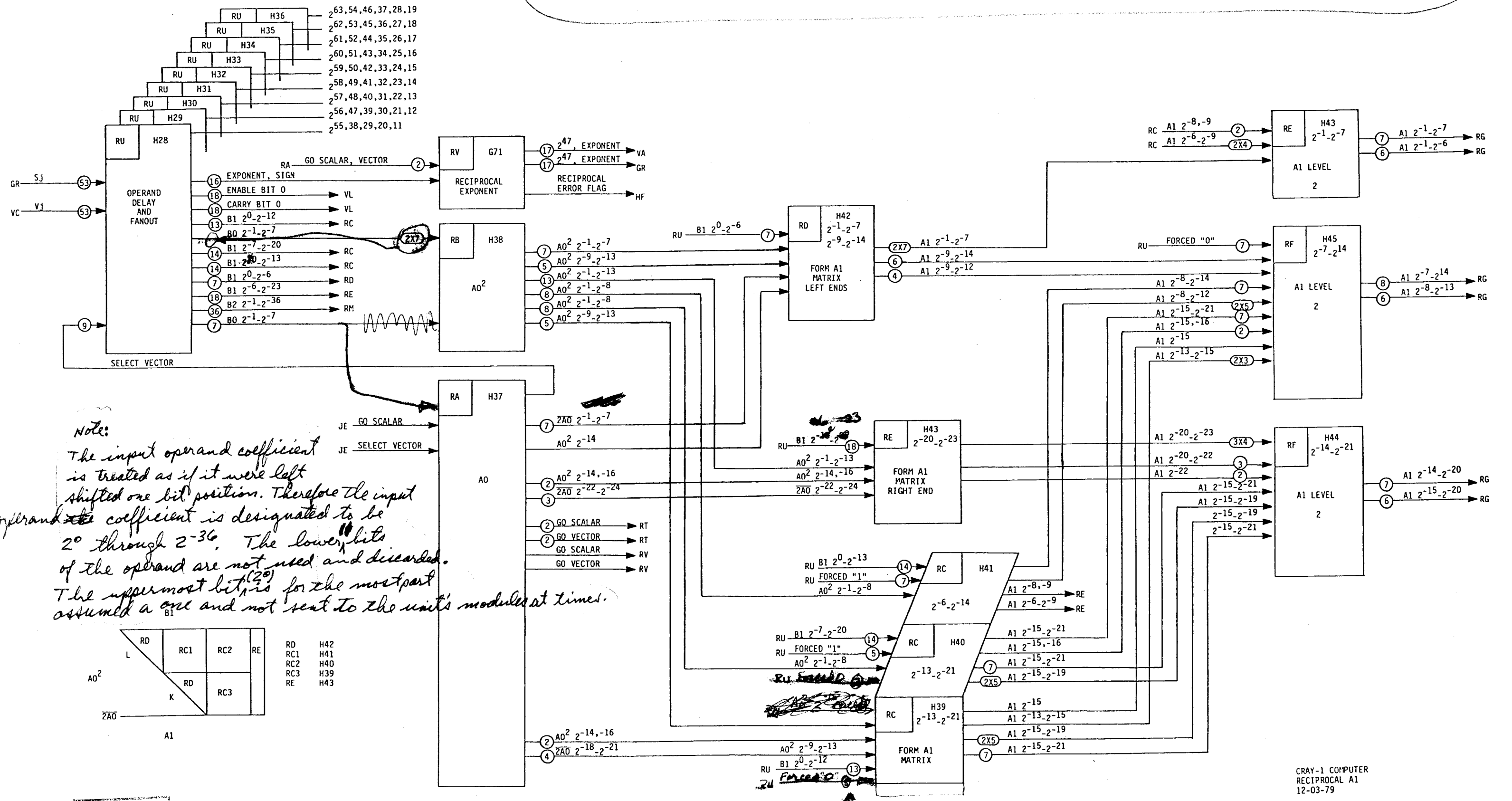

Note:
 The input operand coefficient is treated as if it were left shifted one bit position. Therefore the input operand coefficient is designated to be 2^0 through 2^{-36} . The lower bits of the operand are not used and discarded. The uppermost bit is for the most part assumed a one and not sent to the unit's modules at times.

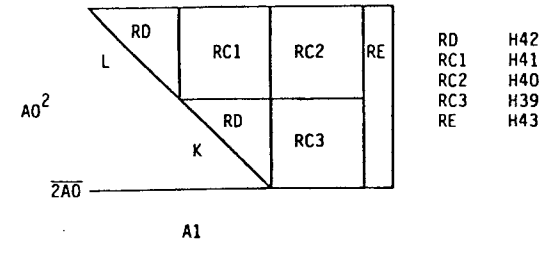

- RD H42
- RC1 H41
- RC2 H40
- RC3 H39
- RE H43

PRELIMINARY INFORMATION

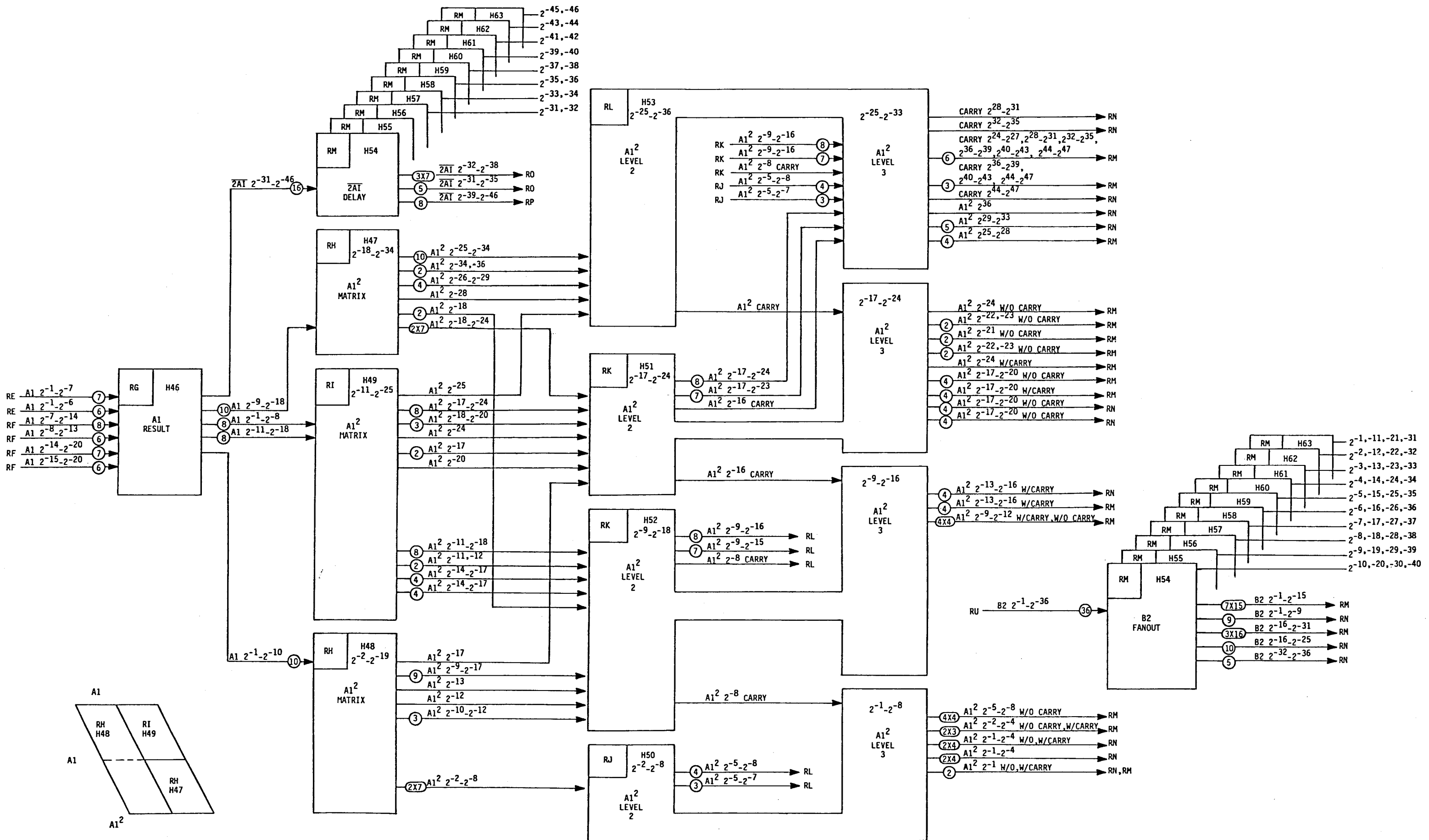

PRELIMINARY
INFORMATION

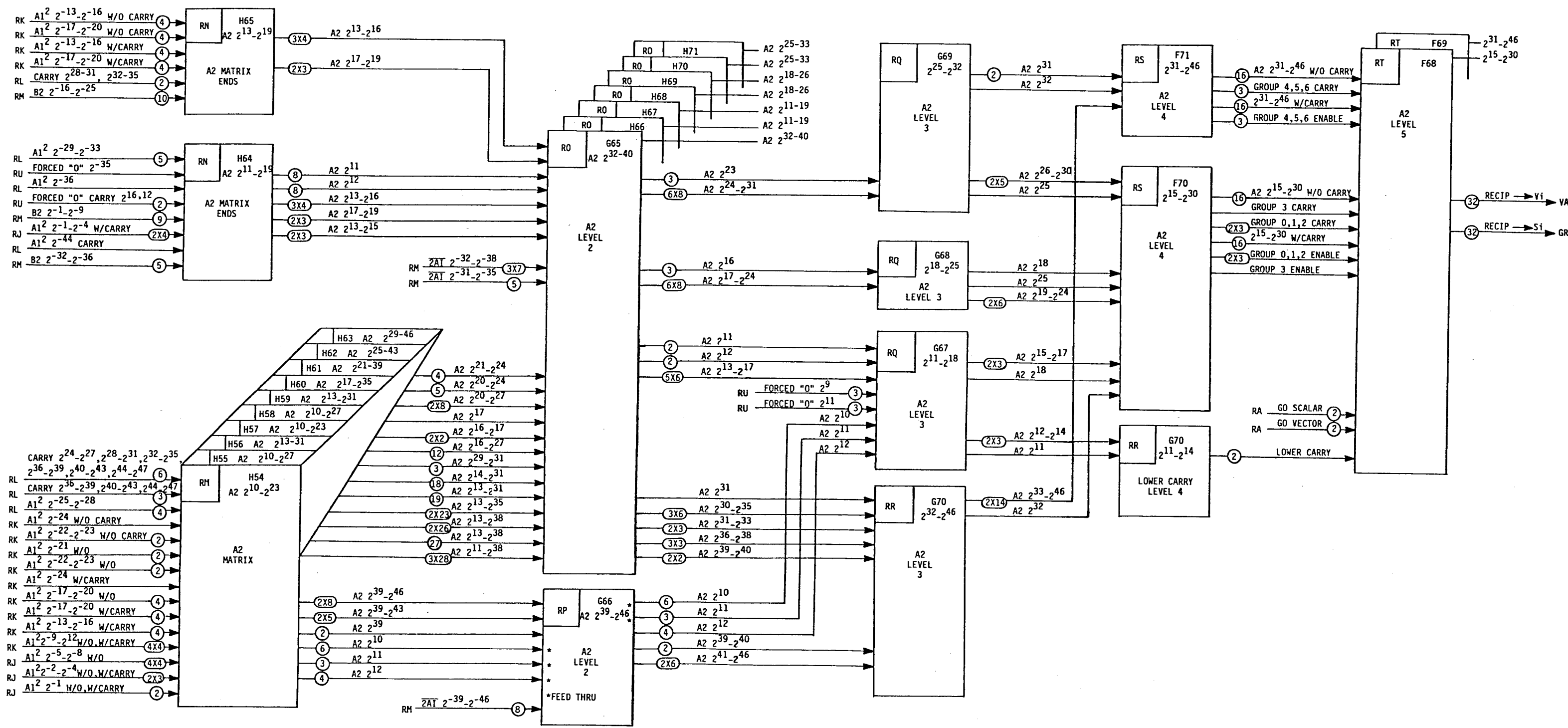

PRELIMINARY
INFORMATION