

**PRELIMINARY
SITE
PLANNING**



CRAY-1 COMPUTER

PRELIMINARY SITE PLANNING

CRAY-1 COMPUTER

The computer consists of the mainframe (CPU), power cabinet, two condensing units, and two motor-generators and control cabinets.

Computer room environment:

60° F to 80° F (16° C to 27° C)

35% to 65% R.H.

Voltages required:

480 volt 60 Hz

115 volt 60 Hz

False floor:

12-inch (30.5 cm) minimum height (subfloor to top of false floor)

Floor to be grounded to earth ground.

Site access requirements:

Doors:

Double doors with minimum clearance of 80-inch (203 cm) height and 60-inch (152 cm) width. If ramp and door are in close relationship required door height may be greater.

Ramp:

Maximum slope of 1 in 5.

General:

Access route to site must be strong enough to support rolling casters with 1500-pound loads. That applies especially to any ramps where the unit is most vulnerable. Customer should have 1/4-inch thick Masonite (not plywood) available for covering false floor and tiled areas during the moving-in process.

CRAY-1 CPU

Description:

Refrigerant-cooled unit that contains the modules and D.C. power supplies. Unit breaks down into one piece approximately 54 inches (137 cm) in diameter by 75 inches (191 cm) high, plus six power supply sections of slightly triangular shape of roughly 38 inches (97 cm) by 24 inches (61 cm) by 18 inches (46 cm) high. Entire assembled unit weighs about 10,000 pounds (4536 kg), with the center part of the unit weighing 6000 pounds (2722 kg). Floor loading for the center section is 7 pounds to the square inch (.5 kg/cm²).

Wiring (see Power Wiring schematic):

Unit requires thirty-six 3-wire circuits to the power cabinet plus two optional 115-volt circuits for convenience outlets. All additional cables are furnished by Cray Research, Inc.

Cooling (see Underfloor Refrigeration drawing):

Refrigerant piping must be installed, tested, and ready for hookup prior to the computer delivery. CRI will attach hoses between the prepared lines and the computer during the installation.

Floor preparation (see Floor Cutout drawing):

Unit requires accurate placement and sizing of floor cutouts. All floor stringers so noted must be removed and additional floor supports added where specified.

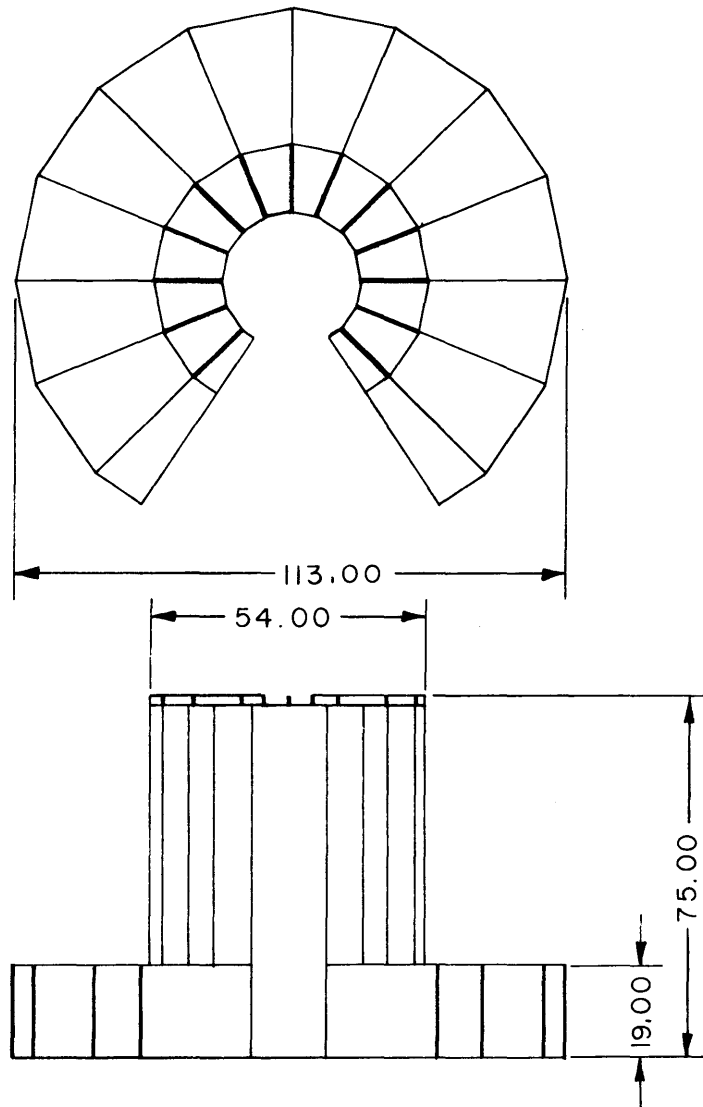

CRAY I COMPUTER CPU

POWER REQ'D: TWO, 15 AMP, 115 V, 60 Hz CIRCUITS
(MAIN COMPUTER POWER FROM POWER CABINET)

APPROX. WT. : 10,000 lbs

CRAY-1 POWER CABINET

Description:

Fan-cooled (room air) unit that contains the power supplies variable transformers, system ON-OFF control, warning circuits, temperature monitoring, plus other related functions.

Wiring (see Power Wiring schematic):

Customer to install 400-Hz and 60-Hz circuits, motor-generator and condensing unit control wires, plus the 36 circuits to the CPU power supplies. CRI will install miscellaneous signal cables.

Floor preparation (see Floor Cutout drawing):

Cut out floor tile and remove stringer as shown. Additional floor support may be required to keep cut floor tile in place.

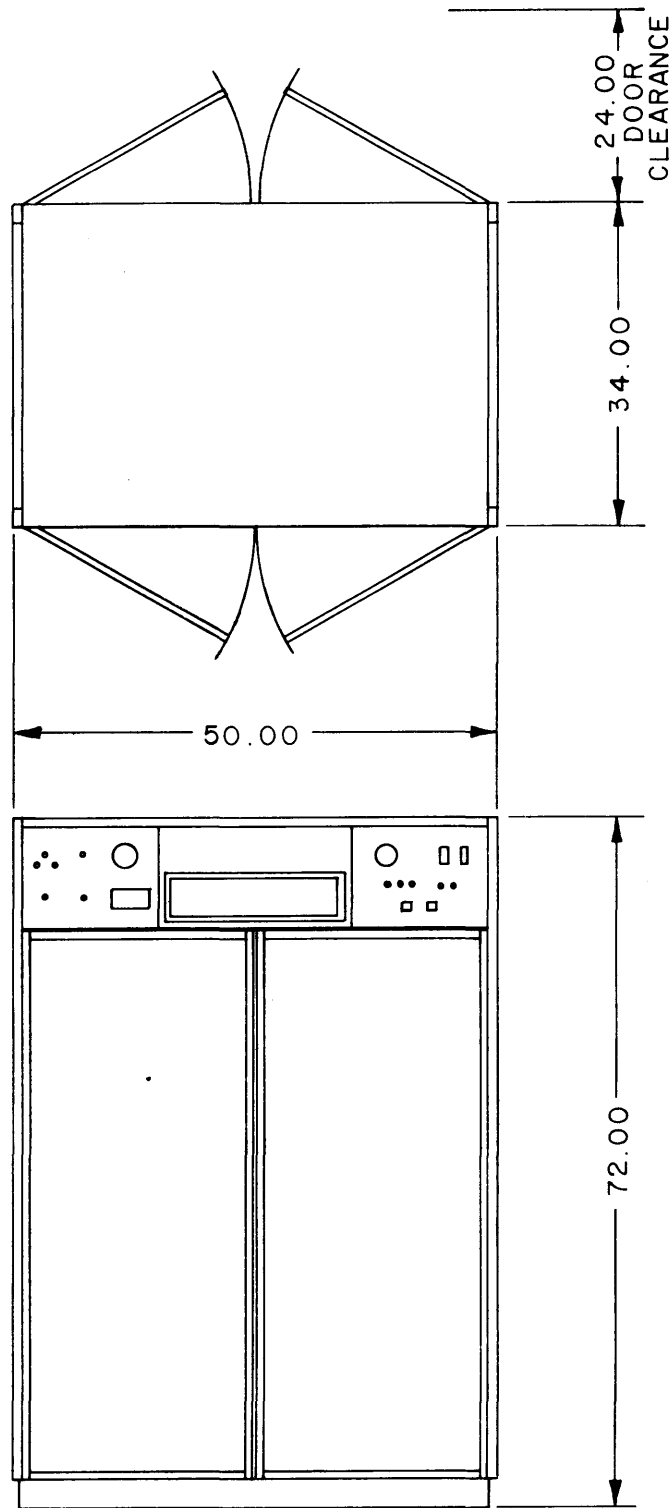

**CRAY I COMPUTER
POWER DISTRIBUTION CABINET**

POWER REQ'D: SIX, 60 AMP, 208 V, 3 ϕ , 400 Hz CIRCUITS

ONE, 15 AMP, 115 V, 60 Hz CIRCUIT

APPROX. WT. : 1500 lbs

APPROX. ROOM HEAT LOAD: 4000 BTU/HR

REVISIONS					
REV.	ECO.	DESCRIPTION	DRFT.	DATE	APP'D

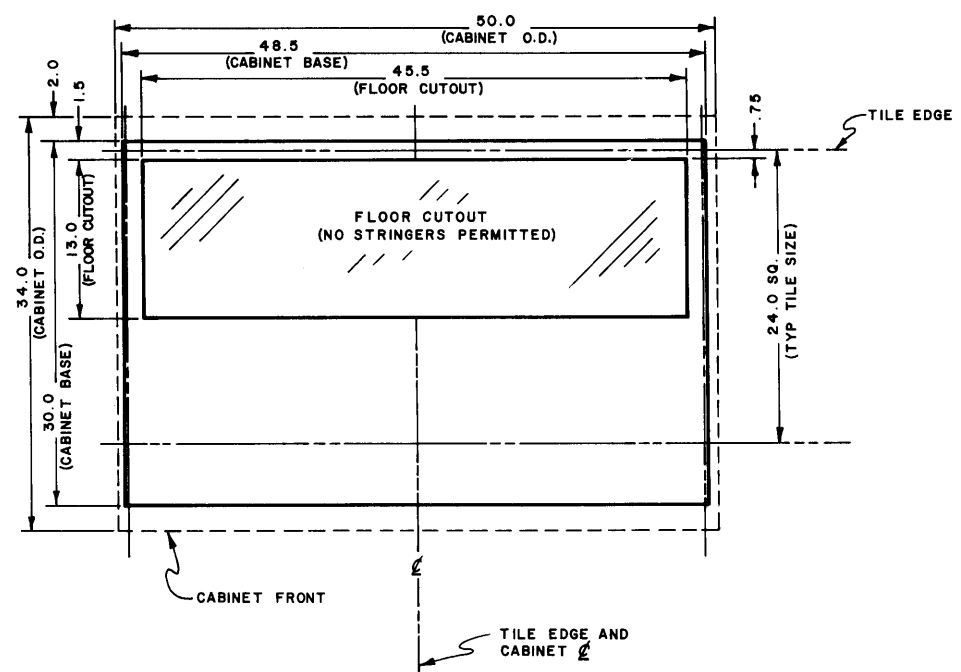

PART NUMBER	REV.

NOTE:

- FRONT 3 INCHES OF CUTOUT USED FOR ENTRANCE OF 6 - 60 AMP 3 PHASE, 400 Hz CIRCUITS (1 1/2" KO'S)
- REAR 8 INCHES OF CUTOUT USED FOR POWER CABLES TO MAIN FRAME (36 - 3/4" KO'S) PLUS 8 - 1/2" KO'S FOR MISC. CABLES.

ITEM	REQ'D	PART NUMBER	DESCRIPTION	MATERIAL
LIST OF MATERIAL				

MATERIAL	CRAY RESEARCH INCORPORATED			TITLE		
				POWER CABINET		
FINISH	PROJECT BY <i>JK</i> DATE <i>6/8/78</i>			INSTALLATION INFORMATION		
				CRAY-1 COMPUTER		
REMOVE ALL BURRS	DRWN	CHK'D	APP.	FRAC.	SIZE	PART NUMBER
BREAK SHARP EDGES & CORNERS				DEC.		
DO NOT SCALE				ANG.		
				SCALE	WEIGHT	SHEET
				1/8		OF

CRAY-1 CONDENSING UNIT
(two required)

Description:

Twenty-horsepower water-cooled condenser with controls for high, low, and oil pressures. Cabinet can be furnished with skins, but if units are installed in equipment room side skins will not be furnished.

Wiring (see Power Wiring schematic and Condensing Unit Installation drawing):

Customer installed.

Piping (see Condensing Unit Installation drawing):

Water:

1-1/4-inch pipe, locations per drawing.

Refrigerant:

Sizes per drawing. Customer to provide access fittings for line evacuation after unit is attached. Specific drawings for individual site will be furnished by CRI.

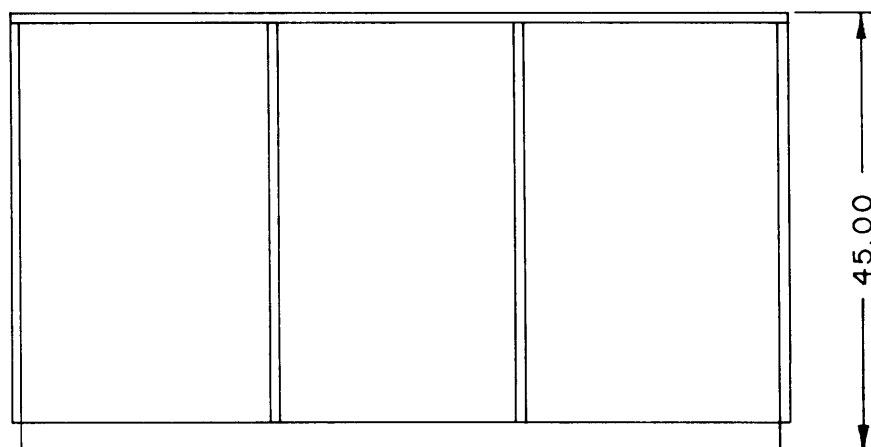
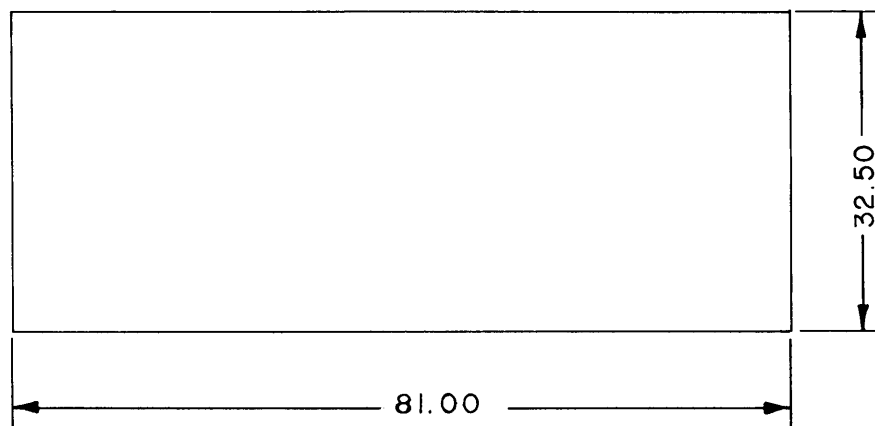

CRAY I COMPUTER CONDENSING UNIT

POWER REQ'D: 50 AMP, 460 V, 3 ϕ , 60 Hz CIRCUIT

WATER REQ'D: 45° TO 75° F (20 GPM, 3 PSI DROP at 75° F)

APPROX. WT.: 1400 lbs

ESTIMATED ROOM HEAT LOAD: 18000 BTU/HR

CRAY-1 MOTOR-GENERATOR

(two required)

Description:

150 KVA, 208 volt, 3 phase, 400 Hz output motor-generator.
200 HP, 480 volt, 3 phase, 60 Hz drive motor and a 10 HP
pony start motor. Each motor-generator with a control
cabinet.

Wiring:

Units are wired both for running with the outputs hooked
together through the control cabinets for alternate operation
and for standby usage.

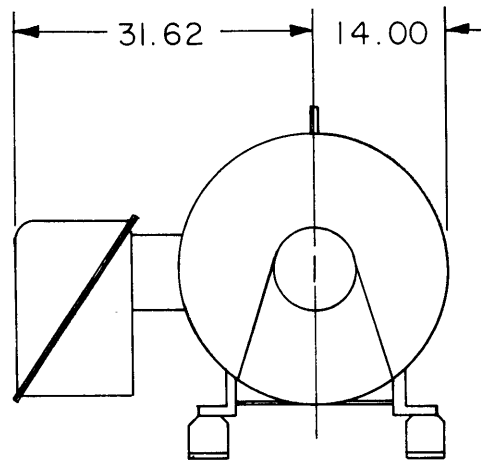
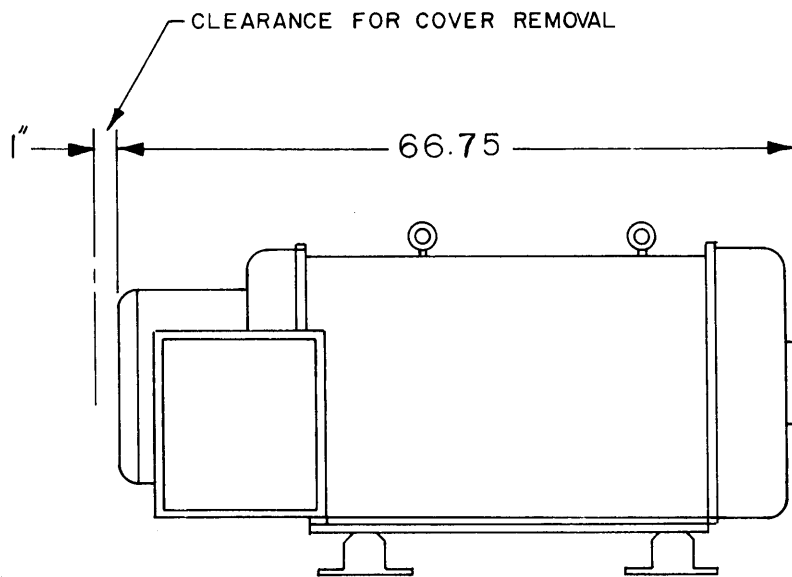

150 KVA MOTOR GENERATOR

250 AMP, 460 V, 3 ϕ , 60 Hz

200 HP MOTOR, 10 HP PONY-MOTOR

APPROX. WT.: 3900 lbs

APPROX. ROOM HEAT LOAD: 90,000 BTU/HR

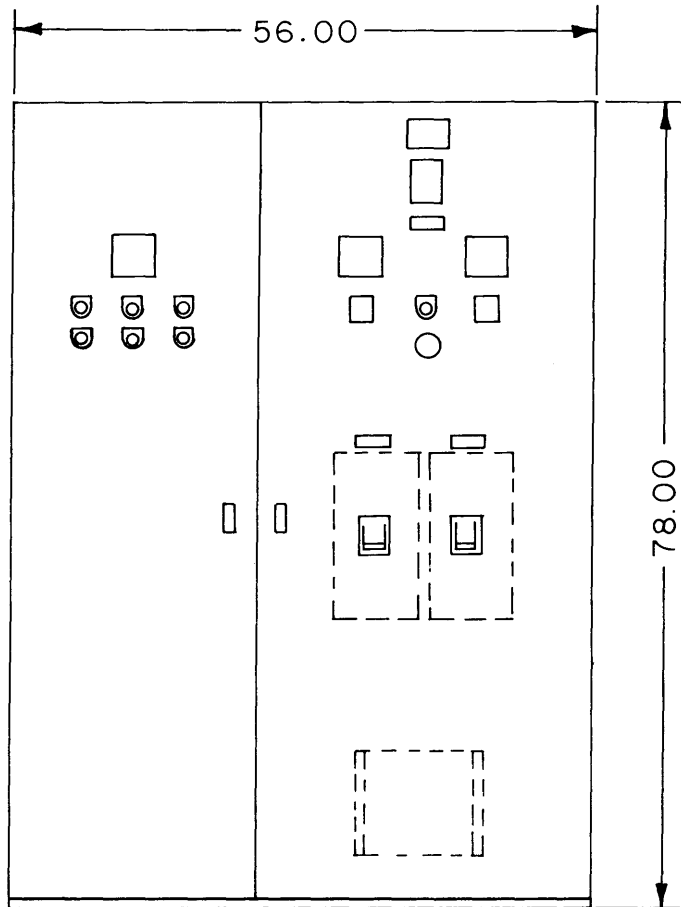
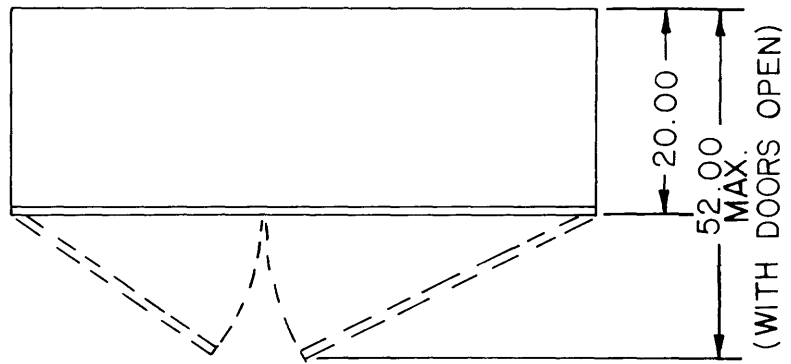

**CONTROL CABINET,
MOTOR GENERATOR**

APPROX. WT. : 1100 lbs

CRAY-1 MCU I/O SYSTEM

This system consists of a CPU, tape drive, and controls in a rack-mounted package plus a disk pack drive, line printer, card reader, and two terminal displays. A four-foot desk and a stand are provided for the terminals.

CPU-tape drive unit:

Fan cooled using room air. Attached drop cord for 208-volt power and external male receptacle for standard 115-volt extension cord.

Disk-pack drive:

Power from control in above unit. Power and logic cables furnished.

Line printer:

Standard 115-volt extension cord--furnished by CRI.

Card reader:

Standard 115-volt extension cord--furnished by CRI.

Terminal displays:

Standard 115-volt extension cord--furnished by CRI.

Customer is to provide the means to plug in all of the above equipment.

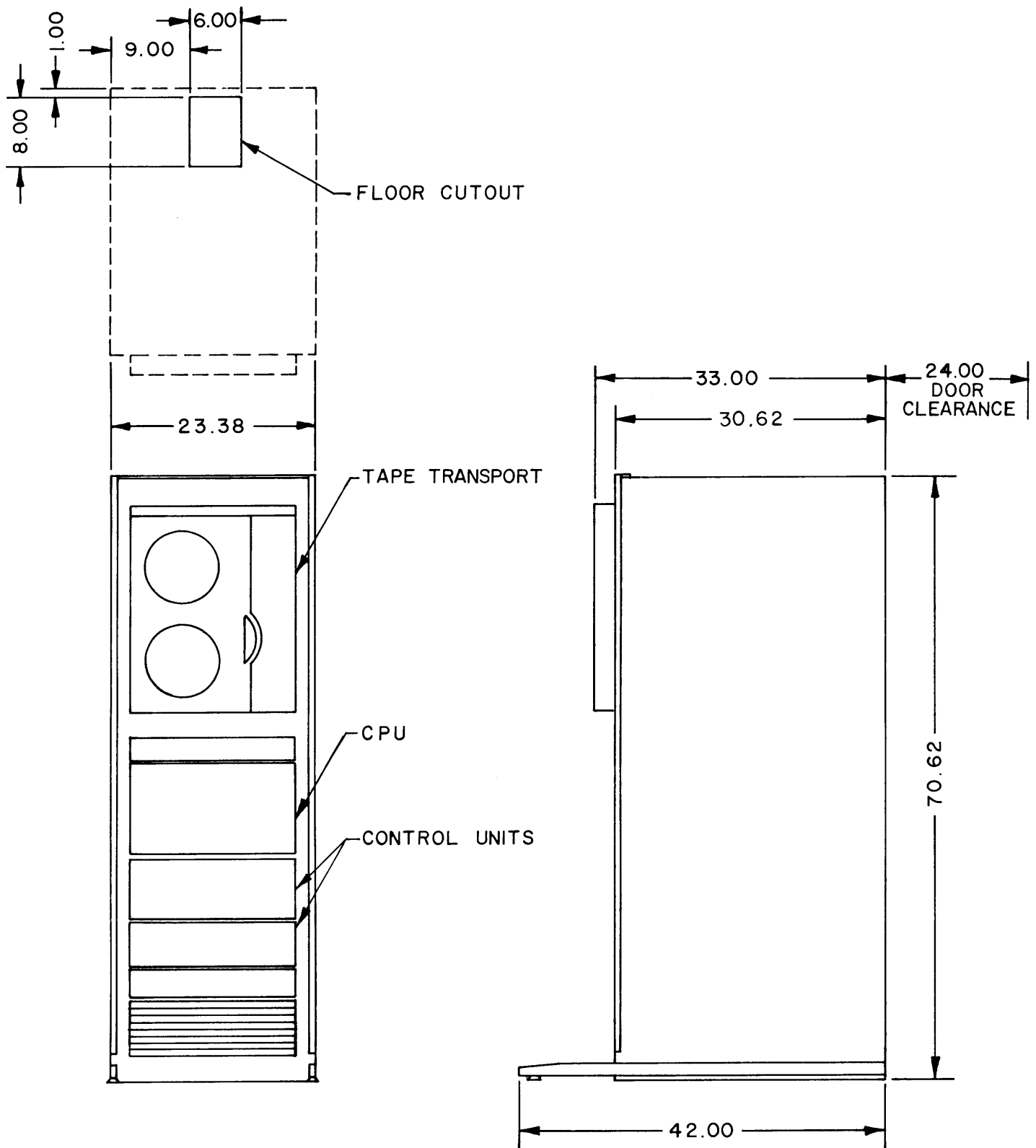

**CPU, TAPE & CONTROL UNIT
CRAY I MCU**

POWER REQ'D: 208 VAC, 3 Ø, 60 Hz, 20 AMP CIRCUIT
115 VAC, 60 Hz, 15 AMP CIRCUIT

WEIGHT: APPROX: 500 lbs

ROOM HEAT LOAD: APPROX. 6000 BTU/HR

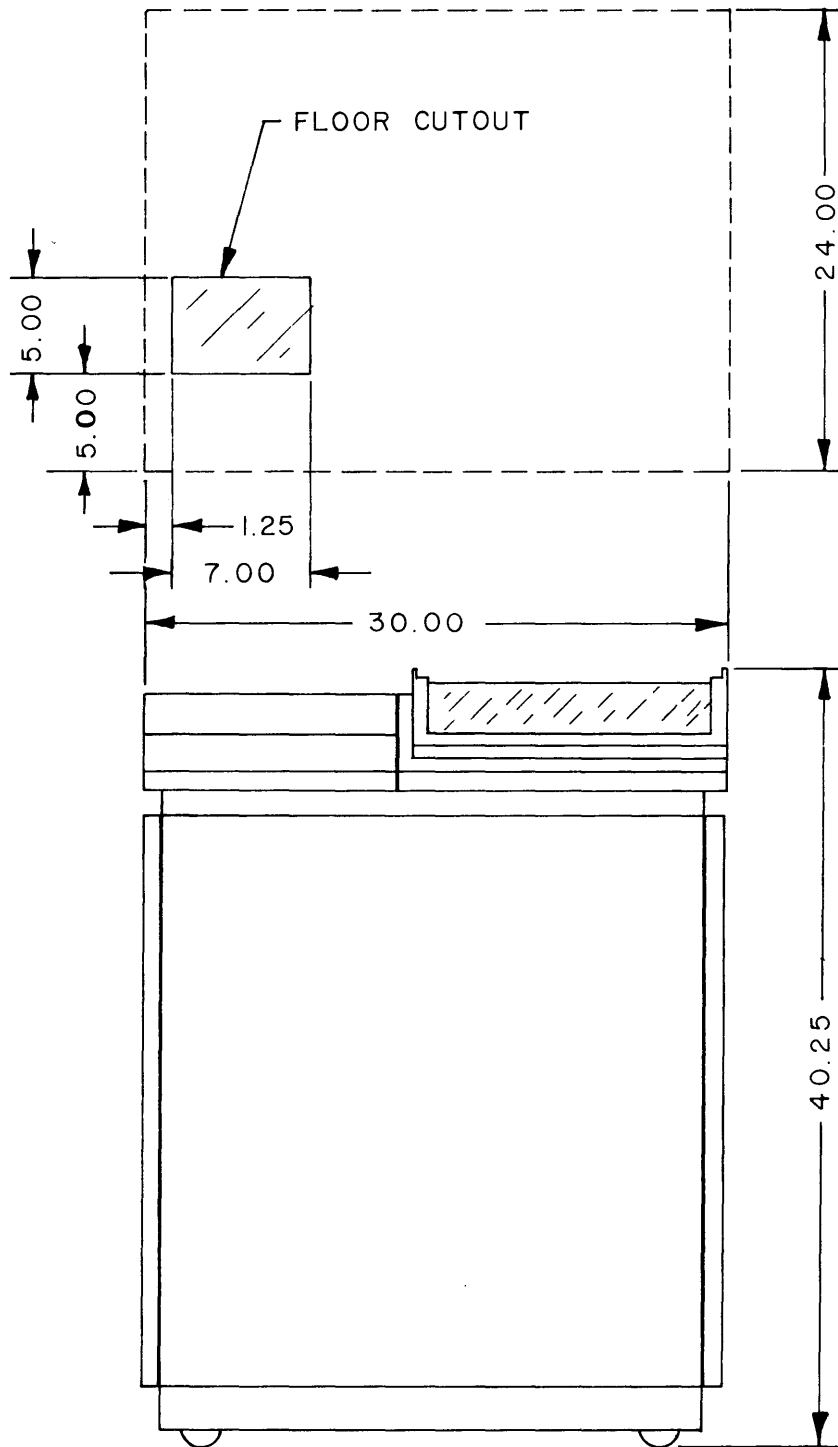

**DISC - PACK DRIVE
CRAY I MCU**

POWER REQ'D: FROM CONTROL UNIT - 208 OR 230 VAC,
SINGLE PHASE, 60 Hz

APPROX. WT. : 350 lbs

ROOM HEAT LOAD: 1570 BTU/HR

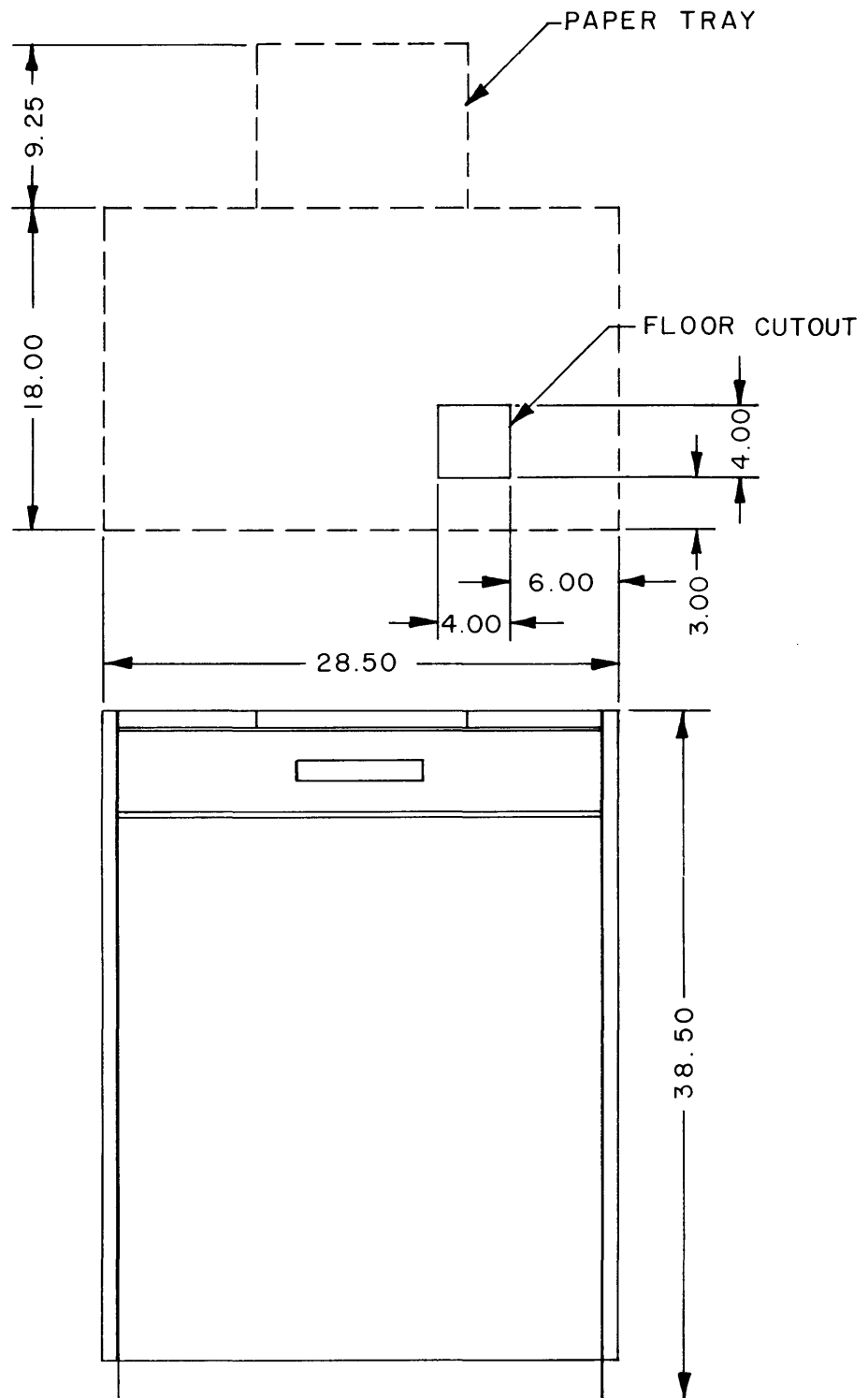

**PRINTER
CRAY I MCU**

POWER REQ'D: 115 VAC, 1Ø, 60Hz, 15A CIRCUIT

WEIGHT: 195 lbs

ROOM HEAT LOAD: 2000 BTU/HR

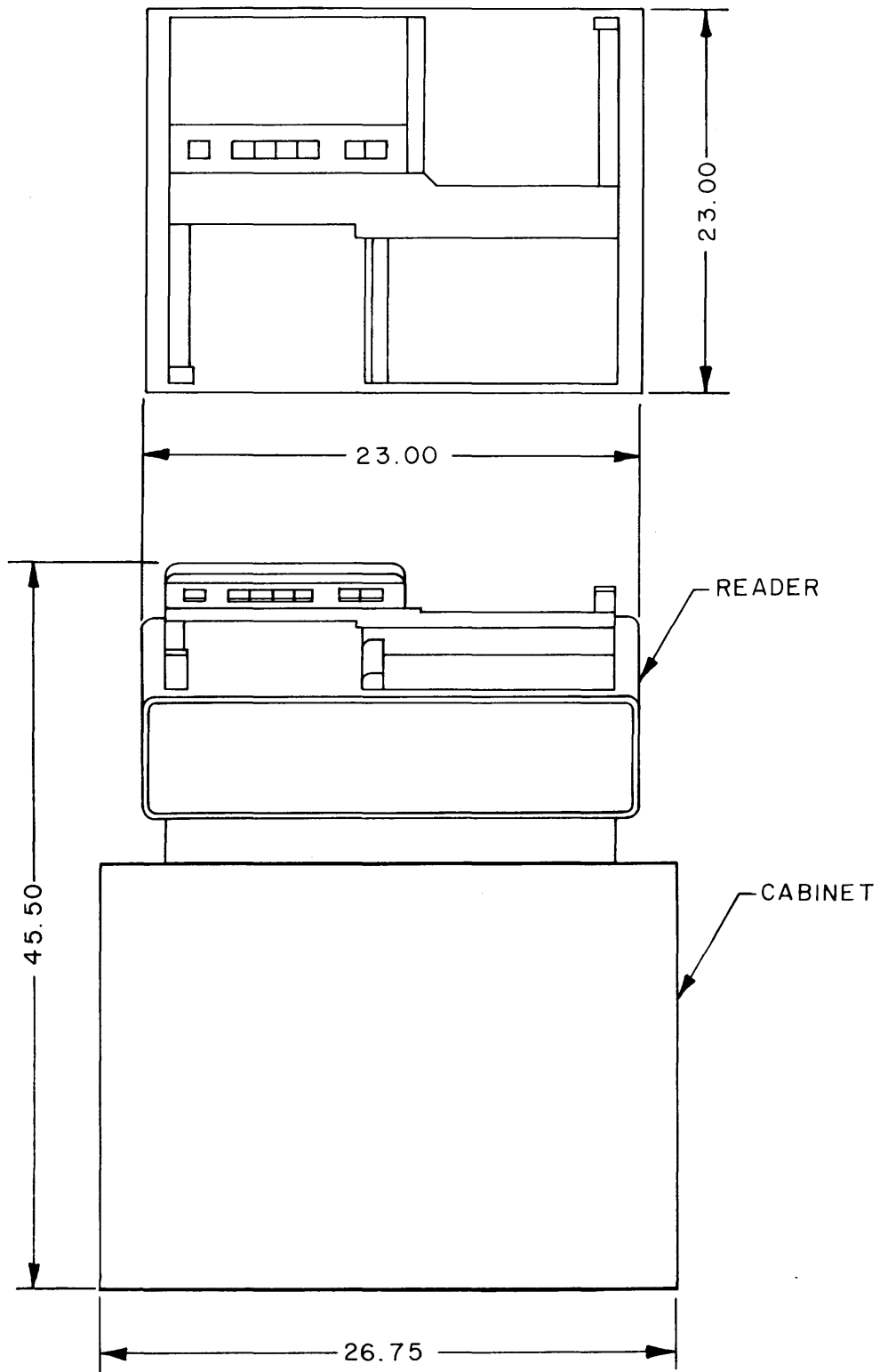

**CARD READER
CRAY I MCU**

POWER REQ'D: 115 VAC, 1Ø, 60 Hz, 15 AMP CIRCUIT

WEIGHT: 160 lbs

ROOM HEAT LOAD: 2050 BTU/HR(MAX)

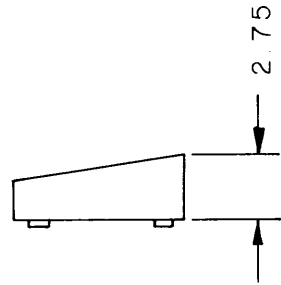
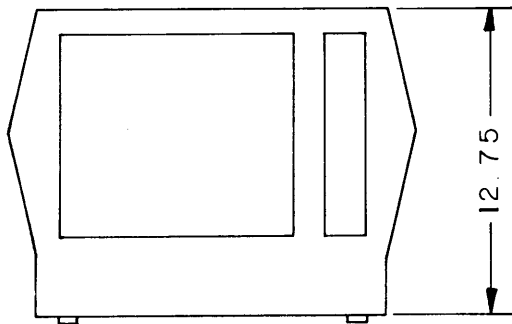
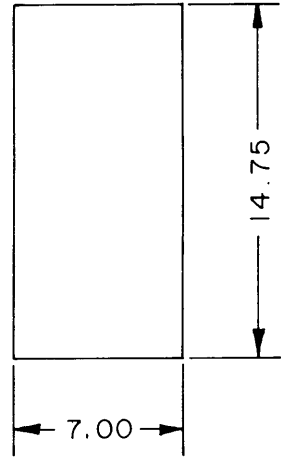
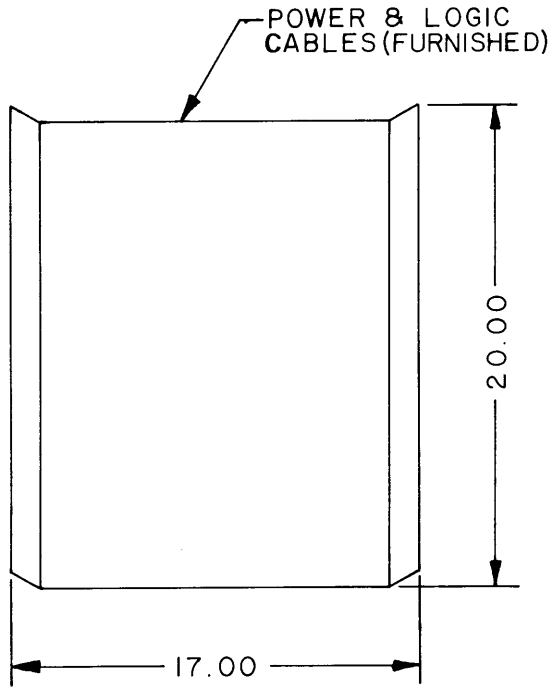

KEYBOARD

DISPLAY

**DISPLAY TERMINAL
CRAY I MCU**

POWER REQ'D: 115 V, 60 Hz, 15 A CIRCUIT

HEAT DISSIPATION: 350 BTU/HR

REVISIONS				
REV.	ECO.	DESCRIPTION	DRFT.	APP'D

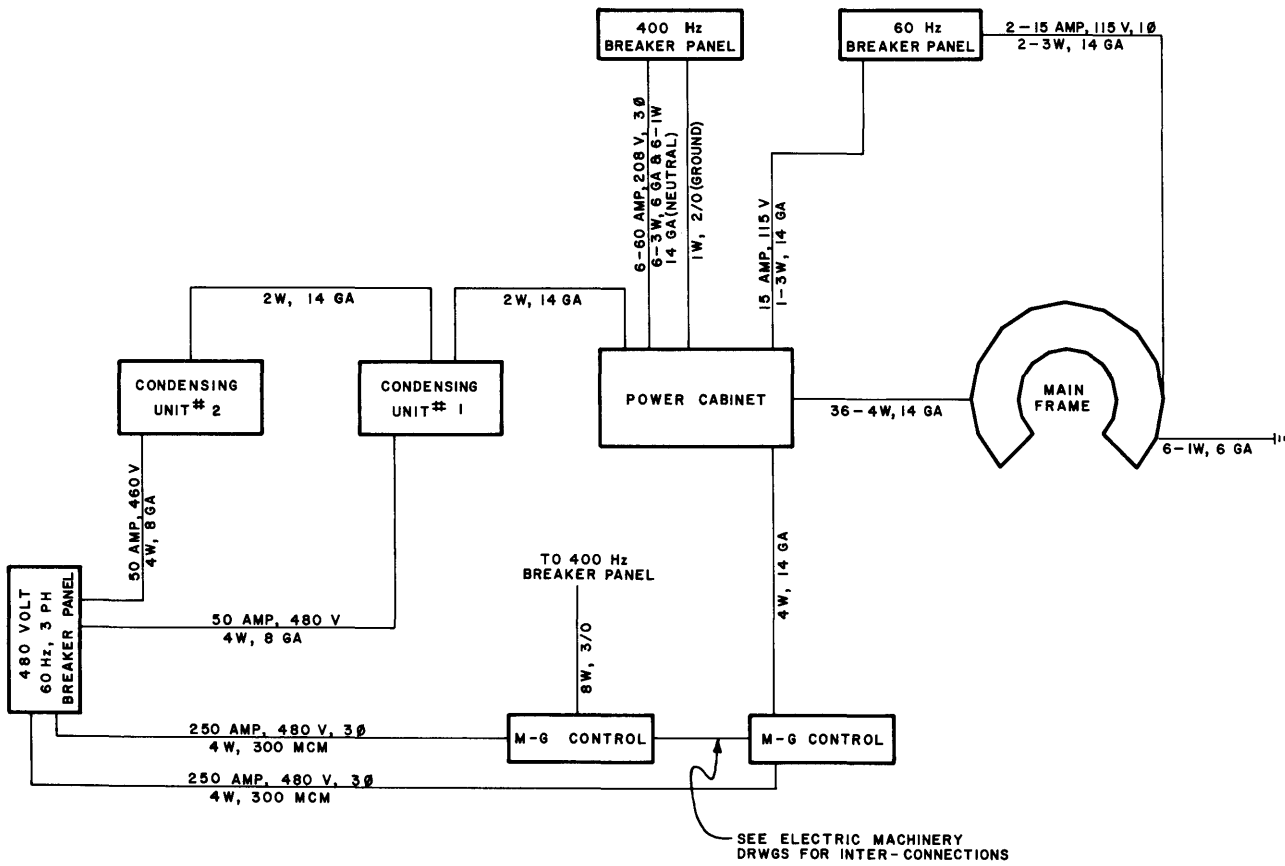

PART NUMBER	REV.

NOTE:
 1. WIRE SIZES SHOWN MAY BE CHANGED DEPENDING UPON LOCAL CODES, WIRE INSULATION USED AND LENGTH OF RUNS.

ITEM	REQ'D	PART NUMBER	DESCRIPTION	MATERIAL
LIST OF MATERIAL				

MATERIAL FINISH REMOVE ALL BURRS BREAK SHARP EDGES & CORNERS DO NOT SCALE	CRAY RESEARCH INCORPORATED		TITLE POWER WIRE SCHEMATIC (COMPUTER INSTALLATION)	
	PROJECT C R A Y - 1		TOLERANCES (EXCEPT AS NOTED)	
	DRWN <i>[Signature]</i>	DATE 5/6/73	FRAC. — ±	PREFIX SIZE PART NUMBER REV.
	CHK'D		DEC. — ±	C
APP.		ANG. — ±	SCALE WEIGHT SHEET OF	

REVISIONS					
REV.	ECO.	DESCRIPTION	DRFT.	DATE	APP'D

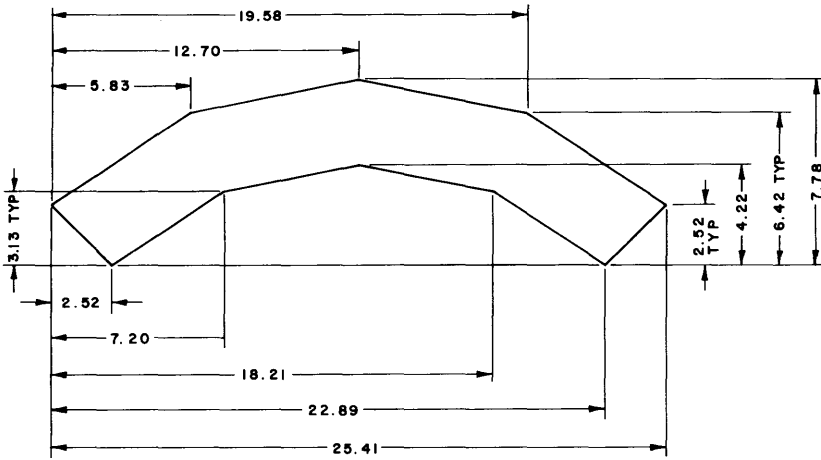

DETAIL "A"

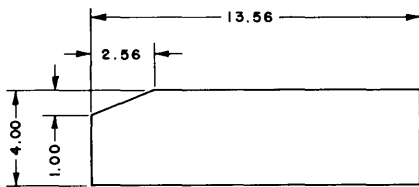

DETAIL "B"
(TYP 6 PLCS)

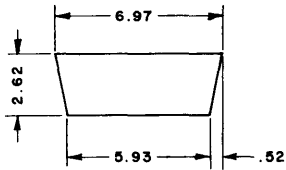

DETAIL "C"

NOTE:
1. DO NOT EDGE FLOOR CUTOUTS UNLESS EDGING IS FLUSH OR BELOW FLOOR SURFACE.

ITEM	REQ'D	PART NUMBER	DESCRIPTION	MATERIAL
------	-------	-------------	-------------	----------

LIST OF MATERIAL

PART NUMBER	REV
-------------	-----

MATERIAL	FINISH
REMOVE ALL BURRS BREAK SHARP EDGES & CORNERS	DO NOT SCALE

CRAY RESEARCH INCORPORATED	
PROJECT CRAY - 1	TOLERANCES (EXCEPT AS NOTED)
BY DATE	FRAC. — ±
DRWN CHK'D	DEC. — ± .12
APP.	ANG. — ±

TITLE FLOOR CUTOUTS MAIN FRAME SERIAL 2 & UP			
PREFIX	SIZE	PART NUMBER	REV.
D			
SCALE	WEIGHT	SHEET	OF
1/8			

REVISIONS

REV.	ECO.	DESCRIPTION	DRFT.	DATE	APP'D
------	------	-------------	-------	------	-------

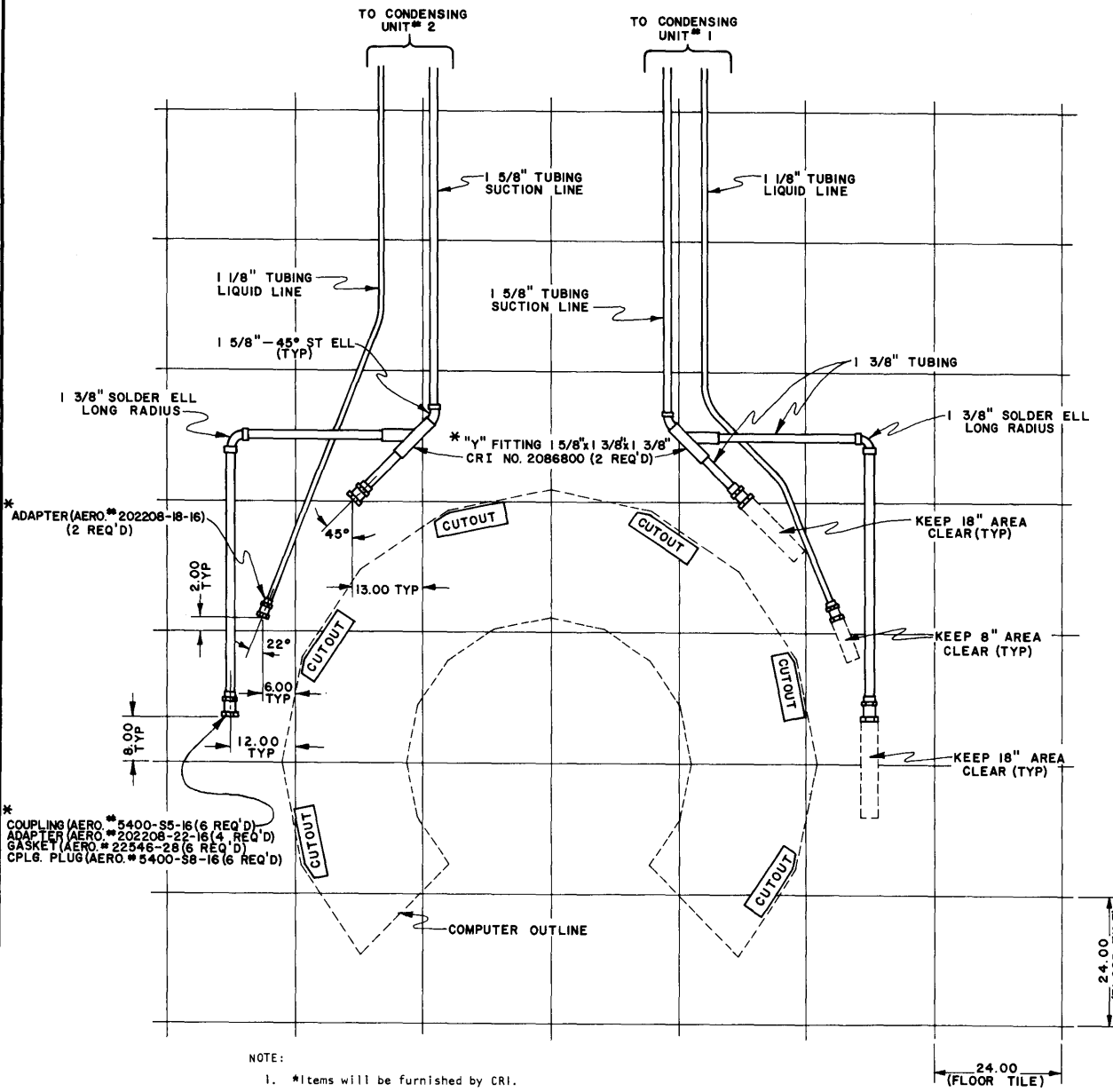

- * ADAPTER (AERO. # 202208-18-16) (2 REQ'D)
- * COUPLING (AERO. # 5400-35-16) (6 REQ'D)
- * ADAPTER (AERO. # 202208-22-16) (4 REQ'D)
- * GASKET (AERO. # 22546-28) (6 REQ'D)
- * CPLG. PLUG (AERO. # 5400-38-16) (6 REQ'D)

CUTOUT

CUTOUT

CUTOUT

CUTOUT

CUTOUT

CUTOUT

NOTE:

1. *Items will be furnished by CRI.
2. All connections to be made with silver solder.
3. Good refrigeration practices to be used--especially cleanliness.
4. System to be pumped down and hold 500 microns of vacuum.
5. System to be charged with R-22 and nitrogen to 300 PSI and leak tested with a detector with sensitivity of 1/2 oz per year or less.
6. Reevacuate system and add R-22 holding charge.
7. Piping arrangement may change--depending upon condensing unit location with respect to mainframe.
8. Specific site drawings will be furnished by CRI. These to include all refrigeration piping between mainframe and condensing units.

PART NUMBER	REV.
-------------	------

ITEM	REQ'D	PART NUMBER	DESCRIPTION	MATERIAL
------	-------	-------------	-------------	----------

LIST OF MATERIAL

MATERIAL	CRAY RESEARCH INCORPORATED		TITLE				
			-INSTALLATION- UNDER FLOOR REFRIG. FOR 1/2-FULL MEMORY COMPUTER				
FINISH	PROJECT	TOLERANCES (EXCEPT AS NOTED)		PREFIX	SIZE	PART NUMBER	REV.
REMOVE ALL BURRS	BY	DATE	FRAC. — ±	C			
BREAK SHARP EDGES & CORNERS	CHK'D		DEC. — ±				
DO NOT SCALE	APP.		ANG. — ±	SCALE	1/16	WEIGHT	SHEET
							OF



GENERAL OFFICE • P.O. Box 169, Chippewa Falls, WI 54729 • (715) 723-0266
SALES OFFICE • 7850 Metro Parkway, Suite 213, Minneapolis, MN 55420 • (612) 854-7472