

CRAY

RESEARCH, INC.

Any shipment to a country outside of the United States requires a U.S. Government export license.

CRAY COMPUTER SYSTEMS

**CRAY X-MP SERIES
MODELS 22 & 24
MAINFRAME REFERENCE MANUAL
HR-0032**

Copyright© 1982, 1984 by CRAY RESEARCH, INC. This manual or parts thereof may not be reproduced in any form without permission of CRAY RESEARCH, INC.

Each time this manual is revised and reprinted, all changes issued against the previous version in the form of change packets are incorporated into the new version and the new version is assigned an alphabetic level. Between reprints, changes may be issued against the current version in the form of change packets. Each change packet is assigned a numeric designator, starting with 01 for the first change packet of each revision level.

Every page changed by a reprint or by a change packet has the revision level and change packet number in the lower righthand corner. Changes to part of a page are noted by a change bar along the margin of the page. A change bar in the margin opposite the page number indicates that the entire page is new; a dot in the same place indicates that information has been moved from one page to another, but has not otherwise changed.

Requests for copies of Cray Research, Inc. publications and comments about these publications should be directed to:

CRAY RESEARCH, INC.,
1440 Northland Drive,
Mendota Heights, Minnesota 55120

<u>Revision</u>	<u>Description</u>
	November, 1982 - Original printing.
A	July, 1984 - Reprint with revision. Instructions were added for hardware performance monitoring and SECDDED maintenance functions. Information was also added to explain how the Second Vector Logical functional unit is used although this functional unit is not available on all systems. Numerous technical and editorial changes and corrections were also made. This revision obsoletes all previous printings.

PREFACE

This publication describes the functions of CRAY X-MP Series dual-processor computer systems, models 22 and 24. It is written to assist programmers and engineers and assumes a familiarity with digital computers.

The manual describes the overall computer system, its configurations, and equipment. It also describes the operation of the Central Processing Units that execute instructions, provide memory protection, report hardware exceptions, and provide interprocessor communications within the computer systems.

Details of the I/O Subsystem, the disk storage units, and the Solid-state Storage Device are given in the following publications:

- HR-0030 I/O Subsystem Hardware Reference Manual
- HR-0630 Mass Storage Subsystem Hardware Reference Manual
- HR-0031 Solid-state Storage Device (SSD®) Reference Manual

////////////////////////////////////

WARNING

This equipment generates, uses, and can radiate radio frequency energy and if not installed and used in accordance with the instructions manual, may cause interference to radio communications. It has been tested and found to comply with the limits for a Class A computing device pursuant to Subpart J of Part 15 of FCC Rules, which are designed to provide reasonable protection against such interference when operated in a commercial environment. Operation of this equipment in a residential area is likely to cause interference in which case the user at his own expense will be required to take whatever measures may be required to correct the interference.

////////////////////////////////////

CONTENTS

<u>PREFACE</u>	iii
1. <u>SYSTEM DESCRIPTION</u>	1-1
INTRODUCTION	1-1
CONVENTIONS	1-4
Italics	1-4
Register conventions	1-4
Number conventions	1-4
Clock period	1-4
SYSTEM COMPONENTS	1-5
Central Processing Units	1-5
Interfaces	1-7
I/O Subsystem	1-9
Disk storage units.	1-11
Solid-state Storage Device	1-12
Condensing units	1-13
Power distribution units	1-14
Motor-generator units	1-15
SYSTEM CONFIGURATION	1-16
2. <u>CPU SHARED RESOURCES</u>	2-1
INTRODUCTION	2-1
CENTRAL MEMORY	2-1
Memory organization	2-2
Memory addressing	2-3
Memory addressing for 6-column mainframe	2-3
Memory addressing for 12-column mainframe	2-4
Memory access	2-4
Conflict resolution	2-7
Bank Busy conflict	2-7
Simultaneous Bank conflict	2-7
Section Access conflict	2-7
Memory access priorities	2-7
16-bank phasing	2-8
Memory error correction	2-8
INTER-CPU COMMUNICATION SECTION	2-10
Real-time clock	2-10
Inter-CPU communication and control	2-11
Shared Address and Shared Scalar registers	2-12
Semaphore registers	2-12

2. CPU SHARED RESOURCES (continued)

CPU INPUT/OUTPUT SECTION	2-14
Data transfer for Solid-state Storage Device	2-15
Data transfer for I/O Subsystem	2-16
6 Mbyte per second channels	2-16
Multi-CPU programming	2-17
6 Mbyte per second channel operation	2-18
Input channel programming	2-19
Input channel error conditions	2-20
Output channel programming	2-20
Programmed master clear to external device	2-21
Memory access	2-21
I/O lockout	2-24
Memory bank conflicts	2-24
I/O memory conflicts	2-24
I/O memory request conditions	2-25
I/O memory addressing	2-25

3. CPU CONTROL SECTION 3-1

INTRODUCTION	3-1
INSTRUCTION ISSUE AND CONTROL	3-1
Program Address register	3-2
Next Instruction Parcel register	3-2
Current Instruction Parcel register	3-2
Lower Instruction Parcel register	3-3
Instruction buffers	3-3
EXCHANGE MECHANISM	3-5
Exchange Package	3-5
Processor number	3-7
Vector not used (VNU)	3-7
Enable second vector logical (ESVL)	3-8
Memory error data	3-8
Exchange registers	3-9
Exchange Address register	3-9
Mode register	3-9
Flag register	3-11
Cluster Number register	3-12
Program State register	3-12
A registers	3-12
S registers	3-12
Program Address register	3-13
Memory field registers	3-13
Active Exchange Package	3-13
Exchange sequence	3-13
Exchange initiated by deadstart sequence	3-14
Exchange initiated by Interrupt flag set	3-14
Exchange initiated by program exit	3-14
Exchange sequence issue conditions	3-15
Exchange Package management	3-15

3. CPU CONTROL SECTION (continued)

MEMORY FIELD PROTECTION	3-16
Instruction Base Address register	3-17
Instruction Limit Address register	3-17
Data Base Address register	3-18
Data Limit Address register	3-18
Program range error	3-18
Operand range error	3-19
PROGRAMMABLE CLOCK	3-19
Instructions	3-19
Interrupt Interval register	3-19
Interrupt Countdown counter	3-20
Clear programmable clock interrupt request	3-20
PERFORMANCE MONITOR	3-20
DEADSTART SEQUENCE	3-21

4. CPU COMPUTATION SECTION

INTRODUCTION	4-1
OPERATING REGISTERS	4-3
ADDRESS REGISTERS	4-3
A registers	4-3
B registers	4-5
SCALAR REGISTERS	4-6
S registers	4-6
T registers	4-8
VECTOR REGISTERS	4-9
V registers	4-9
V register reservations and chaining	4-12
Vector control registers	4-13
Vector Length register	4-13
Vector Mask register	4-13
FUNCTIONAL UNITS	4-14
Address functional units	4-14
Address Add functional unit	4-15
Address Multiply functional unit	4-15
Scalar functional units	4-15
Scalar Add functional unit	4-15
Scalar Shift functional unit	4-16
Scalar Logical functional unit	4-16
Scalar Population/Parity/Leading Zero functional unit	4-16
Vector functional units	4-16
Vector functional unit reservation	4-17
Vector Add functional unit	4-17
Vector Shift functional unit	4-17
Full Vector Logical functional unit	4-18
Second Vector Logical functional unit	4-18
Vector Population/Parity functional unit	4-19

FUNCTIONAL UNITS (continued)

Floating-point functional units	4-20
Floating-point Add functional unit	4-20
Floating-point Multiply functional unit	4-20
Reciprocal Approximation functional unit	4-21
ARITHMETIC OPERATIONS	4-21
Integer arithmetic	4-21
Floating-point arithmetic	4-22
Normalized floating-point numbers	4-23
Floating-point range errors	4-24
Floating-point Add functional unit	4-24
Floating-point Multiply functional unit	4-25
Floating-point Reciprocal Approximation functional unit	4-27
Double-precision numbers	4-27
Addition algorithm	4-27
Multiplication algorithm	4-28
Division algorithm	4-30
Newton's method	4-30
Derivation of the division algorithm	4-31
LOGICAL OPERATIONS	4-35

5. <u>CPU INSTRUCTIONS</u>	5-1
INSTRUCTION FORMAT	5-1
1-parcel instruction format with discrete j and k fields	5-1
1-parcel instruction format with combined j and k fields	5-2
2-parcel instruction format with combined $j, k,$ and m fields	5-2
2-parcel instruction format with combined $i, j, k,$ and m fields	5-3
SPECIAL REGISTER VALUES	5-4
INSTRUCTION ISSUE	5-5
INSTRUCTION DESCRIPTIONS	5-6

APPENDIX SECTION

A. <u>INSTRUCTION SUMMARY FOR CRAY X-MP MODELS 22 AND 24</u>	A-1
B. <u>6 MBYTE PER SECOND CHANNEL DESCRIPTIONS</u>	B-1
INTRODUCTION	B-1
6 MBYTE PER SECOND INPUT CHANNEL SIGNAL SEQUENCE	B-1
Data bits 2^0 through 2^{15}	B-1
Parity bits 0 through 3	B-2

6 MBYTE PER SECOND INPUT CHANNEL SIGNAL SEQUENCE (continued)	
Ready signal	B-3
Resume signal	B-3
Disconnect signal	B-3
6 MBYTE PER SECOND OUTPUT CHANNEL SIGNAL SEQUENCE	
Data bits 2 ⁰ through 2 ¹⁵	B-4
Parity bits 0 through 3	B-5
Ready signal	B-5
Resume signal	B-5
Disconnect signal	B-5

C. <u>PERFORMANCE MONITOR</u>	C-1
INTRODUCTION	C-1
SELECTING PERFORMANCE EVENTS	C-1
READING PERFORMANCE RESULTS	C-3
TESTING PERFORMANCE COUNTERS	C-3
D. <u>SECDED MAINTENANCE FUNCTIONS</u>	D-1
INTRODUCTION	D-1
VERIFICATION OF CHECK BIT STORAGE	D-1
VERIFICATION OF CHECK BIT GENERATION	D-2
VERIFICATION OF ERROR DETECTION AND CORRECTION	D-2
CLEARING MAINTENANCE MODE FUNCTIONS	D-3

FIGURES

1-1	CRAY X-MP Model 22 or 24 12-column mainframe with a Cray I/O Subsystem and an SSD	1-2
1-2	Basic organization of the dual-processor system	1-5
1-3	Control and data paths for a single CPU	1-6
1-4	CRAY X-MP Models 22 or 24 6-column mainframe chassis	1-7
1-5	Typical interface cabinet	1-8
1-6	I/O Subsystem chassis	1-10
1-7	DD-29 Disk Storage Unit	1-11
1-8	Solid-state Storage Device chassis	1-12
1-9	Condensing unit	1-13
1-10	Power distribution units	1-14
1-11	Motor-generator equipment	1-15
1-12	Block diagram of CRAY X-MP dual-processor system with full disk capacity	1-16
1-13	Block diagram of CRAY X-MP dual-processor system with block multiplexer channels	1-17
2-1	Central Memory organization for a dual-processor system	2-2
2-2	6-column memory address (32 banks)	2-3
2-3	6-column memory address (16 banks)	2-3
2-4	12-column memory address (32 banks)	2-4

FIGURES (continued)

2-5	12-column memory address (16 banks)	2-4
2-6	Memory data path with SECEDED	2-8
2-7	Error correction matrix	2-9
2-8	Shared registers and real-time clock	2-11
2-9	Basic I/O program flowchart	2-19
2-10	Channel I/O control (shown for one processor)	2-22
2-11	Input/output data paths	2-23
3-1	Instruction issue and control elements	3-1
3-2	Instruction buffers	3-3
3-3	Exchange Package for a dual-processor system	3-6
4-1	Address registers and functional units	4-4
4-2	Scalar registers and functional units	4-7
4-3	Vector registers and functional units	4-10
4-4	Integer data formats	4-22
4-5	Floating-point data format	4-23
4-6	Exponent matrix for Floating-point Multiply unit	4-25
4-7	Integer multiply in Floating-point Multiply functional unit	4-27
4-8	49-bit floating-point addition	4-28
4-9	Floating-point multiply partial-product sums pyramid	4-29
4-10	Newton's method	4-31
5-1	General form for instructions	5-1
5-2	1-parcel instruction format with discrete j and k fields	5-2
5-3	1-parcel instruction format with combined j and k fields	5-2
5-4	2-parcel instruction format with combined j , k , and m fields	5-3
5-5	2-parcel instruction format for a branch with combined i , j , k , and m fields	5-4
5-6	2-parcel instruction format for a 24-bit immediate constant with combined i , j , k , and m fields	5-4
5-7	Vector left double shift, first element, VL greater than 1	5-71
5-8	Vector left double shift, second element, VL greater than 2	5-71
5-9	Vector left double shift, last element	5-71
5-10	Vector right double shift, first element	5-72
5-11	Vector right double shift, second element, VL greater than 1	5-73
5-12	Vector right double shift, last operation	5-73

TABLES

1-1	CRAY X-MP dual-processor system characteristics	1-3
2-1	Access conflicts to shared registers in a dual-processor computer	2-13
2-2	Channel word assembly/disassembly	2-18
3-1	Exchange Package assignments	3-7

TABLES (continued)

B-1	Input channel signal exchange	B-2
B-2	Output channel signal exchange	B-4
C-1	Performance counter group descriptions	C-2

INDEX

SYSTEM DESCRIPTION

1

INTRODUCTION

The CRAY X-MP/22 and CRAY X-MP/24 are powerful, general purpose computer systems that contain two central processing units (CPUs). The systems can achieve extremely high multiprocessing rates by efficiently using the scalar and vector processing capabilities of both CPUs combined with the systems' random-access, solid-state memory (RAM) and shared registers.

Vector processing is the performance of iterative operations on sets of ordered data. When two or more vector operations are chained together, two or more operations can be executing each 9.5-nanosecond clock period, greatly exceeding the computational rates of conventional scalar processing. Scalar operations complement the vector capability by providing solutions to problems not readily adaptable to vector techniques.

Equipment options allow the systems to be configured for a particular use (see table 1-1). Central Memory of a dual-processor system can be either 2 million (model 22) or 4 million (model 24) 64-bit words. The systems are compatible with all existing models of the Cray I/O Subsystem, which matches the mainframe's processing rates with high input/output transfer rates for communication with mass storage units, other peripheral devices, and a wide variety of host computers.

In addition to the mainframe and I/O Subsystem, a Cray Research, Inc., Solid-state Storage Device can be configured with the system. An SSD provides significantly improved throughput of programs that access large data files repetitively. Figure 1-1 illustrates the mainframe configured with a Cray I/O Subsystem and an SSD®.

This section describes system components and configurations. Table 1-1 provides overall system characteristics.

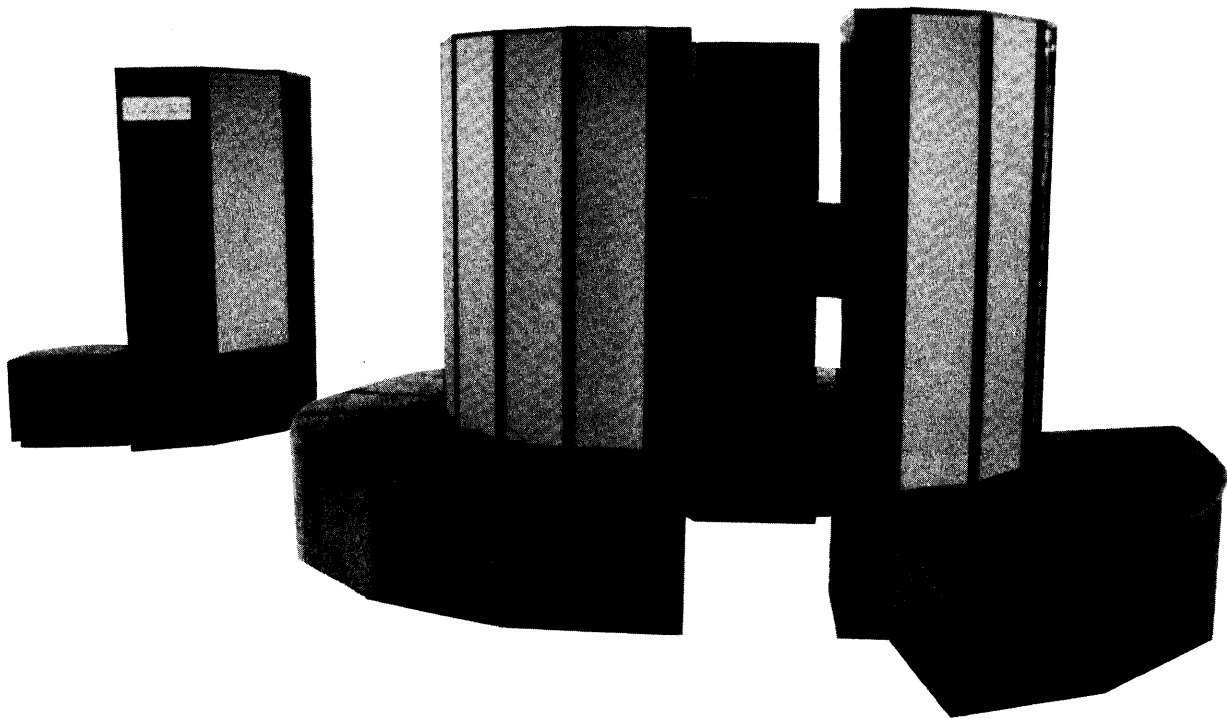

Figure 1-1. CRAY X-MP Model 22 or 24 12-column mainframe
with a Cray I/O Subsystem and an SSD

Table 1-1. CRAY X-MP dual-processor system characteristics

Configuration	<ul style="list-style-type: none"> - Mainframe with 2 Central Processing Units (CPUs) - I/O Subsystem with 2, 3, or 4 I/O Processors - Optional Solid-state Storage Device (SSD)
CPU speed	<ul style="list-style-type: none"> - 9.5 ns CPU clock period - 105 million floating-point additions per second per CPU - 105 million floating-point multiplications per second per CPU - 105 million half-precision floating-point divisions per second per CPU - 33 million full-precision floating-point divisions per second per CPU - Simultaneous floating-point addition, multiplication, and reciprocal approximation within each CPU
Memories	<ul style="list-style-type: none"> - Mainframe has 2 million (model 22) or 4 million (model 24) 64-bit words in Central Memory
Input/Output	<ul style="list-style-type: none"> - One 1250 Mbyte per second Solid-state Storage Device (SSD) channel pair - Two 100 Mbyte per second channel pairs for interface to I/O Subsystem - Four 6 Mbyte per second channel pairs
Physical	<ul style="list-style-type: none"> - 64 sq ft floor space for 12-column mainframe; 32 sq ft floor space for 6-column mainframe. - 15 sq ft floor space for I/O Subsystem - 15 sq ft floor space for SSD - 5.25 tons, 12-column mainframe weight; 2.95 tons, 6-column mainframe weight. - 1.5 tons, I/O Subsystem weight - 1.5 tons, SSD weight - Liquid refrigeration of each chassis - 400 Hz power from motor-generators

CONVENTIONS

The following conventions are used in this manual.

ITALICS

Italicized lowercase letters, such as *jk*, indicate variable information.

REGISTER CONVENTIONS

Parenthesized register names are used frequently in this manual as a form of shorthand notation for the expression "the contents of register ---." For example, "Branch to (P)" means "Branch to the address indicated by the contents of register P."

Designations for the A, B, S, T, and V registers are used extensively. For example, "Transmit (*T_{jk}*) to *S_i*" means "Transmit the contents of the T register specified by the *jk* designators to the S register specified by the *i* designator."

Register bits are numbered right to left as powers of 2, starting with 2^0 . Bit 2^{63} of an S, V, or T register value represents the most significant bit. Bit 2^{23} of an A or B register value represents the most significant bit. (A and B registers are 24 bits.) The numbering conventions for the Exchange Package and the Vector Mask register are exceptions. Bits in the Exchange Package are numbered from left to right and are not numbered as powers of 2 but as bits 0 through 63 with 0 as the most significant and 63 as the least significant. The Vector Mask register has 64 bits, each corresponding to a word element in a vector register. Bit 2^{63} corresponds to element 0, bit 2^0 corresponds to element 63.

NUMBER CONVENTIONS

Unless otherwise indicated, numbers in this manual are decimal numbers. Octal numbers are indicated with an 8 subscript. Exceptions are register numbers, channel numbers, instruction parcels in instruction buffers, and instruction forms which are given in octal without the subscript.

CLOCK PERIOD

The basic unit of CPU computation time is 9.5 nanoseconds (ns) and is referred to as a clock period (CP). Instruction issue, memory references, and other timing considerations are often measured in CPs.

SYSTEM COMPONENTS

The system is composed of a mainframe and an I/O Subsystem. Mass storage devices, front-end interfaces, and optional tape devices are also integral parts of a system. Optionally, a Cray Solid-state Storage Device (SSD) can be part of the system. Supporting this equipment are condensing units for refrigeration, motor-generators to provide system power, and power distribution units for the mainframe, I/O Subsystem, and the SSD. System components are described on the following pages.

CENTRAL PROCESSING UNITS

Each CPU has independent control and computation sections. Both CPUs share Central Memory and the inter-CPU communication and I/O sections. (CPU sections are described in later sections.) Figure 1-2 illustrates the basic organization of the computer; figure 1-3 illustrates the components and control and data paths of a single CPU in the system. Figure 1-4 shows mainframe chassis.

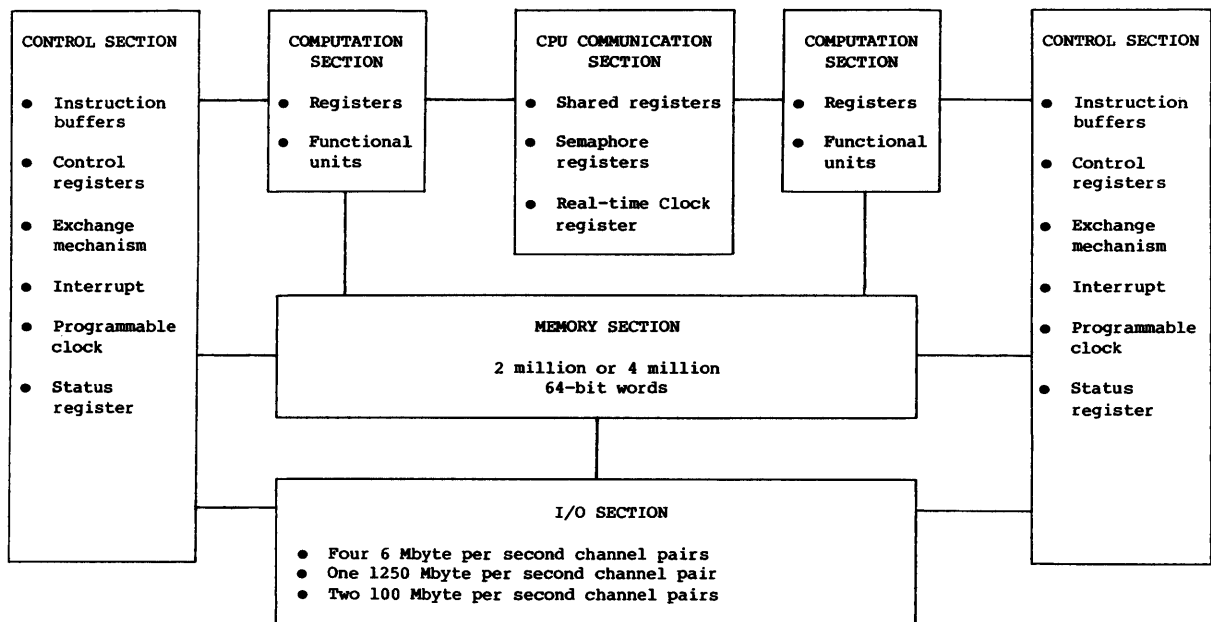

Figure 1-2. Basic organization of the dual-processor system

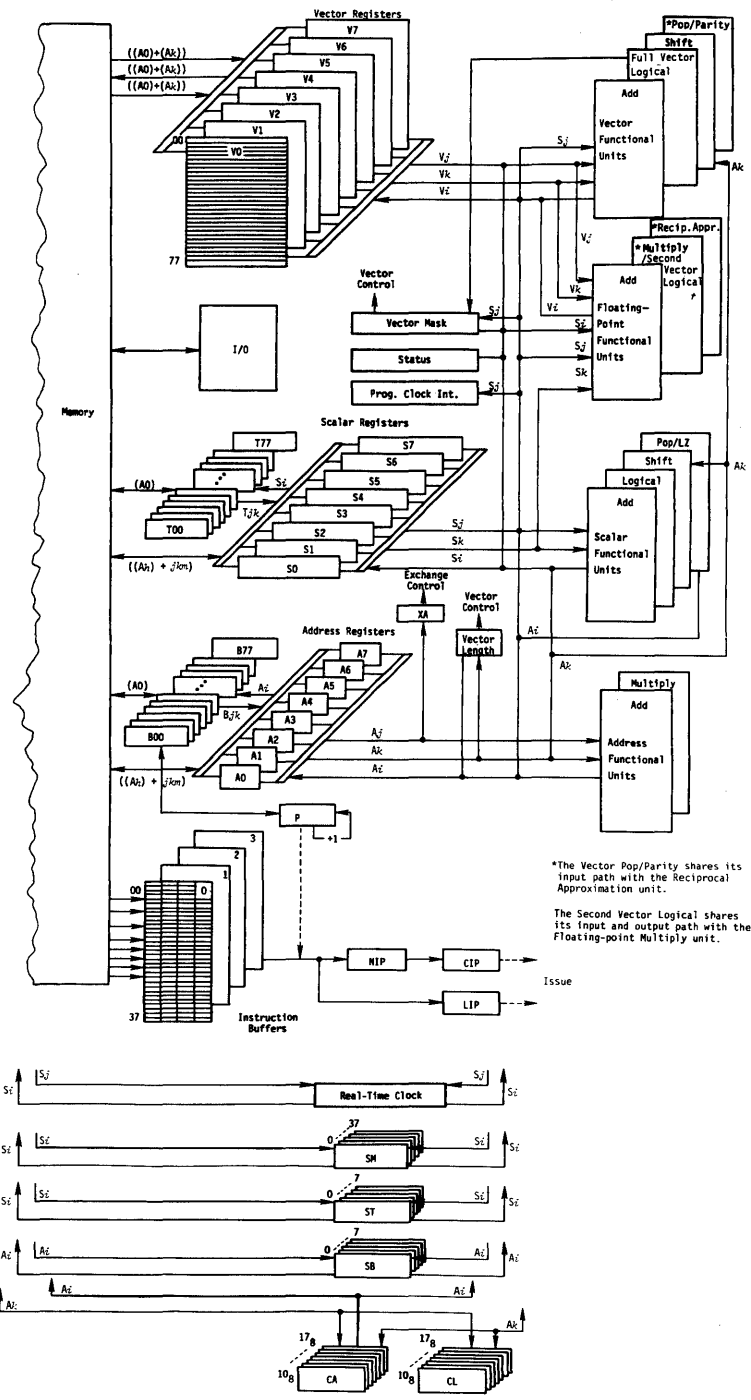

Figure 1-3. Control and data paths for a single CPU

† Second Vector Logical unit not available on all machines.



Figure 1-4. CRAY X-MP Model 22 or 24 6-column mainframe chassis

INTERFACES

The Cray mainframe is designed for use with front-end computers in a computer network. A front-end computer system is self contained and executes under the control of its own operating system.

Standard interfaces connect the Cray mainframe's I/O channels to channels of front-end computers, providing input data to the Cray and receiving output from it for distribution to peripheral equipment. Interfaces compensate for differences in channel widths, machine word size, electrical logic levels, and control signals. The Master I/O Processor of the I/O Subsystem communicates with a front-end computer system through a 6 Mbyte per second channel pair to a channel adapter module in the Cray mainframe. Communication continues through a front-end interface, to the front-end computer typically through a front-end computer I/O channel.

The front-end interface is housed in a stand-alone cabinet (figure 1-5) located near the host computer. Its operation is invisible to both the front-end computer user and the Cray user.

A primary goal of the interface is to maximize the use of the front-end channel connected to the Cray system. Since the MIOP channel connected to the interface is faster than any front-end channel connected to the interface, the burst rate of the interface is limited by the maximum rate of the front-end channel.

Interfaces to front-end computers allow the front-end computers to service the Cray mainframe in the following ways:

- As a master operator station
- As a local operator station
- As a local batch entry station
- As a data concentrator for multiplexing several other stations into a single Cray channel
- As a remote batch entry station
- As an interactive communication station

Peripheral equipment attached to the front-end computer varies depending on the use of the Cray system.



Figure 1-5. Typical interface cabinet

I/O SUBSYSTEM

The I/O Subsystem, shown in figure 1-6, is standard on all models of CRAY X-MP Computer Systems and has two, three, or four I/O Processors (IOPs), a Buffer Memory, and required interfaces. It is designed for fast data transfer between front-end computers, peripheral devices, storage devices, and the I/O Subsystem's Buffer Memory or between its Buffer Memory and the Central Memory of a Cray mainframe.

Four types of I/O Processors may be configured in an I/O Subsystem: a Master IOP (MIOP), a Buffer IOP (BIOP), a Disk IOP (DIOP) and an Auxiliary IOP (XIOP). All I/O Subsystems must have at least one MIOP and one BIOP. The number of DIOPs and XIOPs is site dependent.

Each IOP of the I/O Subsystem has a memory section, a control section, a computation section, and an input/output section. Input/output sections are independent and handle some portion of the I/O requirements for the Subsystem. Each IOP also has six direct memory access ports to its local Memory.

The Master I/O Processor (MIOP) controls the front-end interfaces and the standard group of station[†] peripherals. The Peripheral Expander interfaces the station peripherals to one direct memory access (DMA) port of the MIOP. The MIOP also connects to Buffer Memory and to the mainframe over a 6 Mbyte per second channel pair. The MIOP communicates with the Cray Operating System (COS) to coordinate the activities of the entire I/O Subsystem.

The Buffer I/O Processor (BIOP) is the main link between the mainframe's Central Memory and the mass storage devices. Data from mass storage is transferred through the BIOP's Local Memory to the mainframe's Central Memory through a 100 Mbyte per second channel pair.

The Disk I/O Processor (DIOP) is used for additional disk storage units. This processor can handle up to four disk controller units with up to 16 disk storage units. The DIOP uses one DMA port for each controller, one DMA port to connect to Buffer Memory, and another DMA port to connect a 100 Mbyte per second channel pair to the mainframe Central Memory.

The Auxiliary I/O Processor (XIOP) is used for block multiplexer channels and interfaces to a maximum of four BMC-4 Block Multiplexer Controllers. Each controller can handle up to four block multiplexer channels. The XIOP uses one DMA port for each controller and another DMA port to connect with Buffer Memory.

[†] The term station means both hardware and software. Station is the link to the front end or can act as a limited front end (as the MIOP).

I/O Subsystem hardware allows for simultaneous data transfers between the BIOP and DIOP or XIOP of the I/O Subsystem and the mainframe's Central Memory.[†]

The CPU input/output section for Cray dual-processor systems is described in section 2 of this manual. Refer to the I/O Subsystem Reference Manual, CRI publication HR-0030, for a complete description of the I/O Subsystem.

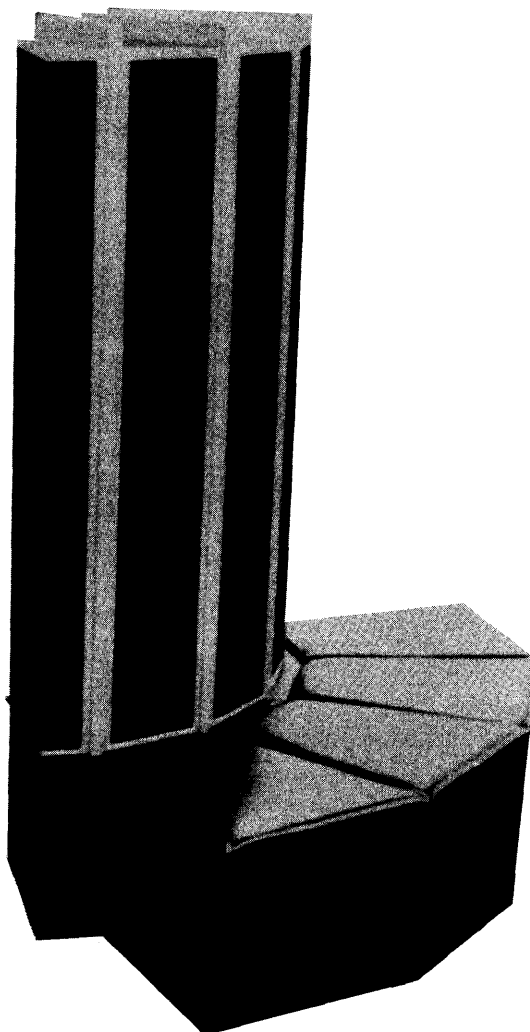

Figure 1-6. I/O Subsystem chassis

[†] Software to support the 100 Mbyte per second channel pair to the XIOP is currently not available.

DISK STORAGE UNITS

For mass storage, the system uses Cray Research, Inc., disk storage unit (DSUs). A disk controller unit (DCU) interfaces the disk storage units with an I/O Processor of an I/O Subsystem through one direct memory access (DMA) port. Up to four disk storage units can be connected to a single DCU.

The I/O Processor and the disk controller unit can transfer data between the DMA port and four DSUs with all DSUs operating at full speed without missing data or skipping revolutions. A minimum of 2 and a maximum of 48 DSUs can be configured on an I/O Subsystem. Figure 1-7 shows a Cray DD-29 Disk Storage Unit. The disk controller unit is housed in the I/O Subsystem chassis.

Each DSU has two accesses for connecting it to controllers. The second independent data path to each DSU exists through another Cray Research, Inc., controller. Reservation logic provides controlled access to each DSU. Dynamic sharing of devices is not supported by the Cray Operating System (COS) software. Further information about the mass storage subsystem is included in the I/O Subsystem Reference Manual, CRI publication HR-0030, and the Mass Storage Subsystem Hardware Reference Manual, CRI publication HR-0630.



Figure 1-7. DD-29 Disk Storage Unit

SOLID-STATE STORAGE DEVICE

The Solid-state Storage Device (SSD) shown in figure 1-8 is an optional, high-performance device used for temporary data storage. It transfers data between the mainframe's Central Memory and the SSD through a special Cray interface cable set at a maximum speed of 1250 Mbytes per second. The actual speed of these transfers is dependent on the SSD memory size and system configuration as described in the Solid-state Storage Device (SSD) Reference Manual, CRI publication HR-0031.



Figure 1-8. Solid-state Storage Device chassis

CONDENSING UNITS

Condensing units (figure 1-9) contain the major components of the refrigeration system used to cool the computer chassis and consist of two 25-ton condensers. Heat is removed from the condensing unit by a second level cooling system that is not part of the computer system. Freon, which cools the computer, picks up heat and transfers it to water in the condensing unit.

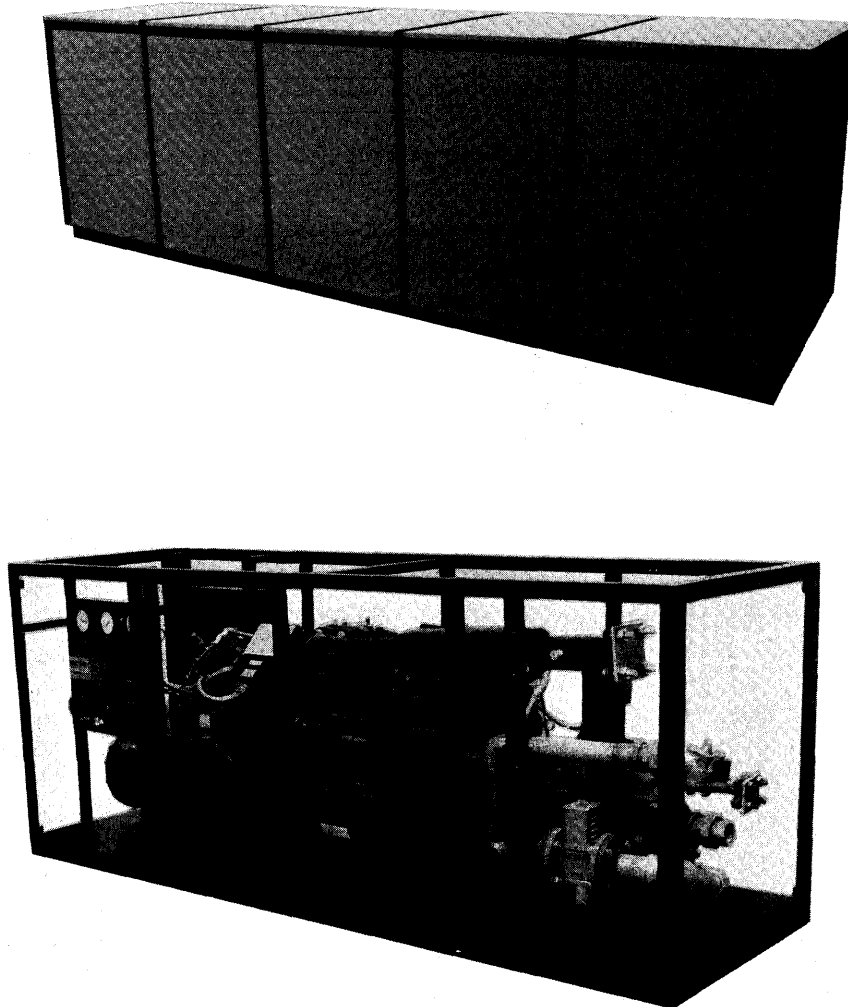

Figure 1-9. Condensing unit

POWER DISTRIBUTION UNITS

The Cray mainframe, I/O Subsystem, and SSD all operate from 400 Hz 3-phase power. The mainframe, I/O Subsystem, and SSD have independent power distribution units. The power distribution unit for the mainframe contains adjustable transformers for regulating the voltage to each column of the mainframe. The power distribution unit also contains temperature and voltage monitoring equipment that checks temperatures at strategic locations on the mainframe chassis. Automatic warning and shutdown circuitry protects the mainframe in case of overheating or excessive cooling. Control switches for the motor-generators and the condensing unit are also mounted on the mainframe's power distribution unit.

A smaller power distribution unit performs similar functions for the I/O Subsystem chassis or the SSD chassis.

Figure 1-10 shows the power distribution units for the mainframe (left) and for the I/O Subsystem or SSD (right).

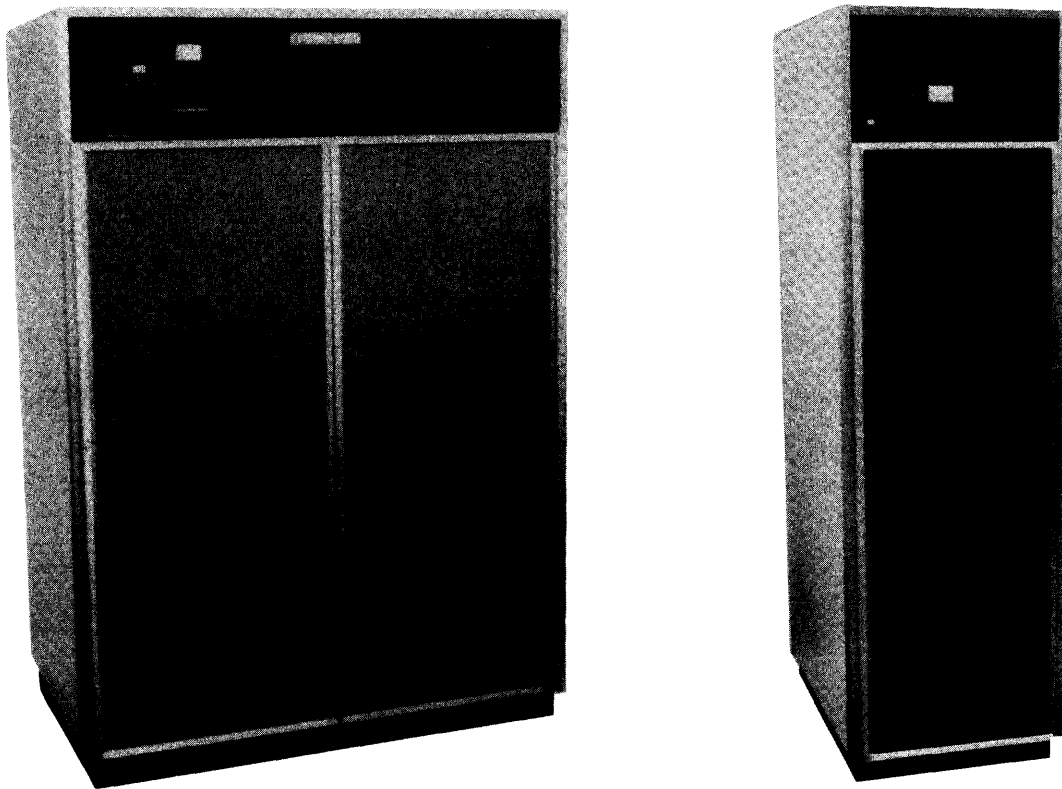

Figure 1-10. Power distribution units

MOTOR-GENERATOR UNITS

Motor-generator units convert primary power from the commercial power mains to the 400 Hz power used by the system. These units isolate the system from transients and fluctuations on the commercial power mains. The equipment consists of two or three motor-generator units and a control cabinet. Figure 1-11 shows a typical motor-generator and its control cabinet.

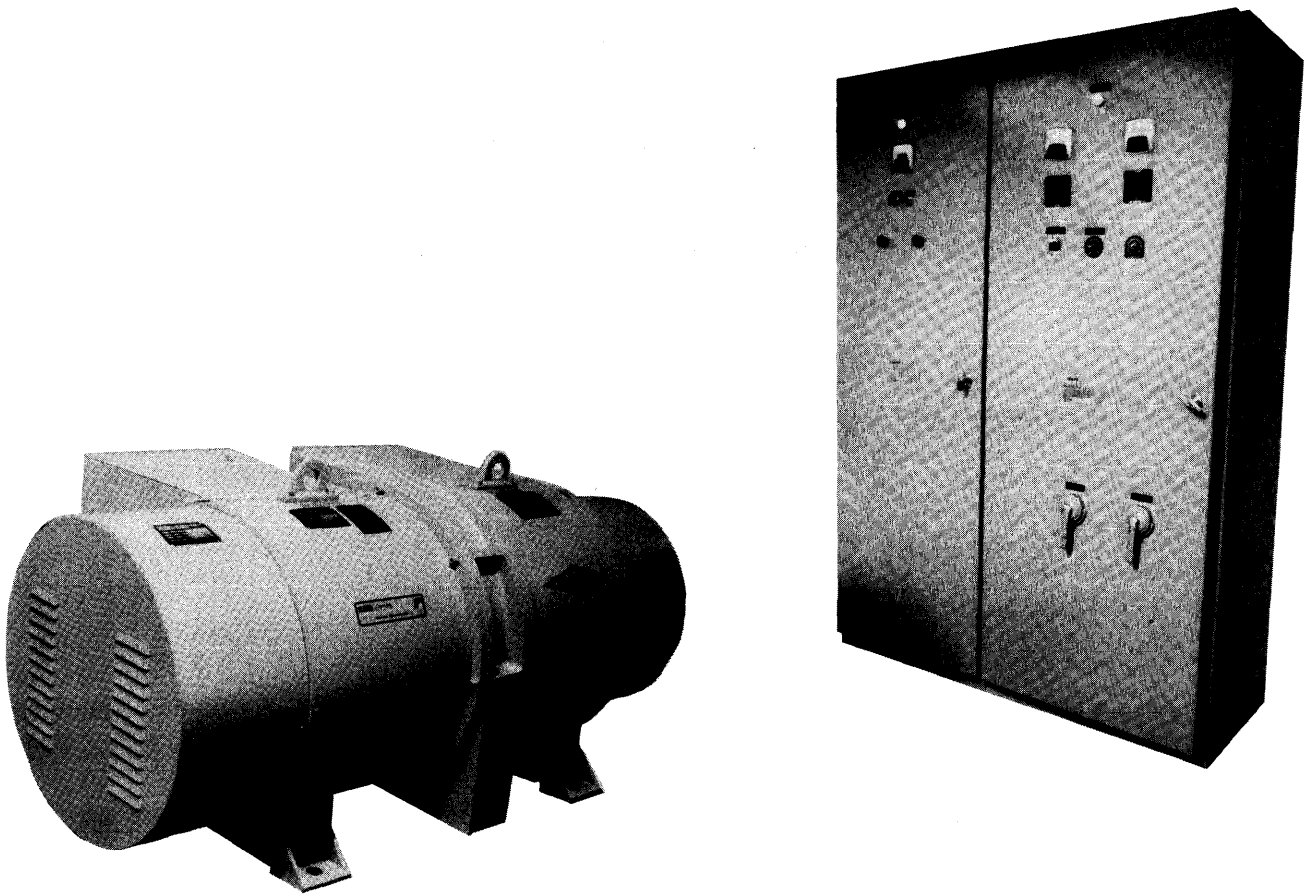

Figure 1-11. Motor-generator equipment

SYSTEM CONFIGURATION

Figures 1-12 and 1-13 illustrate two configurations for models 22 or 24 of the CRAY X-MP Computer System.

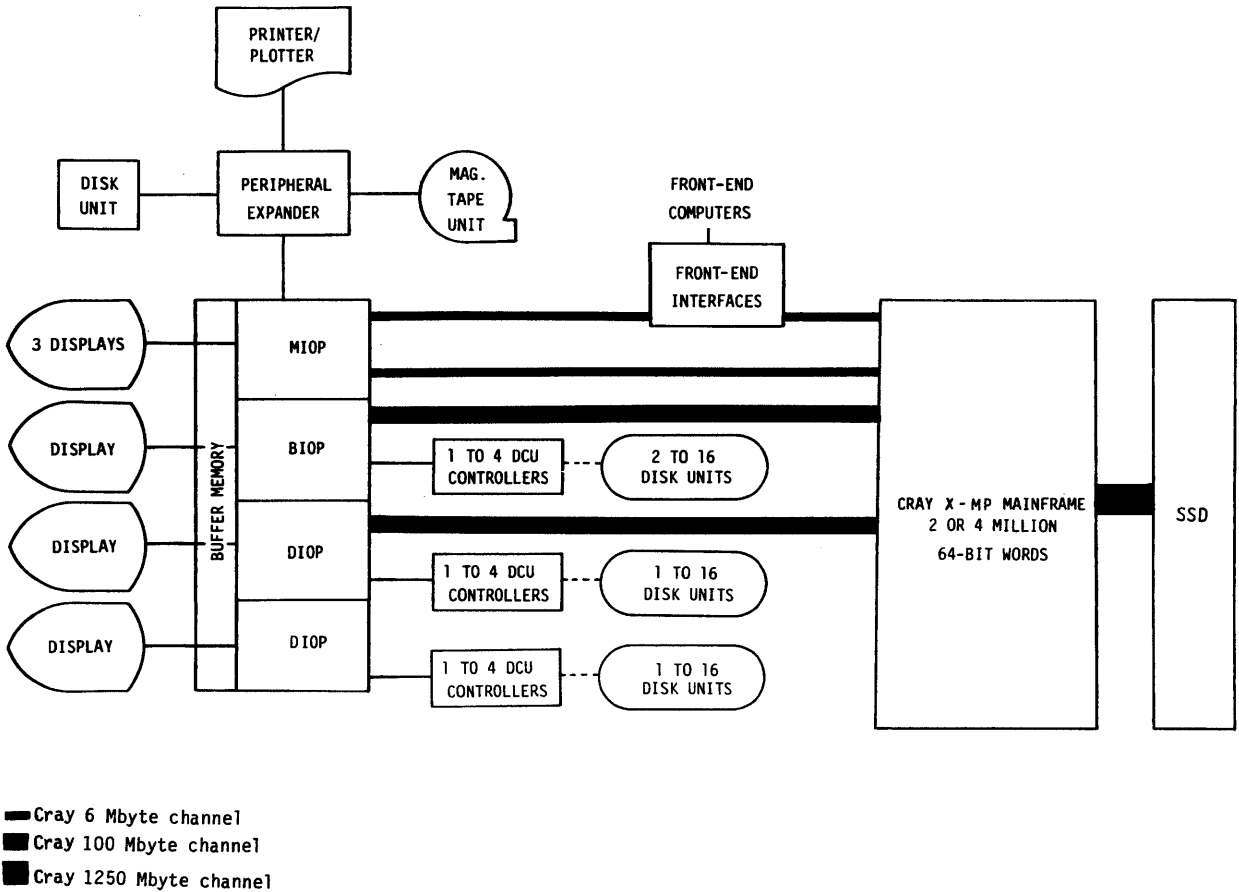

Figure 1-12. Block diagram of CRAY X-MP dual-processor system with full disk capacity

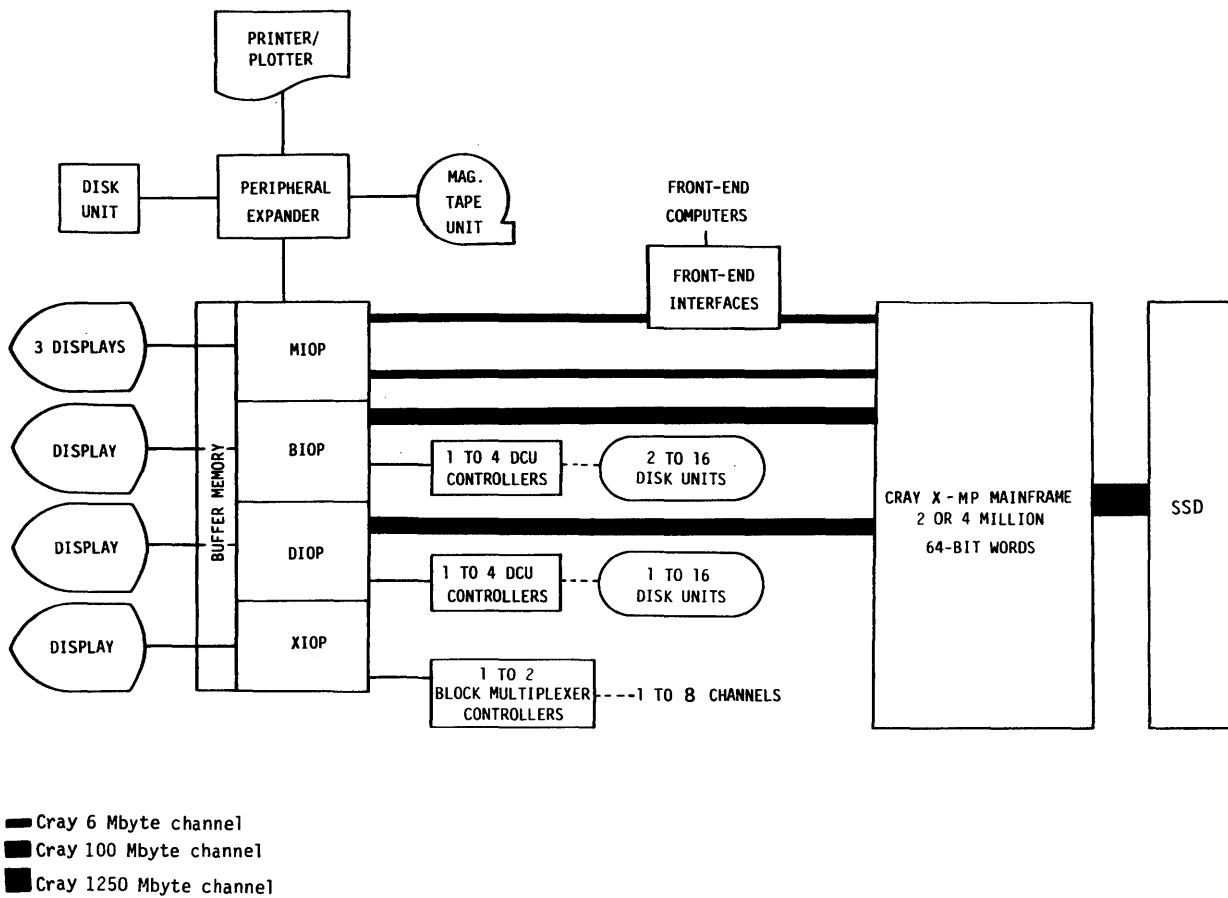

Figure 1-13. Block diagram of CRAY X-MP dual-processor system with block multiplexer channels

CPU SHARED RESOURCES

2

INTRODUCTION

Both Central Processing Units (CPUs) of a system share the mainframe's Central Memory, the inter-CPU communication section, and the input/output section. These areas common to the CPUs are described in the following pages.

CENTRAL MEMORY

Central Memory consists of a number of banks of solid-state, random access memory (RAM) and is shared by the CPUs and the I/O section. Standard Central Memory sizes are: 2 million words with 16 banks and 4 million words with 32 banks. Banks are independent of each other; sequentially addressed words reside in sequential banks. Each word is 72 bits with 64 data bits and 8 check bits.

Central Memory cycle time is 4 clock periods (CPs) or 38 nanoseconds (ns). Access time, the time required to fetch an operand from Central Memory to an operating register, is 14 CPs (133 ns) for A (address) and S (scalar) registers. Access time is 17 CPs + vector length for a V (vector) register and 16 CPs + block length for a block transfer to a B (intermediate address) or T (intermediate scalar) register.

The maximum transfer rate per CPU for B, T, and V registers is three words per CP; for A and S registers per CPU, it is one word every 2 CPs. Transfer of instructions to instruction buffers occurs at a rate of 32 parcels (8 words) per CP. For the I/O section, the transfer rate is 2 words per CP.

Central Memory features are summarized below and are described in detail in the following paragraphs.

- Shared access from both CPUs
- 2 million or 4 million words of integrated circuit memory
- 64 data bits and 8 error correction bits per word
- 16 or 32 interleaved banks
- 4-CP bank cycle time
- Single error correction/double error detection (SECDED)
- 3 words per CP transfer rate to B, T, and V registers per CPU

- 1 word per 2 CP transfer rate to A and S registers per CPU
- 8 words per CP transfer rate to instruction buffers
- 2 words per CP transfer rate to I/O concurrent with all memory activity except instruction fetch and exchange

MEMORY ORGANIZATION

Memory is organized to provide fast, efficient access for all CPUs. Data transfers to and from memory are corrected with single error correction, double error detection (SECDED). Central Memory is organized into four sections with 4 or 8 banks in each section. The 16-bank phasing is standard for a 2-million word system (model 22), and 32-bank phasing is standard for a 4-million word system (model 24).

As shown in figure 2-1, each CPU is connected to an independent access path into each of the four sections. This configuration allows up to eight memory references per clock period.

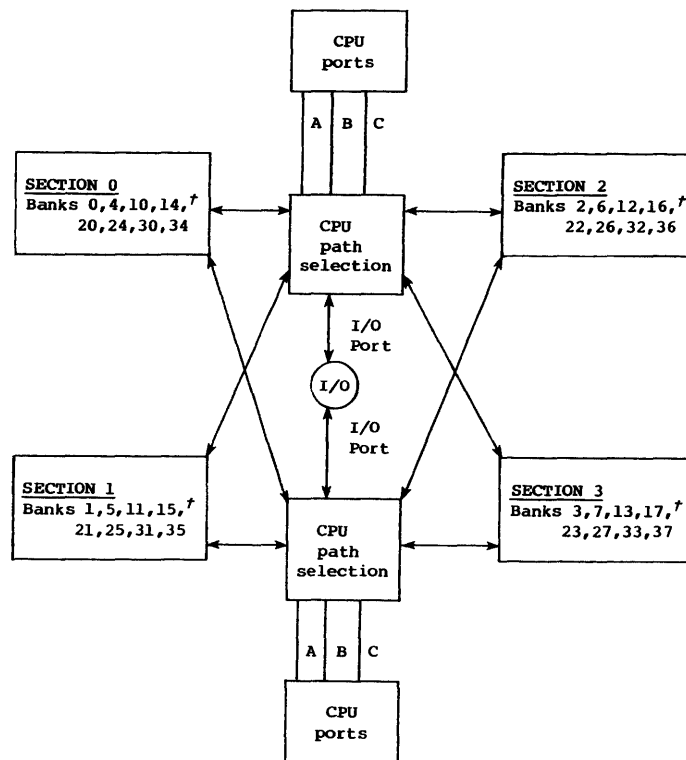

Figure 2-1. Central Memory organization for a dual-processor system

† Low-numbered 4 banks in each section are in a 16-bank system.

MEMORY ADDRESSING

Memory addressing is dependent on system memory architecture (chip size and number of banks) and memory size. Memory addressing for 6-column and 12-column dual-processor systems is described in the following paragraphs.

Memory addressing for 6-column mainframe

A word in a 32-bank memory is addressed in a maximum of 22 bits as shown in figure 2-2. The low-order 5 bits specify one of the 32 banks. The next 14-bit field specifies an address within the chip. The high-order 3 bits specify one chip on the module.

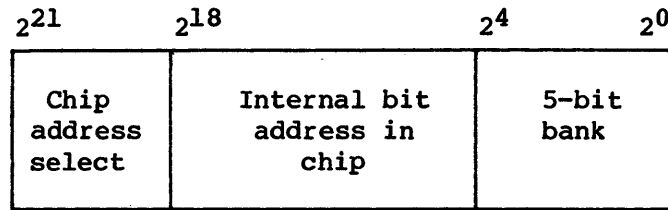

Figure 2-2. 6-column memory address (32 banks)

A word in a 16-bank memory is addressed in a maximum of 21 bits as shown in figure 2-3. In this case, the low-order 4 bits specify one of the 16 banks. The next 14-bit field specifies an address within the chip. The high-order 3 bits specify one chip on the module.[†]

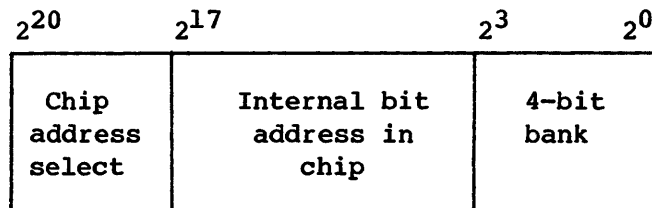

Figure 2-3. 6-column memory address (16 banks)

[†] Hardware assembles the address using a 4-bit bank field. The software, when assembling the address for memory error correction, will receive 5 significant bits from the Exchange Package. The high-order bit (bit 4 counting right to left from 0) must be discarded by the software when assembling the address for memory error correction.

Memory addressing for 12-column mainframe

A word in a 32-bank memory is addressed in a maximum of 22 bits as shown in figure 2-4. The low-order 5 bits specify one of the 32 banks. The next 12-bit field specifies an address within the chip. The high-order 5 bits specify one chip on the module.

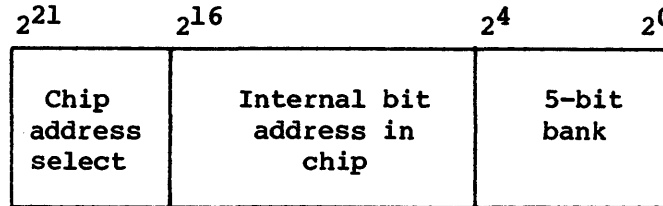

Figure 2-4. 12-column memory address (32 banks)

A word in a 16-bank memory is addressed in a maximum of 21 bits as shown in figure 2-5. In this case, the low-order 4 bits specify one of the 16 banks. The next 12-bit field specifies an address within the chip. The high-order 5 bits specify one chip on the module.[†]

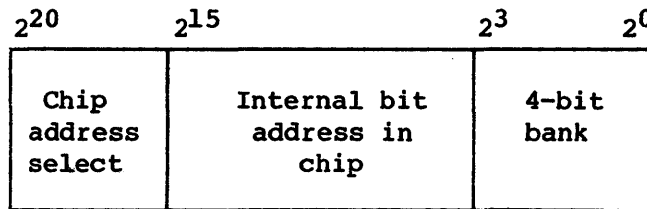

Figure 2-5. 12-column memory address (16 banks)

MEMORY ACCESS

Both CPUs have four memory access ports, referred to as Port A, Port B, Port C, and I/O. Each port is capable of making one reference per CP. Ports A, B, and C are used for CPU register transfers.

[†] Hardware assembles the address using a 4-bit bank field. The software, when assembling the address for memory error correction, will receive 5 significant bits from the Exchange Package. The high-order bit (bit 4 counting right to left from 0) must be discarded by the software when assembling the address for memory error correction.

B, T, and vector memory instructions issue to a particular memory port:

- Vector read (block reads only), B read instructions (176, 034) use Port A.
- Vector read (block reads only), T read instructions (176, 036) use Port B.
- Vector store, B, or T store instructions (177, 035, and 037) and scalar instructions (100-137) use Port C.

Once an instruction issues to a port, that port is reserved until all references are made for that instruction.

The references for each element of a block transfer (V,B,T) are made and completed in sequence through a port. However, since each reference is examined individually for possible conflicts, the data flow for a transfer may not be continuous. If an instruction requires a port that is busy, issue is blocked. Total execution time of the transfer depends on the number and type of conflicts encountered during the transfer.

CAUTION

Because concurrent block reads and writes are not examined for read before write or write before read (memory overlap hazard conditions), the software must detect where this condition occurs and ensure sequential operation.

The bidirectional memory mode enable (0025), bidirectional memory mode disable (0026), and the complete memory reference (0027) instructions are provided to resolve these cases and assure sequential operation. If the bidirectional memory mode is clear, block reads and writes are not allowed to operate concurrently within that CPU. Instruction 0027 allows the program to wait until the last references of all preceding block transfers are past the conflict resolution stage within the CPU issuing it and the transferred data is being transmitted to the designated memory or register locations. Instruction 0027 provides software a mechanism, wherever necessary in the program, to guarantee sequential memory operation within a CPU or between CPUs.

Issue of scalar memory references requires Ports A, B, and C to be available, ensuring sequential operation between block transfers and scalar references within a CPU.

A scalar reference conflict is detected in CP 3 of execution. If a conflict occurs, one more scalar reference is allowed to issue. A third scalar reference holds issue if the conflict condition still exists for the preceding scalar reference.

Scalar references always execute in the order they are issued within a CPU. Instruction 0027 detects when all scalar references are past the conflict resolution stage within the CPU issuing it.

One-half of the CPU I/O channels reference memory through each CPU's I/O port. The I/O port can be active regardless of the activities on Ports A, B, or C.

When an instruction fetch request occurs, all referencing from the eight memory ports is inhibited. When memory is quiet (0 to 3 CPs), the fetch proceeds and references 32 banks in the next 4 CPs (6 CPs if 16 banks). Then the referencing of the eight ports is enabled.

NOTE

A fetch sequence that follows a scalar store can, under certain conditions, complete before the store. For this to happen, however, an out-of-buffer condition must arise before the scalar store is in CP 2 of execution. The out-of-buffer condition can occur before the scalar store is in CP 2 of execution if a buffer boundary is crossed without doing a branch. This presents a problem only if the fetch and store are to the same area in memory. Therefore, software that utilizes dynamic coding should ensure that the code generated is actually in memory before that area of memory is fetched into the instruction buffers.

An exchange requires all activities within a CPU to complete before the exchange request is made.

When the exchange request is made, all referencing from the four memory ports of the other CPU is inhibited. When memory is quiet (0 to 3 CPs), the exchange proceeds and references 16 banks in the next 21 CPs. Each bank is referenced twice during this time, once for a read and once for a write. A fetch request follows immediately after the exchange reference is complete and then referencing from the four memory ports of the other CPU is enabled.

Conflict resolution

During each clock period, references to the memory ports in the system are examined for memory access conflicts. If a conflict occurs for a reference, the reference is held and no further referencing from that port is allowed until the conflict is resolved.

Three types of memory access conflicts can occur: Bank Busy, Simultaneous Bank, and Section Access.

Bank Busy conflict - The Bank Busy conflict is caused by any port within or between CPUs requesting a bank currently in a reference cycle. Resolution of this conflict occurs when the bank cycle is complete. All ports in the CPU are held 1, 2, or 3 CPs because of a Bank Busy conflict.

Simultaneous Bank conflict - The Simultaneous Bank conflict is caused by two or more ports in different CPUs requesting the same bank. Resolution of this conflict is based on a priority (see subsection below on Memory access priorities). All ports in a CPU are held 1 CP because of a Simultaneous Bank conflict. A Bank Busy conflict always follows a Simultaneous Bank conflict.

Section Access conflict - The Section Access conflict is caused by two or more ports in the same CPU requesting any bank in the same section. Resolution of this conflict is based on priority. The highest priority port is allowed to proceed, all other ports involved in this conflict hold (see subsection below on Memory access priorities). The port is held 1 CP because of a Section Access conflict.

Memory access priorities

The following priorities are used to resolve memory access conflicts.

- Intra-CPU priority: the priority between Ports A, B, and C is determined by the following conditions:
 - Any port with an odd increment always has a higher priority than a port with an even increment, regardless of their issued sequence.
 - Among all ports with the same type of increment (odd or even), the relative time of issue determines the priority, with the first issued having the highest priority.
- Inter-CPU priority: every 4 CPs the priority between CPUs changes.
- I/O priority: the I/O ports are always lowest priority, within CPUs.

16-BANK PHASING

The effect of 16-bank phasing on instruction fetches is a predictable increase of 2 CPs for filling instruction buffers. Otherwise, the amount of performance degradation for 16 banks instead of 32 banks is not readily predictable since it largely results from an increased number of memory conflicts.

For maintenance purposes, a 32-bank system can be modified to operate with only 16 banks and use either the lower or upper half of memory. Maintenance is accomplished by setting the bank select switch to the lower or upper banks.

MEMORY ERROR CORRECTION

A single error correction/double error detection (SECDED) network is used between a CPU and memory. SECDED assures that data written into memory can be returned to the CPU with consistent precision (figure 2-6).

If a single bit of a data word is altered, the single error alteration is automatically corrected before passing the data word to the computer. If 2 bits of the same data word are altered, the error is detected but not corrected. In either case, the CPU can be interrupted, depending on interrupt options selected to allow processing of the error. For 3 or more bits in error, results are ambiguous.

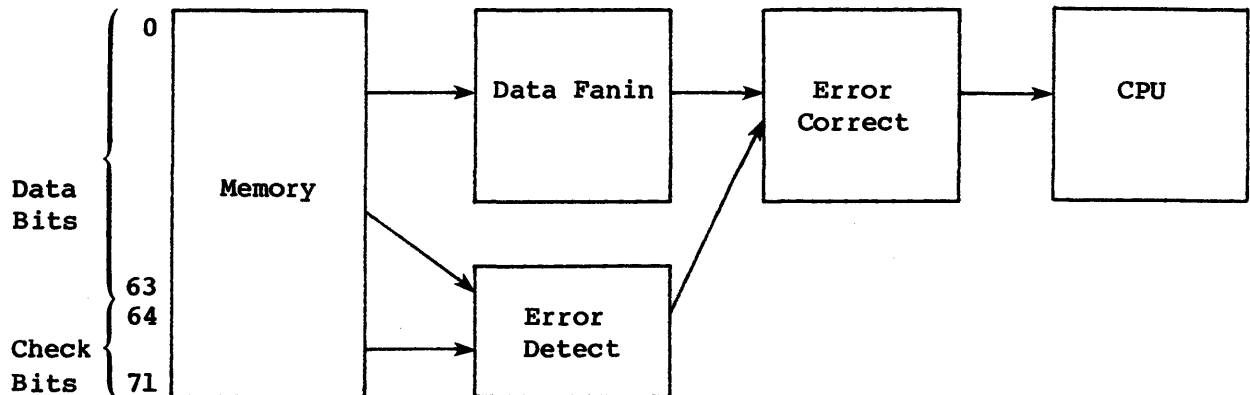

Figure 2-6. Memory data path with SECDED

The SECDED error processing scheme is based on error detection and correction codes devised by R. W. Hamming.[†] An 8-bit check byte is

[†] Hamming, R.W., "Error Detection and Correcting Codes," Bell System Technical Journal, 29, No. 2, pp. 147-160 (April, 1950).

appended to the 64-bit data word before the data is written in memory. The 8 check bits are generated as even parity bits for a specific group of data bits. Figure 2-7 shows the bits of the data word used to determine the state of each check bit. An X in the horizontal row indicates that data bit contributes to the generation of that check bit. Thus, check bit 0 is the bit that makes group parity even for the group of bits $2^1, 2^3, 2^5, 2^7, 2^9, 2^{11}, 2^{13}, 2^{15}, 2^{17}, 2^{19}, 2^{21}, 2^{23}, 2^{25}, 2^{27}, 2^{29}$, and 2^{31} through 2^{55} .

The 8 check bits and the data word are stored in memory at the same location. When read from memory, the same 64-bit matrix of figure 2-7 is used to generate a new set of check bits, which are compared with the old check bits. The resulting 8 comparison bits are called syndrome[†] bits (S bits). The states of these S bits are all symptoms of any error that occurred (1=No compare). If all syndrome bits are 0, no memory error is assumed.

CHECK BYTE																							
271	270	269	268	267	266	265	264	263	262	261	260	259	258	257	256	255	254	253	252	251	250	249	248
check bit 0							x									x	x	x	x	x	x	x	x
check bit 1						x		x	x	x	x	x	x	x	x								
check bit 2					x			x	x	x	x	x	x	x	x	x	x	x	x	x	x	x	x
check bit 3				x				x	x	x	x	x	x	x	x	x	x	x	x	x	x	x	x
check bit 4			x					x	x							x	x						
check bit 5		x						x	x			x	x			x	x				x	x	
check bit 6	x							x	x	x	x					x	x	x	x				
check bit 7	x							x			x		x	x		x			x		x	x	

x	x	x	x	x	x	x	x	x	x	x	x	x	x	x	x	x				x			x
x	x	x	x	x	x	x	x	x	x	x	x	x	x	x	x	x	x				x	x	
								x	x	x	x	x	x	x	x	x	x	x	x				
x	x	x	x	x	x	x	x	x								x				x			x
x	x							x								x							
x	x							x	x							x	x	x	x	x	x	x	x
x	x	x	x					x	x	x	x					x	x	x	x	x	x	x	x
x								x								x	x	x	x	x	x	x	x

x								x								x							
x	x							x	x							x	x						
x	x	x	x					x	x	x	x					x	x	x	x				
x								x								x							
x	x	x	x	x	x	x	x	x	x	x	x	x	x	x	x	x	x	x	x	x	x	x	x
x	x	x	x	x	x	x	x	x	x	x	x	x	x	x	x	x	x	x	x	x	x	x	x

Figure 2-7. Error correction matrix

[†] Syndrome: any set of characteristics regarded as identifying a certain type, condition, etc. Websters New World Dictionary.

Any change of state of a single bit in memory causes an odd number of syndrome bits to be set to 1. A double error (an error in 2 bits) appears as an even number of syndrome bits set to 1.

The matrix is designed so that:

- If all syndrome bits are 0, no error is assumed.
- If only 1 syndrome bit is 1, the associated check bit is in error.
- If more than 1 syndrome bit is 1 and the parity of syndrome bits S0 through S7 is even, then a double error (or an even number of bit errors) occurred within the data bits or check bits.
- If more than 1 syndrome bit is 1 and the parity of all syndrome bits is odd, then a single and correctable error is assumed to have occurred. The syndrome bits can be decoded to identify the bit in error.
- If 3 or more memory bits are in error, the parity of all syndrome bits is odd and results are ambiguous.

Modules involved with generating and interpreting the 8-bit check byte used for SECDED include logic that can be used for verifying check bit storage, check bit generation, and error detection and correction. Refer to Appendix D for information on SECDED maintenance functions.

INTER-CPU COMMUNICATION SECTION

The inter-CPU communication section of the mainframe contains special hardware for communication between the two CPUs, for control, and for a real-time clock. The Real-time Clock (RTC), Shared Address (SB), Shared Scalar (ST), and Semaphore (SM) registers are shared by the CPUs. These registers, with their sources and destinations, are shown in figure 2-8 and described in the following paragraphs.

REAL-TIME CLOCK

The mainframe contains one Real-time Clock (RTC) register which is shared by both CPUs. Programs can be timed precisely by using the clock period (CP) counter. This counter is 64 bits wide and advances one count each 9.5 nanosecond clock period. Since the clock advances synchronously with program execution, it can be used to time the program to an exact number of CPs. However, in such an application, the counting can contain counts from other tasks if an interrupt occurs before the end time is read.

Instructions used with the RTC register are:

0014j0	RT	Sj	Enter the RTC register with (Sj)
072i00	Si	RT	Transmit (RTC) to Si

A program reads the CP counter using instruction 072 and resets it with instruction 0014j0. Loading or reading the CP counter can occur from all CPUs at the same time. If more than one CPU is in monitor mode, the software should ensure that only one CPU enters a value into this register.

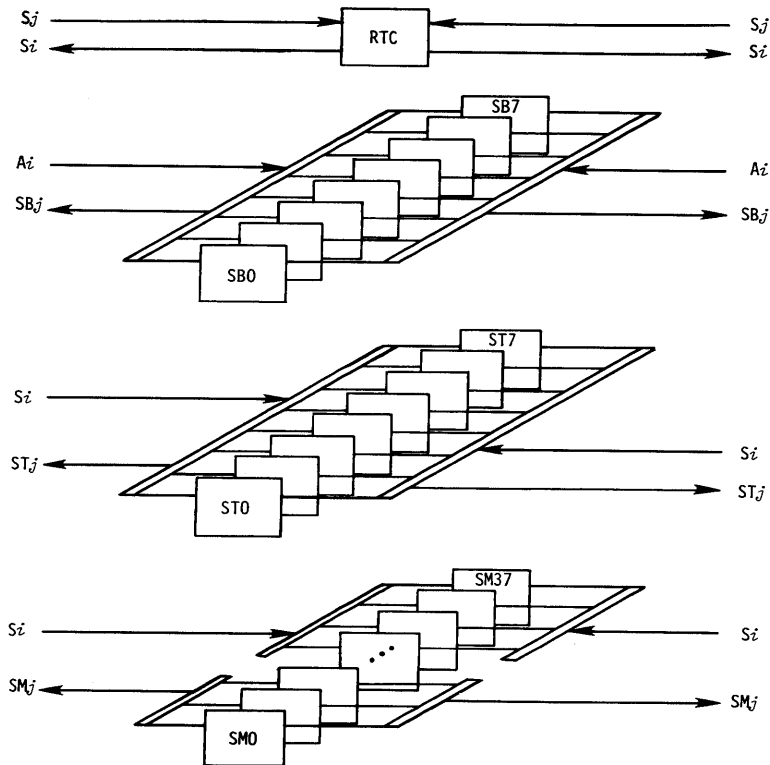

Figure 2-8. Shared registers and real-time clock

INTER-CPU COMMUNICATION AND CONTROL

Three identical sets of shared registers are used for communication and control between CPUs. Each set contains eight 24-bit Shared Address (SB) registers, eight 64-bit Shared Scalar (ST) registers and 32 1-bit Semaphore (SM) registers.

Each CPU's Cluster Number (CLN) register determines which set of shared registers is accessed by a CPU (clustering). The CLN register is loaded

from the Exchange Package or if the CPU is in monitor mode, through instruction 0014j3.

The CLN register can contain one of four different values. Values 1, 2, or 3 allow the CPU to access one of the three sets of shared registers. Value 0 prevents any access to shared registers by the CPU. If the value is 0, instructions regarding the shared registers become no-ops, except for the instructions returning values to A_i or S_i , which return a 0 value. If the CLN registers in both CPUs are set to the same value (1, 2, or 3), then the two CPUs share a common set of SB, ST, and SM registers.

Shared Address and Shared Scalar registers

The Shared Address (SB) and Shared Scalar (ST) registers are used for passing address and scalar information from one CPU to another. No hardware reservations are made on these registers. Any necessary reservations to restrict access to these registers must be handled in the software through use of the Semaphore (SM) registers or by shared memory design. The single hardware restriction on access to the SB and ST registers is that only one read or one write operation can occur in a CP.

The instructions used with the SB and ST registers are:

026i.j7	A_i SBj	Transmit (SBj) to A_i
027i.j7	SBj A_i	Transmit (A_i) to SBj
072i.j3	S_i STj	Transmit (STj) to S_i
073i.j3	STj S_i	Transmit (S_i) to STj

Access conflicts to Shared Address (SB) and Shared Scalar (ST) registers occur under the conditions shown in table 2-1 regardless of clustering. For example, if a read instruction for CPU 0 and a read instruction for CPU 1 enter CIP simultaneously, a conflict occurs and CPU 1 holds issue for one CP.

Semaphore registers

The Semaphore (SM) registers are used for control between the CPUs. No hardware reservations are made on these registers. Loading or reading the SM registers or setting or clearing a particular SM register can occur at any time from either or both CPUs.

The test and set instruction (0034jk) is the only operation on the SM registers including a hardware interlock. This interlock prevents a simultaneous test and set operation on the same SM register from both CPUs. The test and set instruction first tests the value of the selected SM register. If the value is 0, the instruction issues and sets that SM register to a 1. If the value is 1, the instruction holds issue until the value is 0.

When all CPUs in a cluster are holding issue on a test and set instruction, a deadlock interrupt can occur. If the CLN registers in both CPUs are equal and not 0, both CPUs belong to the same cluster and both CPUs must be holding issue on a test and set instruction to cause a deadlock interrupt. When that happens, both CPUs in the cluster receive deadlock interrupts. If the CLN registers in both CPUs are not equal, the two CPUs are in different clusters. If one CPU holds issue on a test and set instruction, that CPU receives a deadlock interrupt. No deadlock interrupt can occur in cluster 0 (CLN=0).

Table 2-1. Access conflicts to shared registers in a dual-processor computer

SB or ST register operation		Hold issue 1 CP
CPU 0	CPU 1	
READ (first CP in CIP)	READ (first CP in CIP)	CPU 1
READ (not first CP in CIP)	READ (first CP in CIP)	CPU 1
READ (first CP in CIP)	READ (not first CP in CIP)	CPU 0
READ (not first CP in CIP)	READ (not first CP in CIP)	CPU 0
WRITE (first CP in CIP)	WRITE (first CP in CIP)	CPU 1
WRITE (not first CP in CIP)	WRITE (first CP in CIP)	CPU 1
WRITE (first CP in CIP)	WRITE (not first CP in CIP)	CPU 0
WRITE (not first CP in CIP)	WRITE (not first CP in CIP)	CPU 0
READ (Write issued 3 CPs before)		CPU 0
READ	(Write issued 3 CPs before)	CPU 0
	READ (Write issued 3 CPs before)	CPU 1
(Write issued 3 CPs before)	READ	CPU 1

When an interrupt occurs, normally the instructions already in the NIP and CIP registers are allowed to issue before the exchange sequence starts. If a test and set instruction is holding in the CIP register and an interrupt occurs, a special exchange start-up sequence is initiated. In this case the instruction in the NIP register and the test and set instruction in the CIP register are discarded and the Program Counter (P) register is adjusted to point to the discarded test and set instruction. The Waiting on Semaphore (WS) flag in the Exchange Package sets, indicating a test and set instruction was holding in the CIP register when the interrupt occurred. The exchange sequence is then started.

Instructions used with the SM registers are:

0034jk	SMjk	1,TS	Test and set, SMjk
0036jk	SMjk	0	Clear SMjk
0037jk	SMjk	1	Set SMjk
072i02	Si	SM	Transmit (SM) to Si
073i02	SM	Si	Transmit (Si) to SM

CPU INPUT/OUTPUT SECTION

The Input/Output section of the mainframe is shared by both Central Processing Units (CPUs). The mainframe supports three channel types identified by their maximum transfer rates of 1250 Mbytes per second, 100 Mbytes per second, and 6 Mbytes per second.

One 1250 Mbyte per second channel pair is used to transfer data between the Central Memory and the Solid-state Storage Device (SSD). These channels are 128 bits wide and use 16 check bits in each direction. A maximum transfer rate of over 10 gigabits per second is possible on a 1250 Mbyte per second channel. The channel is two parallel 64-bit channels each with SECDED; therefore, under certain circumstances the full-width channel can correct double errors.

Two 100 Mbyte per second channel pairs transfer data between Central Memory and an I/O Subsystem. A 100 Mbyte per second channel is 64 bits wide and uses 8 check bits in each direction. Data words are transferred in blocks of 16 under control of Data Ready and Data Transmit control signals. Each 100 Mbyte per second channel has a maximum transfer rate of approximately 850 Mbits per second.

I/O Subsystem communication with the CPUs is over four pairs of control channels, each with a maximum transfer rate of 6 Mbytes per second. Each 6 Mbyte per second channel is 16 bits wide.

There is one I/O port from each CPU. The channels are hardwired into a port with two 6 Mbyte per second channel pairs, one 100 Mbyte per second channel pair, and one-half of the 1250 Mbyte per second channel per

port. Each port can transfer data at a rate of one word per CP. For the 100 Mbyte per second channel and 1250 Mbyte per second channel, each time a buffer makes a reference, it holds the port until complete, usually 16 words.

All I/O (including 100 Mbyte and 1250 Mbyte per second channels) uses the I/O ports to memory. Access to these ports is controlled by a scanner. All CPU memory ports (Ports A, B, and C) have higher priority than the I/O ports.

Channel features of the input/output section are summarized below and described in the remainder of this section.

- One channel pair with 1250 Mbytes per second maximum transfer rate per channel
 - 128 data bits and 16 check bits in each direction
- Two channel pairs with 100 Mbytes per second maximum transfer rate per channel
 - 64 data bits, 3 control bits, and 8 check bits in each direction
- Four I/O channel pairs, 6 Mbytes per second maximum transfer rate per channel
 - Shared control from the CPUs
 - 16 data bits, 3 control bits, and 4 parity bits in each direction
 - Lost data detection
- Channels are divided into four groups, each group contains either input or output channels
- Channel groups are served equally by memory (each group is scanned every 4 CPs)
- Channel priority resolved within channel groups

DATA TRANSFER FOR SOLID-STATE STORAGE DEVICE

Data is transferred directly between the Solid-state Storage Device (SSD) and the mainframe using 1250 Mbyte per second channels. A 1250 Mbyte per second channel is 128 bits wide and is programmed through software. Port 3 of the SSD connects with the CRAY X-MP system. Programming details for the SSD are described in the Solid-state Storage Device (SSD) Reference Manual, CRI publication HR-0031.

DATA TRANSFER FOR I/O SUBSYSTEM

A 100 Mbyte per second channel pair transfers data between Central Memory of the mainframe and the Buffer I/O Processor (BIOP) of the I/O Subsystem. A second 100 Mbyte per second channel pair can transfer data between Central Memory and a Disk I/O Processor (DIOP) or Auxiliary I/O Processor (XIOP).[†] Each channel is 64 bits wide and handles data at approximately 100 Mbytes per second. Each channel uses an additional 8 check bits for single error correction/double error detection (SECDED), as is used in Central Memory.

The CPU side of a 100 Mbyte per second channel pair uses a pair of 16-word buffers to stream the data out of Central Memory and another pair to stream data into Central Memory. On output, as one buffer block is being sent to the I/O Processor (IOP), the other buffer is filling from Central Memory. Similarly, on input, one buffer block is filling from an IOP while the other is transmitting to Central Memory.

At the IOP side of a 100 Mbyte per second channel pair, data passing into Local Memory (an I/O Processor's memory) is double-buffered and disassembled into 16-bit parcels. The channel side passing data from Local Memory simply assembles 16-bit parcels into 64-bit words for transmission to a CPU.

An I/O Processor controls a 100 Mbyte per second channel pair linking it with Central Memory. The IOP initiates all data transfers on the channel and performs all error processing required for the channel. There are no CPU instructions for the 100 Mbyte per second channel pair. Programming details for the 100 Mbyte per second channel pair are contained in the I/O Subsystem Reference Manual, CRI publication HR-0030.

6 MBYTE PER SECOND CHANNELS

Standard control channels for the system are 6 Mbyte per second channels. Each 6 Mbyte per second channel has 16-bit asynchronous control logic used for front-end interfaces. The instructions used with 6 Mbyte per second channels follow.

0010jk	CA,Aj Ak	Set the Current Address (CA) register for the channel indicated by (Aj) to (Ak) and activate the channel
0011jk	CL,Aj Ak	Set the Limit Address (CL) register for the channel indicated by (Aj) to (Ak)

[†] Software does not currently support data transfer using the 100 Mbyte per second channel pair to an XIOP.

0012jk	CI, Aj	Clear the Interrupt flag and Error flag for the channel indicated by (Aj): Output channel k=0; clear MC, k=1; set MC. Input channel k=0; no operation, k=1; clear held ready.
033i00	Ai CI	Transmit channel number to Ai
033i,j0	Ai CA, Aj	Transmit address of channel (Aj) to Ai
033i,j1	Ai CE, Aj	Transmit Error flag of channel (Aj) to Ai

MULTI-CPU PROGRAMMING

The 6 Mbyte per second I/O channels can operate from either CPU, and either CPU can issue instructions to any of the channels. No hardware interlock exists between the CPUs; therefore, software must ensure that only one CPU is servicing I/O at a time, while in monitor mode. Instruction 033 is independent in nature and can be issued without an interlock.

The following conditions must be met for an I/O interrupt to occur.

- Neither CPU is waiting for an exchange.
- Neither CPU is in monitor mode.
- An interrupt is present.

Normally, the interrupt from a 6 Mbyte per second channel is directed toward the CPU that last issued a clear interrupt instruction (0012) to that channel. However, because an I/O interrupt occurs in only one CPU at a time, the following conditions (in priority order) determine the CPU toward which the interrupt is directed. Once in monitor mode, a CPU should service all I/O interrupts.

1. All I/O interrupts are directed toward a CPU that has the Select External Interrupt Mode set.
2. If neither CPU has selected external interrupts, then interrupts are directed toward a CPU holding issue on a test and set instruction.
3. If neither conditions 1 nor 2 exist or if they exist in both CPUs, the interrupt is directed to the CPU that last issued a clear interrupt instruction to that channel.

6 MBYTE PER SECOND CHANNEL OPERATION

Each input or each output channel directly accesses Central Memory. Input channels store external data in memory and output channels read data from memory. A primary task of a channel is to convert 64-bit Central Memory words into 16-bit parcels or 16-bit parcels into 64-bit Central Memory words. Four parcels make up one Central Memory word with bits of the parcels assigned to memory bit positions as shown in table 2-2. In both input and output operations, parcel 0 is always transferred first.

Each input or output channel has a data channel (4 parity bits, 16 data bits, and 3 control lines), a 64-bit assembly or disassembly register, a channel Current Address (CA) register, and a channel Limit Address (CL) register.

Three control signals (Ready, Resume, and Disconnect) coordinate the transfer of parcels over the channels. In addition to the three control signals, the output channel of a pair has a Master Clear line. Appendix B describes the signal sequence of a 6 Mbyte per second channel.

Table 2-2. Channel word assembly/disassembly

Characteristic	Bit position	Number of bits	Comment
Channel data bits	2 ¹⁵ -2 ⁰	16	Four 4-bit groups
Channel parity bits		4	One per 4-bit group
CRAY X-MP word	2 ⁶³ -2 ⁰	64	
Parcel 0	2 ⁶³ -2 ⁴⁸	16	First in or out
Parcel 1	2 ⁴⁷ -2 ³²	16	Second in or out
Parcel 2	2 ³¹ -2 ¹⁶	16	Third in or out
Parcel 3	2 ¹⁵ -2 ⁰	16	Fourth in or out

I/O interrupts can be caused by the following:

- On all output channels, if (CA) becomes equal to (CL), then the resume for the last parcel transmitted sets interrupt.
- External device disconnect is received on any input channel and channel is active.
- Channel error condition occurs (described later in this section).

The number of the channel causing an interrupt can be determined by using instruction 033, which reads into A_i the highest priority channel number requesting an interrupt. The lowest numbered channel has the highest priority. The interrupt request continues until cleared by the monitor program when an interrupt from the next highest priority channel, if present, is sensed. All interrupts are available through instruction 033 to either CPU. Channel numbers for 6 Mbyte per second channels are 10_8 through 17_8 (10/11, 12/13, 14/15, and 16/17 - even for input, odd for output).

INPUT CHANNEL PROGRAMMING

To start an input operation, the CPU program (see figure 2-9):

1. Sets the channel limit address to the last word address + 1 (LWA+1).
2. Sets the channel current address to the first word address (FWA).

Setting the current address causes the Channel Active flag to set. The channel is then ready to receive data. When a 4-parcel word is assembled, the word is stored in memory at the address contained in the CA register. When the word is accepted by memory, the current address is advanced by 1.

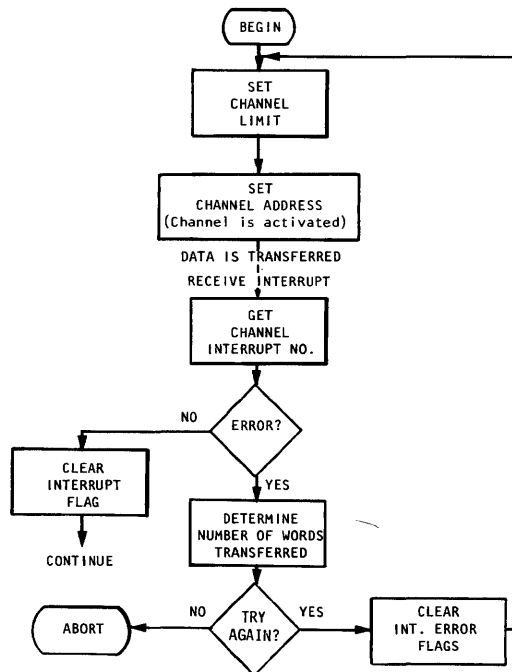

Figure 2-9. Basic I/O program flowchart

An external transmitting device sends a Disconnect signal to indicate end of a transfer. When the Disconnect signal is received, the Channel Interrupt flag sets and a test is performed to check for a partially assembled word. If the partial word is found, the valid portion of the word is stored in memory and the unreceived, low-order parcels are stored as zeros.

The Interrupt flag sets when a Disconnect signal is received or when the channel Error flag is set.

INPUT CHANNEL ERROR CONDITIONS

Input channel error conditions can occur at a parcel level (parity error) or channel level (unexpected Ready signal). When a parcel in error occurs, the Parity Fault flag sets immediately. The Parity Fault flag does not generate an interrupt, it is saved and sets the Error flag when a disconnect occurs. Therefore, the program should check the state of the Error flag when an interrupt is honored. All parcels stored after the error are zeroed.

If a Ready signal is received when the channel is not active (unexpected Ready signal), the Ready condition is held until the channel is activated. At this time a Resume signal is sent. No Error flag is set and no interrupt request is generated. Since the Ready condition is held when the channel is inactive, it is sometimes advantageous to be able to clear this Ready signal before setting up the channel, especially on a deadstart or a resynchronization of the channel after an error. The Ready signal can be cleared by using instruction 0012,j1 to input channel (A_i), clearing any Ready signal being held before issue of instruction 0012,j1.

OUTPUT CHANNEL PROGRAMMING

To start an output operation, the CPU program:

1. Sets the channel limit address to the last word address + 1 (LWA+1).
2. Sets the channel current address to the first word address (FWA).

Setting the current address causes the Channel Active flag to be set. The channel reads the first word from memory addressed by the contents of the CA register. When the word is received from memory, the channel advances the current address by 1 and starts the data transfer.

After each word is read from memory and the current address is advanced, the limit test is made, comparing the contents of the CA register and the CL register. If they are equal, the operation is complete as soon as the last parcel transfer is finished.

The Interrupt flag also sets if an error is detected. The only error that an output channel detects is a Resume signal received when the channel is inactive. No external response is generated.

PROGRAMMED MASTER CLEAR TO EXTERNAL DEVICE

The system can send a Master Clear signal to an external device through the output channel. The external Master Clear sequence is as follows.

1. 0012jk Clears input channel to ensure external activity on the channel pair has stopped
2. 0012jl Clears output channel to ensure CPU activity on the channel pair has stopped. Set Master Clear.
3. Delay 1 Device dependent; determines the duration of the Master Clear signal.
4. 0012j0 Clears the output channel. This turns off the Master Clear signal.
5. Delay 2 Device dependent; allows time for initialization activities in the attached device to complete.

For Cray Research, Inc., front-end interfaces, delays 1 and 2 should each be a minimum of 80 CPs.

MEMORY ACCESS

Each of the four channel groups shown below is assigned a time slot (figure 2-10) that is scanned once every 4 CPs for a memory request. The lowest numbered channel in the group has the highest priority. During the next 3 CPs, the scanner allows requests from the other three channel groups. Therefore, an I/O memory request can occur every CP. The scanner stops for all memory conflicts caused by an I/O reference and also stops for a block (100 Mbyte per second channel) reference while a buffer is referencing, maximum 16 words (figure 2-11).

REFERENCE CONTROL

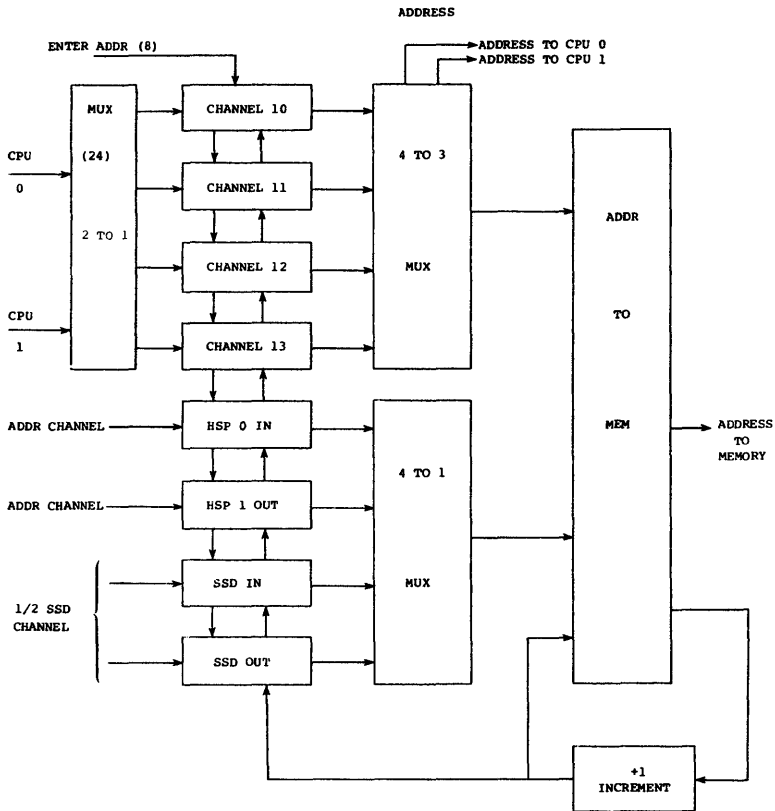
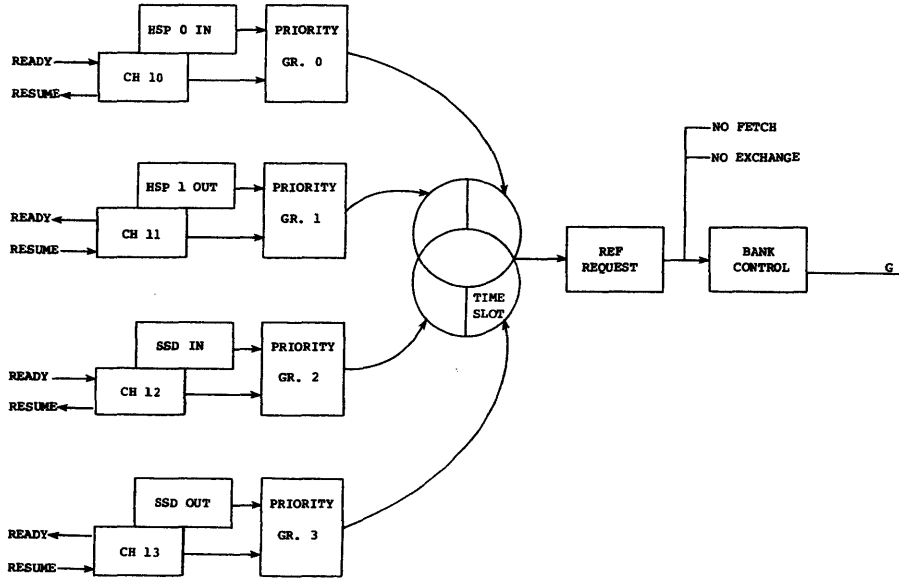

Figure 2-10. Channel I/O control (shown for one processor)

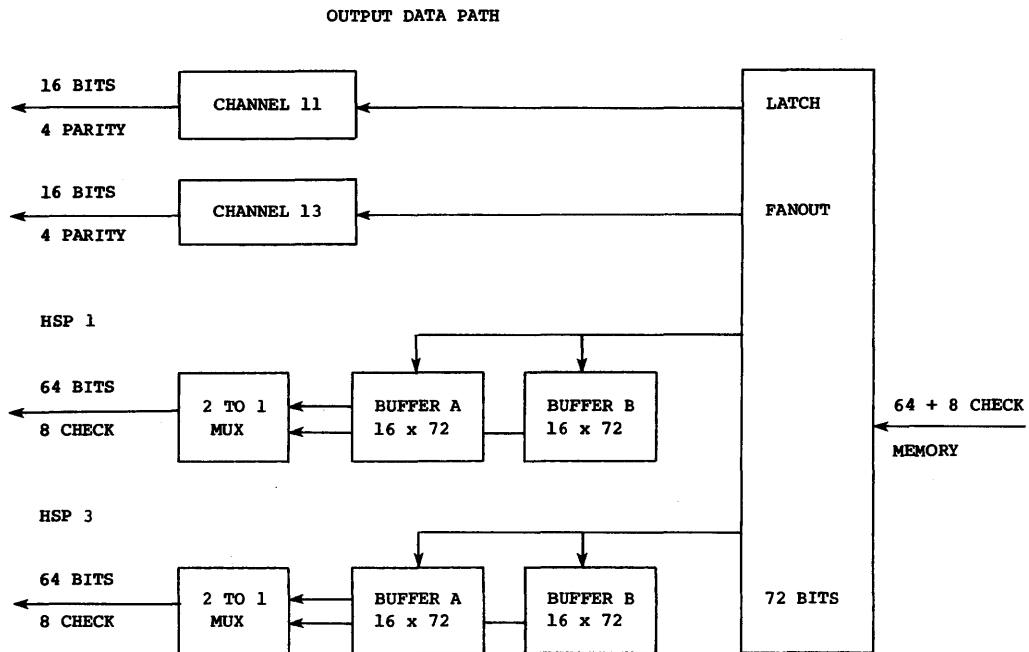
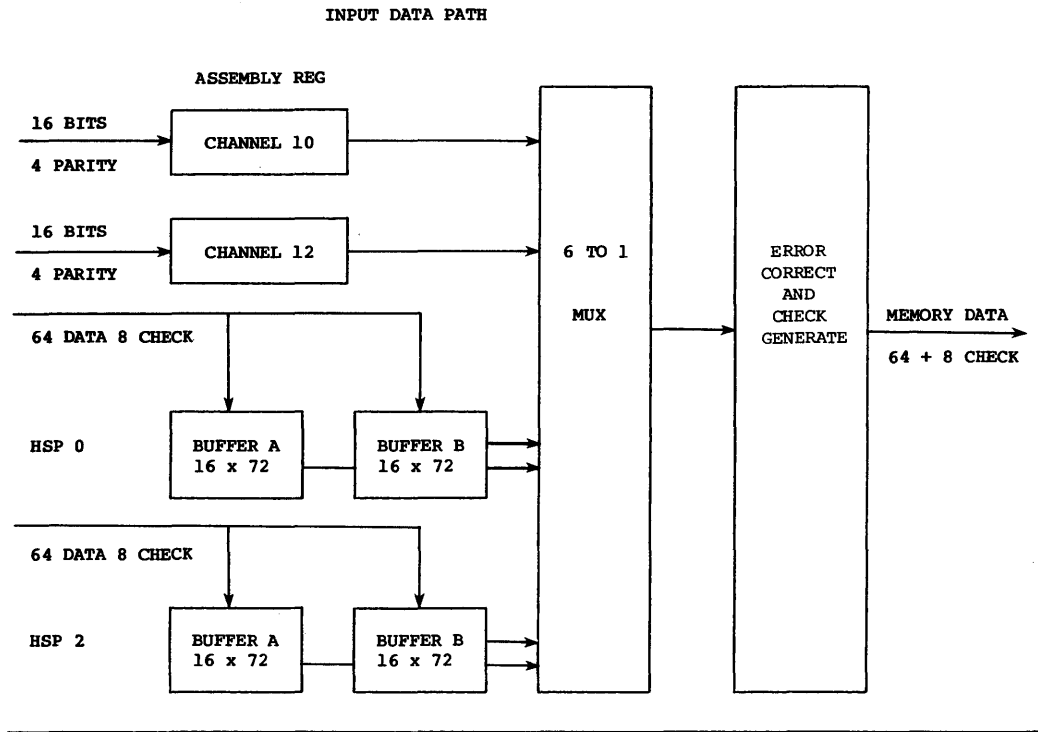

Figure 2-11. Input/output data paths

The 6 Mbyte per second channels are numbered 10g through 17g. The 100 Mbyte per second channels are numbered 0 to 3 in both CPUs (an SSD channel uses channels 2 and 3 of both CPUs). The channels are grouped as follows:

	<u>CPU 0</u>	<u>CPU 1</u>
Group 0 input channels	0,10	0,14
Group 1 output channels	1,11	1,15
Group 2 input channels	2,12	2,16
Group 3 output channels	3,13	3,17

I/O LOCKOUT

An I/O memory request can be locked out by an exchange sequence or instruction fetch sequence.

MEMORY BANK CONFLICTS

Memory bank conflicts are tested for CPU scalar, vector, and I/O memory references. When an exchange sequence or instruction fetch sequence is in progress, all other memory references are locked out.

Each memory bank can accept a new request every 4 CPs. To test for a memory bank conflict, the 5 low-order bits[†] of the memory address are checked against Bank Busy conflicts and other memory references. The bank is busy for 4 CPs on a reference.

I/O MEMORY CONFLICTS

Before testing for a memory bank conflict, a check is made to ensure no exchange sequence or instruction fetch sequence is in progress. If either of these conditions exists, the I/O request is held. The 5 low-order address bits[†] of an I/O reference are tested against Bank Busy conflicts and other memory references. If a bank being referenced is busy, the reference is held and the scanner is stopped.

[†] 4 bits for 16-bank phasing; refer to subsection on Central Memory.

I/O MEMORY REQUEST CONDITIONS

The following conditions must be present for an I/O memory request to be processed:

- I/O request
- Bank not busy
- No simultaneous conflicts with other memory ports
- No fetch request
- No exchange sequence

I/O MEMORY ADDRESSING

All I/O Memory references are absolute. The CA and CL registers are 22 bits, allowing I/O access to all of memory. Setting of the CA and CL registers is limited to monitor mode. I/O Memory reference addresses are not checked for range errors.

INTRODUCTION

Both CPUs have identical, independent control sections containing registers and instruction buffers for instruction issue and control. A control section uses an exchange mechanism for switching instruction execution from program to program. These registers and buffers and the exchange mechanism are described in this section. Memory field protection, programmable clock, and deadstart sequence are also described.

INSTRUCTION ISSUE AND CONTROL

The registers and instruction buffers involved with instruction issue and control are described in the following paragraphs. Figure 3-1 illustrates the general flow of instruction parcels through the registers and buffers.

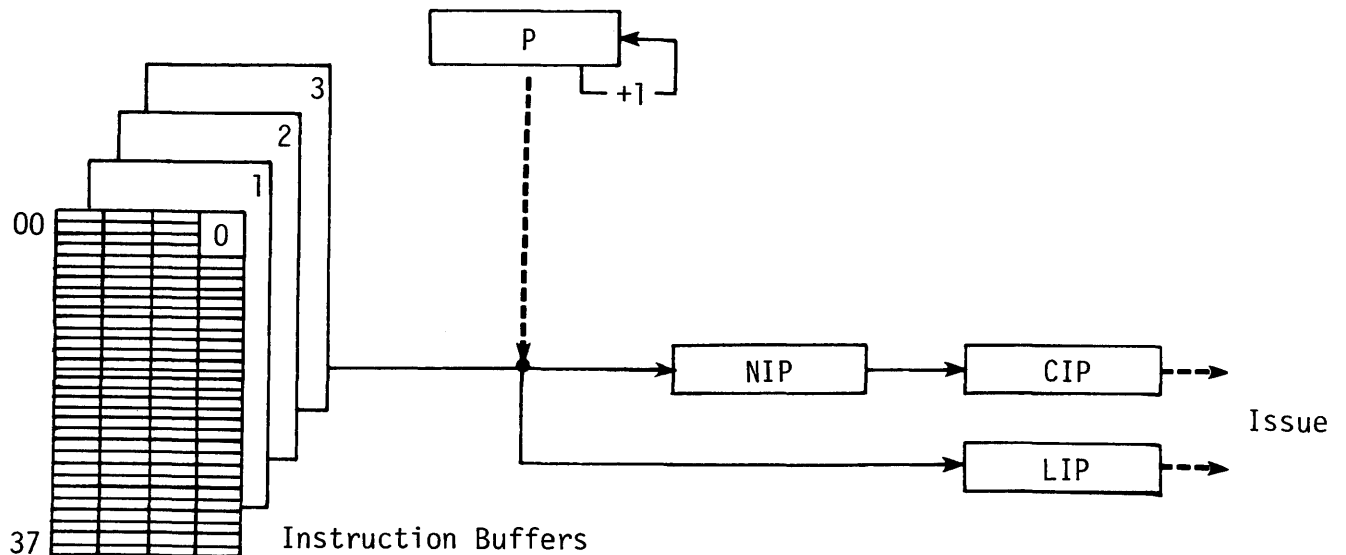

Figure 3-1. Instruction issue and control elements

PROGRAM ADDRESS REGISTER

The 24-bit Program Address (P) register indicates the next parcel of program code to enter the Next Instruction Parcel (NIP) register. The high-order 22 bits of the P register indicate the word address for the program word in memory. The low-order 2 bits indicate the parcel within the word. Except on a branch instruction when the branch is taken or on an exchange, the contents of the P register are advanced 1 when an instruction parcel enters the NIP register.

New data enters the P register on an instruction branch or on an exchange sequence. (The exchange sequence is described under Exchange Mechanism later in this section.) The contents of P are then advanced sequentially until the next branch or exchange sequence. The value in the P register is stored directly into the terminating Exchange Package during an exchange sequence.

The P register is not master cleared. The value stored in P might not be accurate during the deadstart sequence.

NEXT INSTRUCTION PARCEL REGISTER

The 16-bit Next Instruction Parcel (NIP) register holds a parcel of program code before it enters the Current Instruction Parcel (CIP) register.

The NIP register is not master cleared. An undetermined instruction can issue during the master clear interval before the interrupt condition blocks data entry into the NIP register.

CURRENT INSTRUCTION PARCEL REGISTER

The 16-bit Current Instruction Parcel (CIP) register holds the instruction waiting to issue. The term *issue* indicates the transition of an instruction in CIP to its execution phase. If an instruction is a 2-parcel instruction, the CIP register holds the first parcel of the instruction and the Lower Instruction Parcel (LIP) register holds the second parcel. Issue of an instruction in CIP can be delayed until conflicting operations have been completed. Data arrives at the CIP register from the NIP register. Indicators making up the instruction are distributed to all modules having mode selection requirements when the instruction issues.

The control flags associated with the CIP register are master cleared; the register itself is not. An undetermined instruction can issue during the master clear sequence.

LOWER INSTRUCTION PARCEL REGISTER

The 16-bit Lower Instruction Parcel (LIP) register holds the second parcel of a 2-parcel instruction at the time the first parcel of the 2-parcel instruction is in the CIP register.

INSTRUCTION BUFFERS

A CPU has four instruction buffers, each can hold 128 consecutive 16-bit instruction parcels (figure 3-2). Instruction parcels are held in the buffers before being delivered to the NIP or LIP registers.

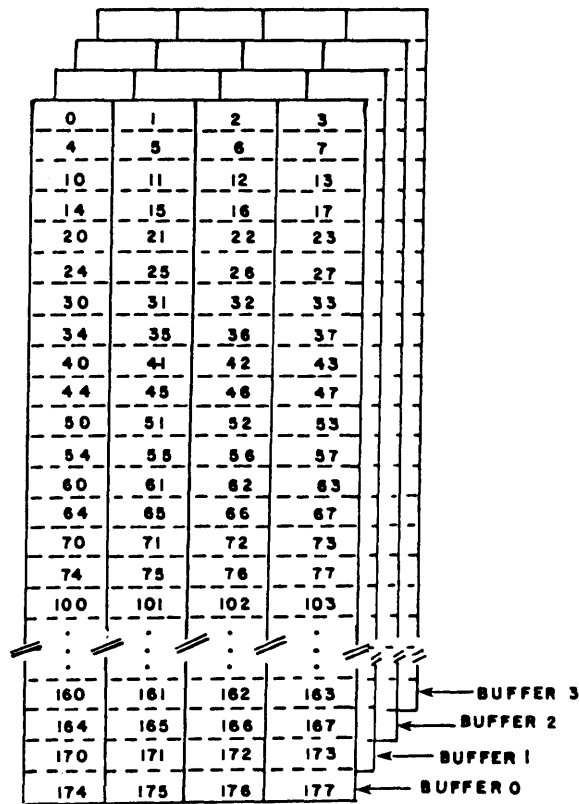

Figure 3-2. Instruction buffers

The beginning instruction parcel in a buffer always has a word address that is a multiple of 40_8 (a parcel address that is a multiple of 200_8) allowing the entire range of addresses for instructions in a buffer to be defined by the high-order 17 bits of the parcel address. Each buffer has a 17-bit beginning address register containing this value.

The Beginning Address registers are scanned each CP. If the high-order 17 bits of the P register match one of the beginning addresses, an

in-buffer condition exists and the proper instruction parcel is selected from that instruction buffer. An instruction parcel to be executed normally is sent to the NIP. However, the second parcel of a 2-parcel instruction is blocked from entering the NIP register and is sent to the LIP register instead. The second parcel of the 2-parcel instruction becomes available when the first parcel issues from the CIP register. At the same time, an all-zero parcel is entered into the NIP register.

On an in-buffer condition, if the instruction is in a different buffer than the previous instruction, a change of buffers occurs requiring a 2-CP delay of the instruction reaching the NIP register.

An out-of-buffer condition exists when the high-order 17 bits of the P register do not match any instruction buffer beginning address. When this condition occurs, instructions must be loaded from memory into one of the instruction buffers before execution can continue. A 2-bit counter determines the instruction buffer receiving the instructions. Each out-of-buffer condition causes the counter to be incremented by 1 so that the buffers are selected in rotation.

Buffers are loaded from memory at the rate of eight words per CP, fully occupying memory. The first group of 32 parcels delivered to the buffer always contains the next instruction required for execution. For this reason, the branch out-of-buffer time is 16 CPs for 32-bank memories and 18 CPs for 16-bank memories, providing memory is not busy (if busy, the branch fetch is delayed until the busy is resolved). Once the fetch proceeds, the remaining groups arrive at a rate of 32 parcels per CP and circularly fill the buffer.

An instruction buffer is loaded with one word of instructions from each of the 32 memory banks or two words from each of the 16 banks. The first four instruction parcels residing in an instruction buffer are always from bank 0. An exchange sequence voids the instruction buffers, preventing a match with the P register and causing the buffers to be loaded as needed.

Forward and backward branching is possible within buffers. Branching does not cause reloading of an instruction buffer if the address of the instruction being branched to is within one of the buffers. Multiple copies of instruction parcels cannot occur in the instruction buffers. Because instructions are held in instruction buffers before issue and after (until the buffer is reloaded), self-modifying code should not be used. Also, because of independent data and instruction memory protection, self-modifying code may be impossible. As long as the address of the unmodified instruction is in an instruction buffer, the modified instruction in memory is not loaded into an instruction buffer.

Although optimizing code segment lengths for instruction buffers is not a prime consideration when programming a CPU, the number and size of the buffers and the capability for forward and backward branching can be used to good advantage. Large loops containing up to 512 consecutive

instruction parcels can be maintained in the four buffers. An alternative is for a main program sequence in one or two of the buffers to make repeated calls to short subroutines maintained in the other buffers. The program and subroutines remain undisturbed in the buffers as long as no out-of-buffer condition or exchange causes reloading of a buffer.

EXCHANGE MECHANISM

A CPU uses an exchange mechanism for switching instruction execution from program to program. This exchange mechanism involves the use of blocks of program parameters known as Exchange Packages and a CPU operation referred to as an exchange sequence. For the convenience of Cray Assembly Language (CAL) programmers, an alternate bit position representation is used when discussing the Exchange Package. The bits are numbered from left to right with bit 0 assigned to the 2^{63} bit position.

EXCHANGE PACKAGE

The Exchange Package (figure 3-3) is a 16-word block of data in memory associated with a particular computer program. The Exchange Package contains the basic parameters necessary to provide continuity from one execution interval for the program to the next.

The Exchange Package contents are arranged in a 16-word block. The exchange sequence swaps data from memory to the operating registers and back to memory. This sequence exchanges data in an active Exchange Package residing in the operating registers with an inactive Exchange Package in memory. The Exchange Address (XA) register address of the active Exchange Package specifies the memory address to be used for the swap. Data is exchanged and a new program execution interval is initiated by the exchange sequence.

The contents of the B, T, V, VM, SB, ST, and SM registers are not swapped in the exchange sequence. Data in these registers must be stored and replaced as required by specific coding in the program supervising the object program execution or by any program that needs this data. (See section 4 for descriptions of the operating registers and the VL register.)

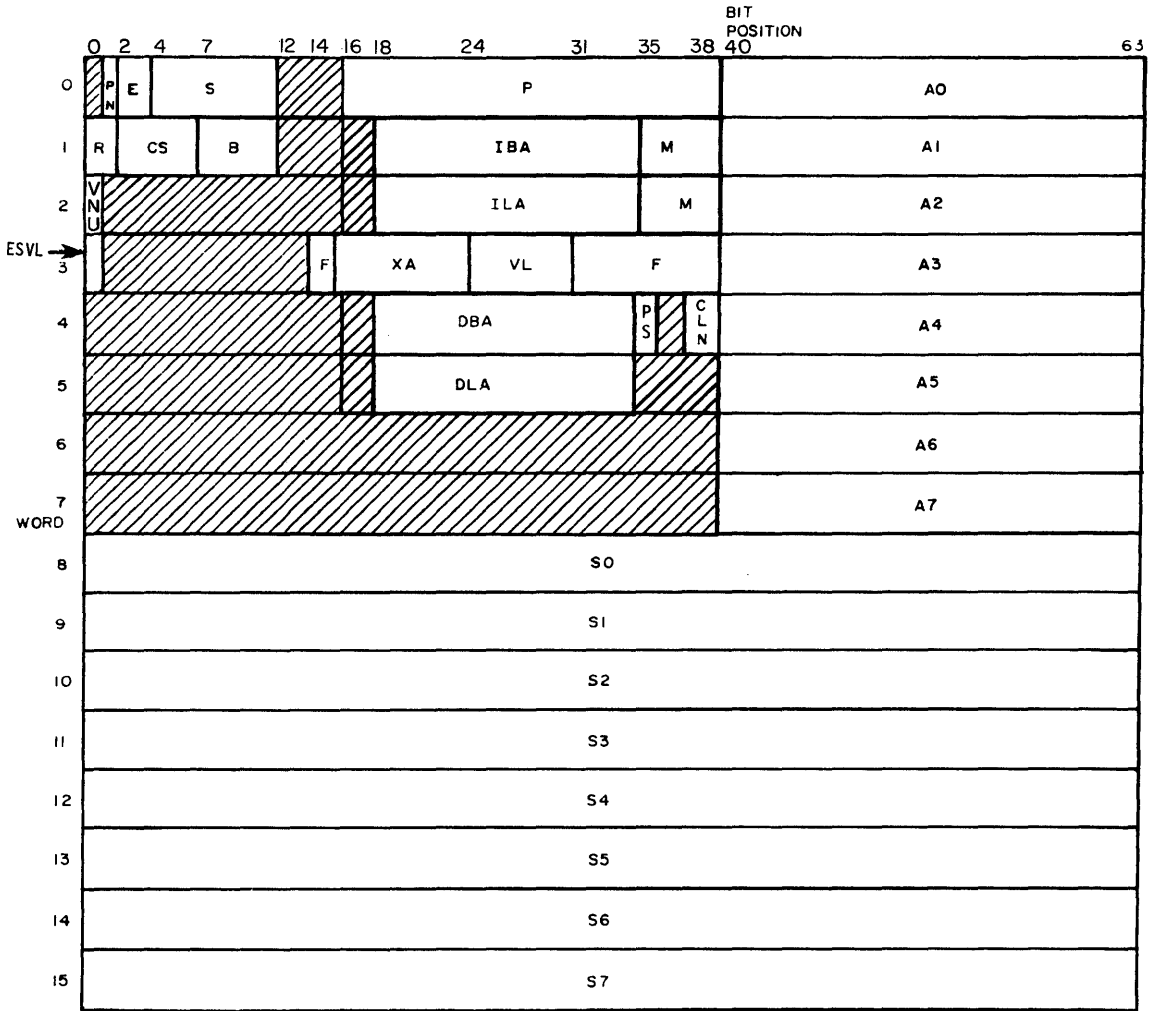

Figure 3-3. Exchange Package for a dual-processor system

Table 3-1. Exchange Package assignments

Field	Word	Bits
Processor number (PN)	0	1
Error type (E)	0	2-3
Syndrome bits (S)	0	4-11
Program Address register (P)	0	16-39
Read mode (R)	1	0-1
Read address (CSB)	1	2-6 (CS);
	1	7-11 (B)
Instruction Base Address (IBA)	1	18-34
Instruction Limit Address (ILA)	2	18-34
Mode register (M)	1-2	35-39
Vector not used (VNU)	2	0
Enable Second Vector Logical (ESVL) [†]	3	0
Flag register (F)	3	14-15;
	3	31-39
Exchange Address register (XA)	3	16-23
Vector Length register (VL)	3	24-30
Data Base Address (DBA)	4	18-34
Program State (PS)	4	35
Cluster Number (CLN)	4	38-39
Data Limit Address (DLA)	5	18-34
Eight A register contents	0-7	40-63
Eight S register contents	8-15	0-63

Processor Number

The content of the processor number (PN) position in the Exchange Package indicates in which CPU the Exchange Package executed. This value is not read into the CPU; it is a constant inserted only into a package being stored.

Vector not used (VNU)

The content of the vector not used (VNU) position in the Exchange Package indicates whether or not instructions 076, 077 or 140 through 177 were issued during the execution intervals. If none of the instructions were issued, the bit is set. If one or more of the instructions issued, the bit is not set.

[†] Not available on all dual-processor systems

Enable Second Vector Logical (ESVL)[†]

The content of the enable second vector logical (ESVL) position in the Exchange Package indicates whether or not the Second Vector Logical unit can be used. If set, instructions 140 through 145 may select the Second Vector Logical unit. If clear, the Second Vector Logical unit cannot be used; only the Full Vector Logical unit may be used.

Memory error data

Bit 36 (interrupt on correctable memory error bit) and bit 38 (interrupt on uncorrectable memory error bit) in the M (mode) register determine if memory error data is included in the Exchange Package. Error data, consisting of four fields of information, appears in the Exchange Package if bit 36 is set and correctable memory error is encountered or if bit 38 is set and an uncorrectable memory error is detected.^{††}

Memory error data fields are described below.

- E (Error type) The type of memory error encountered, uncorrectable or correctable, is indicated in word 0, bits 2 and 3 of the Exchange Package. Bit 2 is set for an uncorrectable memory error; bit 3 is set for a correctable memory error.
- S (Syndrome) The 8 syndrome bits used in detecting a memory data error are returned in word 0, bits 4 through 11 of the Exchange Package. See section 2 for additional information.
- R (Read mode) This field indicates the read mode in progress when a memory data error occurred and is in word 1, bits 0 and 1 of the Exchange Package. These bits assume the following values:
- 00 I/O
 - 01 Scalar (memory references with A or S)
 - 10 Vector, B, or T
 - 11 Instruction fetch or exchange
- CSB (Read address) The 10-bit CSB field contains the address where a memory data error occurred. Word 1, bits 7 through 11 (B) of the Exchange Package contain bits 2⁴ through 2⁰ of the address and can be

[†] Not available on all dual-processor systems

^{††} For multiple bit memory errors, the hardware always sets the Correctable Memory Error flag in the interrupted Exchange Package.

CSB (Read address)
(continued)

considered as the bank address. Word 1, bits 2 through 6 of the Exchange Package contain bits 2^{21} through 2^{17} of the address. For the 12-column mainframe, these bits represent the chip select (CS) of the address; for the 6-column mainframe, only the high order 3 bits of this field can be considered as the chip select (CS).

EXCHANGE REGISTERS

Three special registers are instrumental in the exchange mechanism: the Exchange Address (XA) register, the Mode (M) register, and the Flag (F) register. These three registers are described below.

Exchange Address register

The 8-bit Exchange Address (XA) register specifies the first word address of a 16-word Exchange Package loaded by an exchange operation. The register contains the high-order 8 bits of a 12-bit field specifying the address. The low-order bits of the field are always 0; an Exchange Package must begin on a 16-word boundary. The 12-bit limit requires that the absolute address be in the lower 4096 ($10,000_8$) words of memory.

When an execution interval terminates, the exchange sequence exchanges the contents of the registers with the contents of the Exchange Package at the beginning address (XA) in memory.

Mode register

The 10-bit Mode (M) register contains part of the Exchange Package for a currently active program. The M register bits are assigned in words 1 and 2 of the Exchange Package as follows.

Word 1

<u>Bit</u>	<u>Description</u>
35	Waiting for Semaphore (WS) flag; when set, the CPU exchanged when a test and set instruction was holding in the CIP register.
36	Floating-point Error Status (FPS) flag; when set, a floating-point error has occurred regardless of the state of the Floating-point Error Mode flag.
37	Bidirectional Memory Mode (BDM) flag; when set, block reads and writes can operate concurrently.

Word 1 (continued)

<u>Bit</u>	<u>Description</u>
38	Selected for External Interrupts (SEI) flag; when set, this CPU is preferred for I/O interrupts.
39	Interrupt Monitor Mode (IMM) flag; when set, enables all interrupts in monitor mode except PC, MCU, I/O, and normal exit.

Word 2

<u>Bit</u>	<u>Description</u>
35	Operand Range Error Mode (IOR) flag; when set, enables interrupts on operand range errors.
36	Correctable Memory Error Mode (ICM) flag; when set, enables interrupts on correctable memory data errors.
37	Floating-point Error Mode (IFP) flag; when set, enables interrupts on floating-point errors.
38	Uncorrectable Memory Error Mode (IUM) flag; when set, enables interrupts on uncorrectable memory data errors.
39	Monitor Mode (MM) flag; when set, inhibits all interrupts except memory errors.

The 10 bits are set selectively during an exchange sequence.

Word 1, bit 37 (Bidirectional Memory Mode flag) can be set or cleared by using instructions 002600 (enable bidirectional Memory transfers) and 002500 (disable bidirectional Memory transfers).

Word 2, bit 35 (Operand Range Error Mode flag) can be set or cleared during the execution interval of a program by using instructions 002300 (enable interrupt on operand range error) and 002400 (disable interrupt on operand range error).

Word 2, bit 37 (Floating-point Error Mode flag), can be set or cleared during the execution interval for a program by using instructions 002100 (enable interrupt on floating-point error) and 002200 (disable interrupt on floating-point error).

Word 1, bits 36 and 37 and word 2, bits 35 and 37 can be read with instruction 073i01. Word 1, bits 35 and 36 indicate the state of the CPU at the time of the exchange. The remaining bits are not altered during the execution interval for the Exchange Package and can be altered only when the Exchange Package is inactive in storage.

Flag register

The 11-bit Flag (F) register contains part of the Exchange Package for the currently active program. This register is located in word 3 and contains 11 flags individually identified within the Exchange Package. Setting any of these flags interrupts program execution. When one or more flags are set, a Request Interrupt signal is sent to initiate an exchange sequence. The contents of the F register are stored along with the rest of the Exchange Package. The monitor program can analyze the 11 flags for the cause of the interruption. Before the monitor program exchanges back to the package, it must clear the flags in the F register area of the package. If any bit remains set, another exchange occurs immediately.

The F register bits are assigned in word 3 of the Exchange Package as follows.

Word 3

<u>Bit</u>	<u>Description</u>
14	Interrupt From Internal CPU (ICP) flag; set when the other CPU issues instruction 001401.
15	Deadlock (DL) flag; set when all CPUs in a cluster are holding issue on a test and set instruction.
31	Programmable Clock Interrupt (PCI) flag; set when the interrupt countdown counter in the programmable clock equals 0. The programmable clock is explained later in this section.
32	MCU Interrupt (MCU) flag; set when the MIOP sends this signal.
33	Floating-point Error (FPE) flag; set when a floating-point range error occurs in any of the floating-point functional units and the Enable Floating-point Interrupt flag is set. Floating-point functional units are explained in section 4, computation.
34	Operand Range Error (ORE) flag; set when a data reference is made outside the boundaries of the Data Base Address (DBA) and Data Limit Address (DLA) registers and the Enable Operand Range Interrupt flag is set. Operand range error is explained later in this section.
35	Program Range Error (PRE) flag; set when an instruction fetch is made outside the boundaries of the Instruction Base Address (IBA) and Instruction Limit Address (ILA) registers. Program range error is explained later in this section.

<u>Bit</u>	<u>Description</u>
36	Memory Error (ME) flag; set when a correctable or uncorrectable memory error occurs and the corresponding enable memory error mode bit is set in the M register.
37	I/O Interrupt (IOI) flag; set when a 6 Mbyte channel or the 1250 Mbyte channel completes a transfer.
38	Error Exit (EEX) flag; set by an error exit instruction (000).
39	Normal Exit (NEX) flag; set by a normal exit instruction (004).

Any flag (except the Memory Error flag) can be set in the F register only if the active Exchange Package is not in monitor mode. Such flags are set only if word 2, bit 39 of the M register is 0. Except for the Memory Error flag, if the program is in monitor mode and the conditions for setting an F register are present, the flag remains cleared and no exchange sequence is initiated.

Cluster Number register

The Cluster Number (CLN) register determines the CPU's cluster. The contents of the CLN register are used to determine which set of SB, ST, and SM registers the CPU can access. If the CLN register is 0, then the CPU does not have access to any SB, ST, or SM register. The contents of the CLN registers in both CPUs are also used to determine the condition necessary for a deadlock interrupt.

Program State register

The content of the 1-bit Program State (PS) register is manipulated by the operating system to represent different program states in the CPUs concurrently processing a single program.

A registers

The current contents of all A registers are stored in bits 40 through 63 of word 0 through 7 during exchange.

S registers

The current contents of all S registers are stored in bits 0 through 63 of words 8 through 15 during exchange.

Program Address register

The contents of the Program Address (P) register (address of first program instruction not yet issued) are stored in bits 16 through 39 of word 0. The instruction at this location is the first instruction to be issued when this program begins again.

Memory field registers

Each object program has a designated field of memory for instructions and data that is specified by the monitor program when the object program is loaded and initiated. All memory addresses contained in the object program code are relative to one of two base addresses specifying the beginning of the appropriate field, and limited in size. Each object program reference to memory is checked against the limit and base addresses to determine if the address is within the bounds assigned. These field limits are contained in four registers that are saved in the Exchange Package. The four registers are: the Instruction Base Address (IBA) register, the Instruction Limit Address (ILA) register, the Data Base Address (DBA) register, and the Data Limit Address (DLA) register. Refer to the subsection on Memory Field Protection later in this section for an explanation of the registers.

ACTIVE EXCHANGE PACKAGE

An active Exchange Package resides in the operating registers. The interval of time when the Exchange Package and the program associated with it are active is called the execution interval. An execution interval begins with an exchange sequence where the subject Exchange Package moves from memory to the operating registers. An execution interval ends as the Exchange Package moves back to memory in a subsequent exchange sequence.

EXCHANGE SEQUENCE

The exchange sequence is the vehicle for moving an inactive Exchange Package from memory into the operating registers. At the same time, the exchange sequence moves the currently active Exchange Package from the operating registers back into memory. This swapping operation is done in a fixed sequence when all computational activity associated with the currently active Exchange Package has stopped. The same 16-word block of memory is used as the source of the inactive Exchange Package and the destination of the currently active Exchange Package. Location of this block is specified by the content of the XA register and is a part of the currently active Exchange Package. The exchange sequence can be initiated by deadstart sequence, Interrupt flag set, or program exit.

Exchange initiated by deadstart sequence

The deadstart sequence forces the XA register content to 0 for both CPUs and also forces an interrupt in one CPU. These two actions cause an exchange using memory address 0 as the location of the Exchange Package. The inactive Exchange Package at address 0 then moves into the operating registers and initiates a program using these parameters. The Exchange Package swapped to address 0 is largely indeterminate because of the deadstart operation. New data entered at these storage addresses then discards the old Exchange Package in preparation for starting subsequent CPUs with an interprocessor interrupt.

When instruction 001401 (IP) is issued in the first CPU, the second CPU exchanges to address 0 in memory. (A switch on the mainframe's control panel selects which CPU is deadstarted first.)

Exchange initiated by Interrupt flag set

An exchange sequence can be initiated by setting any one of the Interrupt flags in the F register. Setting of one or more flags causes a Request Interrupt signal to initiate an exchange sequence.

Exchange initiated by program exit

Two program exit instructions initiate an exchange sequence. Timing of the instruction execution is the same in either case; the difference is determined by which of the two flags is set in the F register. The two instructions are:

000	ERR	Error exit
004	EX	Normal exit

The two exits enable a program to request its own termination. A non-monitor (object) program usually uses the normal exit instruction to exchange back to the monitor program. The error exit allows for abnormal termination of an object program. The exchange address selected is the same as for a normal exit.

Each instruction has a flag in the F register. The appropriate flag is set if the currently active Exchange Package is not in monitor mode. The inactive Exchange Package called in this case is normally one that executes in monitor mode. Flags are checked for evaluation of the program termination cause.

The monitor program selects an inactive Exchange Package for activation by setting the address of the inactive Exchange Package in the XA register and then executing a normal exit instruction.

Exchange sequence issue conditions

The following are hold issue conditions, execution time, and special cases for an exchange sequence.

Hold conditions:

- NIP register contains a valid instruction
- S, V, or A registers busy

Execution time:

For 32 banks, 40 CPs; consists of an exchange sequence (24 CPs) and a fetch operation (16 CPs).

For 16 banks, 42 CPs; consists of an exchange sequence (24 CPs) and a fetch operation (18 CPs).

Special cases:

If a test and set instruction is holding in the CIP register, both CIP and NIP registers are cleared and the exchange occurs with the WS (Waiting for Semaphore) flag set and the P register pointing to the test and set instruction.

EXCHANGE PACKAGE MANAGEMENT

Each 16-word Exchange Package resides in an area defined during system deadstart. The defined area must lie within the lower 4096 (10,000g) words of memory. The package at address 0 is the deadstart monitor program's Exchange Package. Other packages provide for object programs and monitor tasks. Non-monitor packages lie outside of the field lengths for the programs they represent as determined by the base and limit addresses for the programs. Only the monitor program has a field defined so that it can access all of memory, including Exchange Package areas. The defined field allows the monitor program to define or alter all Exchange Packages other than its own when it is the currently active Exchange Package. Since no interlock exists between an exchange sequence in a CPU and memory transfers in another CPU, modification of Exchange Packages which can be used by another CPU should be avoided, except under software controlled situations.

Proper management of Exchange Packages dictates that a non-monitor program always exchanges back to the monitor program that exchanged to it. The exchange ensures that the program information is always exchanged into its proper Exchange Package.

For example, the monitor program (A) begins an execution interval following deadstart. No interrupts (except memory) can terminate its execution interval since it is in monitor mode. Program A voluntarily exits by issuing a normal exit instruction (004). However, before doing so, program A sets the contents of the XA register to point to the user program (B) Exchange Package so that program B is the next program to execute. Program A sets the exchange address in program B's Exchange Package to point back to program A.

The exchange sequence to program B causes the exchange address from program B's Exchange Package to be entered in the XA register. At the same time, the exchange address in the XA register goes to program B's Exchange Package area with all other program parameters for program A. When the exchange is complete, program B begins its execution interval.

To illustrate the exchange sequence, assume that while program B is executing, an Interrupt flag sets initiating an exchange sequence. Since program B cannot alter the XA register, the exit is back to program A. Program B's parameters exchange back into its Exchange Package area; program A's parameters held in program B's package area during the execution interval exchange back into the operating registers.

Program A, upon resuming execution, determines an interrupt has caused the exchange and sets the XA register to call the proper interrupt processor into execution. To do this, program A sets XA to point to the Exchange Package for the interrupt processing program (C). Program A clears the interrupt and initiates execution of program C by executing a normal exit instruction (004). Depending on the operating task, program C can execute in monitor mode or in user mode.

Further information on Exchange Package management is contained in the COS EXEC/STP/CSP Internal Reference Manual, publication SM-0040.

MEMORY FIELD PROTECTION

At execution time each object program has a designated field of memory for instructions and data. The field limits are specified by the monitor program when the object program is loaded and initiated. The fields can begin at any word address that is a multiple of 32 (that is, 40g) and can continue to another address that is one less than a multiple of 32. The fields can overlap.

All memory addresses contained in the object program code are relative to one of the two base addresses specifying the beginning of the appropriate field. An object program cannot read or alter any memory location with an absolute address lower than that base address. Each object program reference to memory is checked against the limit and base addresses to determine if the address is within the bounds assigned. A memory read

reference beyond the assigned field limits issues and completes, but a zero value is transferred from memory. A memory write reference beyond the assigned field limits is allowed to issue, but no write occurs.

Field limits are contained in four registers: the Instruction Base Address (IBA) register, the Instruction Limit Address (ILA) register, the Data Base Address (DBA) register, and the Data Limit Address (DLA) register. These four registers and flags associated with the field limits are described in the following paragraphs.

INSTRUCTION BASE ADDRESS REGISTER

The Instruction Base Address (IBA) register holds the base address of the user's instruction field. An instruction can only be executed by the CPU if the absolute address at which the instruction is located is greater than or equal to the contents of the current Exchange Package IBA register of the program executing. This determination is made at instruction buffer fetch time by the CPU.

The contents of the IBA register are interpreted as the high-order 17 bits of a 22-bit memory address. The low-order 5 bits of the address are assumed to be 0 because of the number of banks, 32 (decimal) banks. Absolute memory addresses for an instruction fetch are formed by adding the IBA register to the P register (high-order 22 bits) modulo two to the twenty-second power.

A reference to an absolute address less than the address defined by IBA can only occur through a jump or branch instruction to an address beyond the memory capacity of the machine.

INSTRUCTION LIMIT ADDRESS REGISTER

The Instruction Limit Address (ILA) register holds the limit address of the user's field. An instruction can only be executed by the CPU if the absolute address where it is located is less than the contents of the current Exchange Package ILA register of the program executing. This determination is made at instruction buffer fetch time by the CPU.

The contents of the ILA register are interpreted as the high-order 17 bits of a 22-bit memory address. The low-order 5 bits of the address are assumed to be 0 because of the number of banks, 32 (decimal) banks. The largest absolute address that can be executed by a program is defined by $[(ILA) \times 2^5] - 1$.

If the final absolute address of the instruction buffer fetch as computed by the CPU does not fall between the range of addresses contained within the currently executing Exchange Package IBA and ILA registers, the CPU generates a program range error interrupt.

DATA BASE ADDRESS REGISTER

The Data Base Address (DBA) register holds the base address of the user's data field. An operand can only be fetched or stored by the CPU if the absolute address where the operand is located is greater than or equal to the contents of the current Exchange Package DBA register of the program executing. This determination is made each time an operand is fetched or stored by the CPU.

The contents of the DBA register are interpreted as the high-order 17 bits of a 22-bit memory address. The low-order 5 bits of the DBA register are assumed to be 0. Absolute memory addresses for operands are formed by adding the DBA register to the modified operand address modulo two to the twenty-second power.

DATA LIMIT ADDRESS REGISTER

The Data Limit Address (DLA) register holds the (upper) limit address of the user's data field. An operand can only be fetched or stored by the CPU if the absolute address where the operand is located is less than the contents of the current Exchange Package DLA register of the program executing. This determination is made each time an operand is fetched or stored by the CPU.

The contents of the DLA register are interpreted as the high-order 17 bits of a 22-bit memory address. The low-order 5 bits of the DLA register are assumed to be 0. The largest absolute address that can be referenced for data by a program is defined by $[(DLA) \times 2^5] - 1$.

If the final absolute address of the operand as computed by the CPU does not fall between the range of addresses contained within the currently executing Exchange Package DBA and DLA registers, the CPU generates an operand (address) range error interrupt.

PROGRAM RANGE ERROR

The Program Range Error flag sets if a memory reference outside the boundaries of the IBA and ILA registers is for an instruction fetch. An out-of-range memory reference can occur in a non-monitor mode program on a branch or jump instruction calling for a program address above or below the limits. The Program Range Error flag causes an error condition that terminates program execution. The monitor program checks the state of the Program Range Error flag and takes appropriate action, perhaps aborting the user program.

OPERAND RANGE ERROR

The Operand Range Error flag sets if the Operand Range Error Mode flag is set and a memory reference outside the boundaries of the DBA and DLA registers is called to read or write an operand for an A, B, S, T, or V register and the Operand Range Interrupt Error flag is set. The Operand Range Error flag causes an error condition that terminates the user program execution. The monitor program checks the state of the Operand Range Error flag and takes appropriate action, perhaps aborting the user program.

PROGRAMMABLE CLOCK

The programmable clock can be used to accurately measure the duration of intervals. Intervals selected under monitor program control generate a periodic interrupt. The clock frequency is 105 Mhz. Intervals from 9.5 nanoseconds to approximately 40.8 seconds are possible. Intervals shorter than 100 microseconds are not practical due to the monitor overhead involved in processing the interrupt. Supporting the programmable clock are the Interrupt Interval (II) register, the Interrupt Countdown (ICD) counter, and four monitor mode instructions.

INSTRUCTIONS

Four monitor mode instructions support the programmable clock:

0014j4	PCI S _j	Enter Interrupt Interval (II) register with (S _j)
001405	CCI	Clear the programmable clock interrupt request
001406	ECI	Enable the programmable clock interrupt request
001407	DCI	Disable the programmable clock interrupt request

INTERRUPT INTERVAL REGISTER

The 32-bit Interrupt Interval (II) register can be loaded with a binary value equal to the number of CPs that are to elapse between programmable clock interrupt requests. The interrupt interval is transferred from the low-order 32 bits of the S_j register into the II register and the ICD counter when instruction 0014j4 is executed.

This value is held in the II register and is transferred to the ICD counter each time the counter reaches 0 and generates an interrupt request. The content of the II register is changed only by another instruction 0014j4.

INTERRUPT COUNTDOWN COUNTER

The 32-bit Interrupt Countdown (ICD) counter is preset to the contents of the II register when instruction 0014j4 is executed. This counter runs continuously but counts down, decrementing by 1 each CP until the content of the counter is 0. The ICD sets the programmable clock interrupt request and samples the interval value held in the II register. The ICD repeats the countdown to zero cycle, setting the programmable clock interrupt request at regular intervals determined by the interval value.

When the programmable clock interrupt request is set, it remains set until a clear programmable clock interrupt request is executed. A programmable clock interrupt request can be set only after the enable programmable clock interrupt request is executed. A programmable clock interrupt request causes an interrupt only when not in monitor mode. A request set in monitor mode is held until the system switches to user mode.

CLEAR PROGRAMMABLE CLOCK INTERRUPT REQUEST

Following a program interrupt interval, an active programmable clock interrupt request can be cleared by executing instruction 001405.

Following any deadstart, the monitor program should ensure the state of the programmable clock interrupt by issuing instructions 001405 and 001407.

PERFORMANCE MONITOR

The system contains a set of eight performance counters to track certain hardware related events that can be used to indicate relative performance. The events that can be tracked are the number of specific instructions issued, hold issue conditions, the number of fetches, references, etc. and are selected through instruction 0015j0. Refer to Appendix C for complete information on performance monitoring.

DEADSTART SEQUENCE

The deadstart sequence of operations starts a program running in the mainframe after power has been turned off and then turned on again or whenever the operating system is to be reinitialized in the mainframe. All registers in the machine, all control latches, and all words in memory should be considered invalid after power has been turned on. The following sequence of operations to begin the program is initiated by the I/O Subsystem.

1. Turn on Master Clear signal.
2. Turn on I/O Clear signal.
3. Turn off I/O Clear signal.
4. Load memory via I/O Subsystem.
5. Turn off Master Clear signal.

The Master Clear signal halts all internal computation and forces critical control latches to predetermined states. The I/O Clear signal clears the input Channel Address register of the MCU channel and activates the MCU input channel. All other input channels remain inactive. The I/O Subsystem then loads an initial Exchange Package and monitor program. The Exchange Package must be located at address 0 in memory. Turning off the Master Clear signal initiates the exchange sequence to read this package and to begin execution of the monitor program in CPU 0 (PN=0).

CPU 1 (PN=1) remains in a master-cleared state until instruction 001401 (IP) is issued in CPU 0. Then CPU 1 exchanges to address 0 in memory.

Because the exchange of CPU 0 overwrites the contents of the inactive Exchange Package at address 0, CPU 0 must reinitialize the Exchange Package at address 0 before allowing other CPUs to start. (Either CPU can be started first by using a switch on the mainframe's control panel.) Subsequent actions are dictated by the design of the operating system.

INTRODUCTION

Each CPU contains an identical, independent computation section. A computation section consists of operating registers and functional units associated with three types of processing: address, scalar, and vector. Address processing operates on internal control information such as addresses and indexes and has two levels of 24-bit registers and two integer arithmetic functional units. Scalar and vector processing are performed on data.

A vector is an ordered set of elements. A vector instruction operates on a series of elements repeating the same function and producing a series of results. Scalar processing starts an instruction, handles one operand or operand pair, and produces a single result.

The main advantage of vector over scalar processing is eliminating instruction start-up time for all but the first operand. Scalar processing has two levels of 64-bit scalar registers, four functional units dedicated solely to scalar processing, and three floating-point functional units shared with vector operations. Vector processing has a set of 64-element registers of 64 bits each, four[†] functional units dedicated solely to vector applications, and three floating-point functional units supporting both scalar and vector operations.

Address information flows from Central Memory or from control registers to address registers. Information in the address registers is distributed to various parts of the control network for use in controlling the scalar, vector, and I/O operations. The address registers can also supply operands to two integer functional units. The units generate address and index information and return the result to the address registers. Address information can also be transmitted to Central Memory from the address registers.

Data flow in a computation section is from Central Memory to registers and from registers to functional units. Results flow from functional units to registers and from registers to Central Memory or back to functional units. Data flows along either the scalar or vector path depending on the processing mode. An exception is that scalar registers can provide one required operand for vector operations performed in the vector functional units.

[†] Five vector functional units are available on systems with a Second Vector Logical unit.

Integer or floating-point arithmetic operations are performed in the computation section. Integer arithmetic is performed in twos complement mode. Floating-point quantities have signed magnitude representation.

Floating-point instructions provide for addition, subtraction, multiplication, and reciprocal approximation. The reciprocal approximation instructions provide for a floating-point divide operation using a multiple instruction sequence. These instructions produce 64-bit results (1-bit sign, 15-bit exponent, and 48-bit normalized coefficient).

Integer or fixed-point operations are integer addition, integer subtraction, and integer multiplication. Integer addition and subtraction operations produce either 24-bit or 64-bit results. An integer multiply operation produces a 24-bit result. A 64-bit integer multiply operation is done through a software algorithm using the floating-point multiply functional unit to generate multiple partial products. These partial products are then shifted and merged to form the full 64-bit product. No integer divide instruction is provided; the operation is accomplished through a software algorithm using floating-point hardware.

The instruction set includes Boolean operations for OR, AND, equivalence, and exclusive OR and for a mask-controlled merge operation. Shift operations allow the manipulation of either 64-bit or 128-bit operands to produce 64-bit results. With the exception of 24-bit integer arithmetic, most operations are implemented in vector and scalar instructions. The integer product is a scalar instruction designed for index calculation. Full indexing capability allows the programmer to index throughout memory in either scalar or vector modes. The index can be positive or negative in either mode. Indexing allows matrix operations in vector mode to be performed on rows or the diagonal as well as conventional column-oriented operations.

Population and parity counts are provided for both vector and scalar operations. An additional scalar operation is the leading zero count.

Characteristics of a CPU computation section are summarized below.

- Integer and floating-point arithmetic
- Twos complement integer arithmetic
- Signed magnitude floating-point arithmetic
- Address, scalar, and vector processing modes
- Thirteen functional units
- Eight 24-bit address (A) registers
- Sixty-four 24-bit intermediate address (B) registers
- Eight 64-bit scalar (S) registers
- Sixty-four 64-bit intermediate scalar (T) registers
- Eight 64-element vector (V) registers, 64 bits per element

OPERATING REGISTERS

Operating registers, a primary programmable resource of a CPU, enhance the speed of the system by satisfying heavy demands for data made by the functional units. A single functional unit can require one to three operands per clock period (CP) to perform the necessary functions and can deliver results at a rate of one per CP. Multiple functional units can be used concurrently.

A CPU has three primary and two intermediate sets of registers. The primary sets of registers are address, scalar, and vector, designated in this manual as A, S, and V, respectively. These registers are considered primary because functional units can access them directly.

For the A and S registers, an intermediate level of registers exists which is not accessible to the functional units but acts as a buffer for the primary registers. Block transfers are possible between these registers and Central Memory so that the number of memory reference instructions required for scalar and address operands is greatly reduced. The intermediate registers that support the A registers are referred to as B registers. The intermediate registers that support S registers are referred to as T registers.

ADDRESS REGISTERS

Figure 4-1 illustrates registers and functional units used for address processing. The two types of address registers are designated A registers and B registers and are described in the following paragraphs.

A REGISTERS

Eight 24-bit A registers serve a variety of applications but are primarily used as address registers for memory references and as index registers. They provide values for shift counts, loop control, and channel I/O operations and receive values of population count and leading zeros count. In address applications, A registers index the base address for scalar memory references and provide both a base address and an address increment for vector memory references.

The address functional units support address and index generation by performing 24-bit integer arithmetic on operands obtained from A registers and by delivering the results to A registers.

Data is moved directly between Central Memory and A registers or is placed in B registers. Placing data in B registers allows buffering of

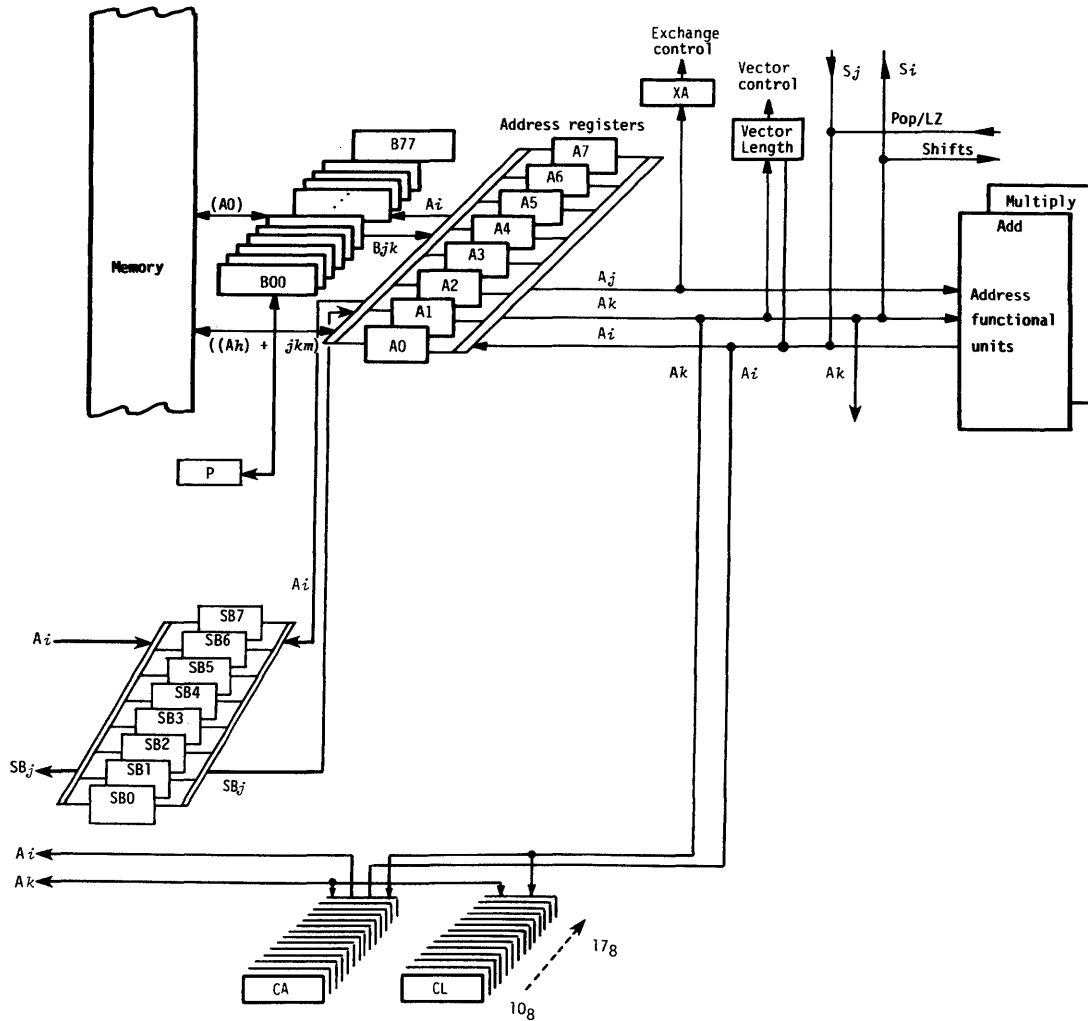

Figure 4-1. Address registers and functional units

the data between A registers and Central Memory. Data can also be transferred between A and S registers and between A and Shared Address (SB) registers.

The Vector Length (VL) register and Exchange Address (XA) register are set by transmitting a value to them from an A register. The VL register can also be transmitted to an A register. (The VL register is described under Vector Control Registers later in this section.)

When an issued instruction delivers new data to an A register, a reservation is set for that register. The reservation prevents issue of instructions that use the register until the new data is delivered.

In this manual, the A registers are individually referred to by the letter A followed by a number ranging from 0 through 7. Instructions reference A registers by specifying the register number as the *h*, *i*, *j*, or *k* designator as described in section 5.

The only register implicitly referenced is the A0 register as illustrated in the following instructions:

010	<i>ijklm</i>	JAZ	<i>exp</i>	Branch to <i>ijklm</i> if (A0)=0
011	<i>ijklm</i>	JAN	<i>exp</i>	Branch to <i>ijklm</i> if (A0)≠0
012	<i>ijklm</i>	JAP	<i>exp</i>	Branch to <i>ijklm</i> if (A0) is positive, includes (A0)=0
013	<i>ijklm</i>	JAM	<i>exp</i>	Branch to <i>ijklm</i> if (A0) is negative
034	<i>ijk</i>	B <i>jk</i> ,A <i>i</i>	,A0	Read (A <i>i</i>) words to B register <i>jk</i> from (A0)
035	<i>ijk</i>	,A0	B <i>jk</i> ,A <i>i</i>	Store (A <i>i</i>) words at B register <i>jk</i> to (A0)
036	<i>ijk</i>	T <i>jk</i> ,A <i>i</i>	,A0	Read (A <i>i</i>) words to T register <i>jk</i> from (A0)
037	<i>ijk</i>	,A0	T <i>jk</i> ,A <i>i</i>	Store (A <i>i</i>) words at T register <i>jk</i> to (A0)
176	<i>i0k</i>	V <i>i</i>	,A0,A <i>k</i>	Read (VL) words to V <i>i</i> from (A0) incremented by (A <i>k</i>)
1770	<i>jk</i>	,A0,A <i>k</i>	V <i>j</i>	Store (VL) words from V <i>j</i> to (A0) incremented by (A <i>k</i>)

Section 5 of this manual contains additional information on the use of A registers by instructions.

B REGISTERS

A computation section contains sixty-four 24-bit B registers used as intermediate storage for the A registers. Typically, B registers contain data to be referenced repeatedly over a sufficiently long span, making it unnecessary to retain the data in either A registers or in Central Memory. Examples of uses are loop counts, variable array base addresses, and dimensions.

Transfer of a value between an A register and a B register requires only 1 CP. A block of B registers can be transferred to or from Central Memory at the maximum rate of one 24-bit value per CP. A reservation is made on all B registers during block transfers to and from B registers.

NOTE

Other instructions can issue on the CRAY X-MP while a block of B registers is being transferred to or from Central Memory.

In this manual, B registers are individually referred to by the letter B followed by a 2-digit octal number ranging from 00 through 77. Instructions reference B registers by specifying the B register number in the *jk* designator as described in section 5.

The only B register implicitly referenced is the B00 register. On execution of the return jump instruction, $007ijkm$, register B00 is set to the next instruction parcel address (P) and a branch to an address specified by *ijkm* occurs. Upon receiving control, the called routine conventionally saves (B00) so that the B00 register is available for the called routine to initiate return jumps of its own. When a called routine wishes to return to its caller, it restores the saved address and executes instruction $0050jk$. Conventionally, this instruction, which is a branch to (Bjk), causes the address saved in Bjk to be entered into the P register as the address of the next instruction parcel to be executed.

SCALAR REGISTERS

Figure 4-2 illustrates registers and functional units used for scalar processing. The two types of scalar registers are designated S registers and T registers and are described in the following paragraphs.

S REGISTERS

Eight 64-bit S registers are the principal scalar registers for a CPU serving as the source and destination for operands executing scalar arithmetic and logical instructions. Scalar functional units perform both integer and floating-point arithmetic operations.

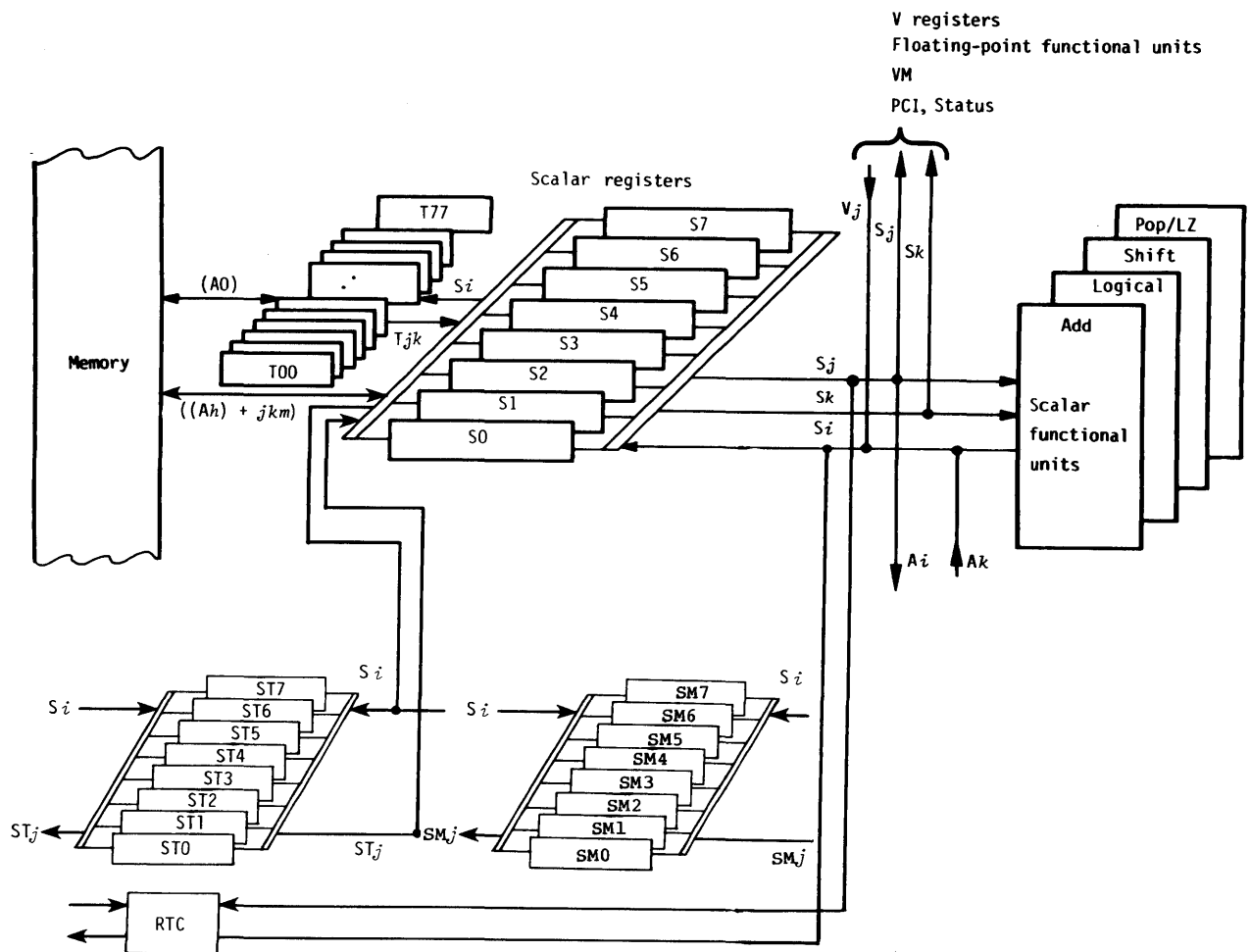

Figure 4-2. Scalar registers and functional units

S registers can furnish one operand in vector instructions. Single-word transmissions of data between an S register and an element of a V register are also possible.

Data is moved directly between Central Memory and S registers or is placed in T registers. This intermediate step allows buffering of scalar operands between S registers and Central Memory. Data is also transferred between A and S registers, between S and Shared Scalar (ST) registers, and between S and Semaphore (SM) registers.

Other uses of the S registers are the setting or reading of the Vector Mask (VM) register or the Real-time Clock (RTC) register or setting the Interrupt Interval (II) register.

When an issuing instruction delivers new data to an S register, a reservation is set for that register preventing issue of instructions that read the register until the new data is delivered.

In this manual, the S registers are individually referred to by the letter S followed by a number ranging from 0 through 7. Instructions reference S registers by specifying the register number as the *i*, *j*, or *k* designator as described in section 5.

The only register implicitly referenced is the S0 register as illustrated in the following instructions.

014	<i>ijkm</i>	JSZ	<i>exp</i>	Branch to <i>ijkm</i> if (S0)=0
015	<i>ijkm</i>	JSN	<i>exp</i>	Branch to <i>ijkm</i> if (S0)≠0
016	<i>ijkm</i>	JSP	<i>exp</i>	Branch to <i>ijkm</i> if (S0) is positive, includes (S0)=0
017	<i>ijkm</i>	JSM	<i>exp</i>	Branch to <i>ijkm</i> if (S0) is negative
052	<i>ijk</i>	S0	<i>Si</i> < <i>exp</i>	Shift (<i>Si</i>) left <i>jk</i> places to S0
053	<i>ijk</i>	S0	<i>Si</i> > <i>exp</i>	Shift (<i>Si</i>) right <i>jk</i> places to S0

The 8-bit Status register provides the status of the following flags:

- Processor Number (PN)
- Program State (PS)
- Cluster Number (CN)
- Floating-point Interrupts Enabled (IFP)
- Floating-point Error (FPE)
- Bidirectional Memory Enabled (BDM)
- Operand Range Interrupts Enabled (IOR)

Instruction 073 sends the contents of the Status register to an S register.

Section 5 of this manual has additional information on the use of S registers by instructions.

T REGISTERS

The computation section has sixty-four 64-bit T registers used as intermediate storage for the S registers. Data is transferred between T and S registers and between T registers and Central Memory. Transfer of a value between a T register and an S register requires only 1 CP.

T registers reference Central Memory through block read and block write instructions. Block transfers occur at a maximum rate of one word per CP. A reservation is made on all T registers during block transfers to and from T registers.

NOTE

Other instructions can issue on the CRAY X-MP while a block of T registers is being transferred to or from Central Memory.

In this manual, T registers are referred to by the letter T and a 2-digit octal number ranging from 00 through 77. Instructions reference T registers by specifying the octal number as the *jk* designator as described in section 5.

VECTOR REGISTERS

Figure 4-3 illustrates the registers and functional units used for vector operations. Vector registers and Vector Control registers are described in the following paragraphs.

V REGISTERS

The major computational registers of a CPU are eight V registers, each with 64 elements. Each V register element has 64 bits. When associated data is grouped into successive elements of a V register, the register quantity can be treated as a vector. Examples of vector quantities are rows or columns of a matrix or elements of a table. Computational efficiency is achieved by identically processing each element of a vector. Vector instructions provide for the iterative processing of successive V register elements. A vector operation always begins when operands are obtained from the first element of the operand V registers and the result is delivered to the first element of a V register. Successive elements are provided each CP and as each operation is performed, the result is delivered to successive elements of the result V register. The vector operation continues until the number of operations performed by the instruction equals a count specified by the content of the VL register.

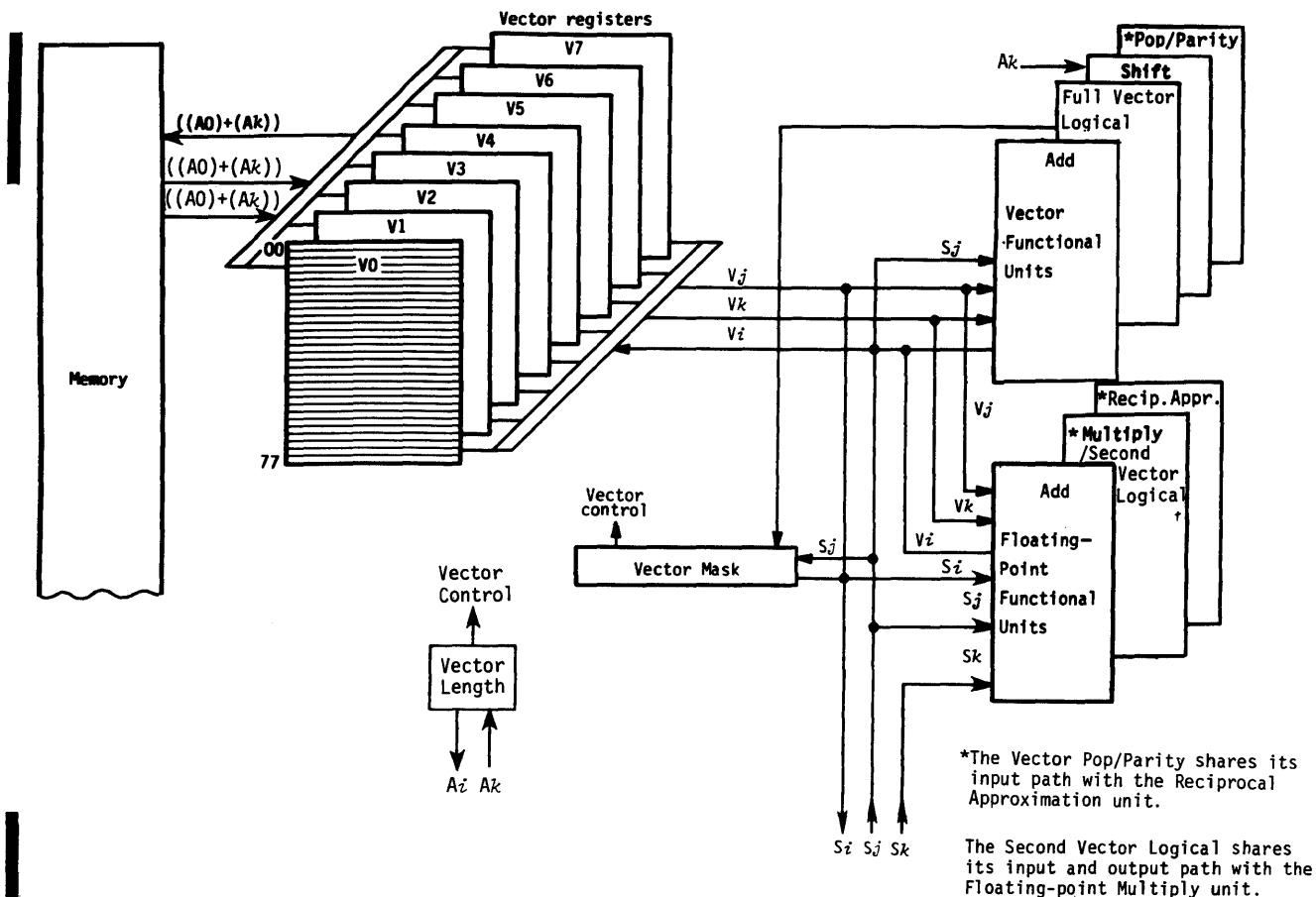

Figure 4-3. Vector registers and functional units

Contents of a V register are transferred to or from Central Memory in a block mode by specifying a first word address in Central Memory, an increment or decrement for the Central Memory address, and a vector length. The transfer then proceeds beginning with the first element of the V register at a maximum rate of one word per CP, depending upon bank conflicts. Discontinuities in the vector data stream can occur as a result of memory conflicts. These discontinuities, although not inhibiting chained operations, can appear in the chained operation data stream. Any discontinuity in the data stream adds proportionally to the total execution time of the vector operation.

Single-word data transfers are possible between an S register and an element of a V register.

† On systems equipped with a Second Vector Logical functional unit

Since many vectors exceed 64 elements, a long vector is processed as one or more 64-element segments and a possible remainder of less than 64 elements. Generally, it is convenient to compute the remainder and process this short segment before processing the remaining number of 64-element segments. However, a programmer can choose to construct the vector loop code in a number of ways. The processing of long vectors in FORTRAN is handled by the compiler and is transparent to the programmer.

A V register receiving results can also supply operands to a subsequent operation. Using a register as both a result and operand register in two different operations allows for the chaining together of two or more vector operations and two or more results can be produced per CP. Chained operations are detected automatically by a CPU and are not explicitly specified by the programmer. A programmer can reorder certain code segments to gain as much concurrency as possible in chained operations.

A conflict can occur between vector and scalar operations involving floating-point operations and memory access. With the exception of these operations, the functional units are always available for scalar operations. A vector operation occupies the selected functional unit until the vector is processed.

Parallel vector operations can be processed in two ways:

- Using different functional units and all different V registers
- Using the result stream from one V register simultaneously as the operand to another operation using a different functional unit (chain mode)

Parallel operations on vectors allow the generation of two or more results per CP. Most vector operations use two V registers as operands or one S and one V register as operands. Exceptions are vector shifts, vector logicals, vector reciprocals, and the load or store instructions.

In this manual, the V registers are individually referred to by the letter V followed by a number ranging from 0 through 7. Vector instructions reference V registers by specifying the register number as the *i*, *j*, or *k* designator as described in section 5.

Individual elements of a V register are designated in this manual by decimal numbers ranging from 00 through 63. These appear as subscripts to vector register references. For example, V₆₂₉ refers to element 29 of V register 6.

NOTE

Parallel loading and storing of V registers is possible; two load operations and one store operation can occur simultaneously.

V register reservations and chaining

Reservation describes the condition of a register in use; that is, the register is not available for another operation as a result or as an operand register. Each register has two reservation conditions, one reserving it as a operand register and one reserving it as a result register. During execution of a vector instruction, reservations are placed on the operand V registers and on the result V register. These reservations are placed on the registers themselves, not on individual elements of the V register.

If a V register is reserved as a result and not as an operand, it can be used at any time as an operand and chaining occurs. This flexible chaining mechanism allows chaining to begin at any point in the result vector data stream. Full chaining occurs if the instruction causing chaining is issued before or at the time element 0 of the result arrives at the V register. Partial chaining occurs if the instruction issues after the arrival of element 0. Thus, the amount of concurrency in a chained operation depends upon the relationship between the issue time of the chaining instruction and the result vector data stream.

If a V register is reserved as an operand, it cannot be used as a result or operand register until the operand reservation clears. However, a V register can be used as both an operand and result in the same vector operation. A V register can serve only one vector operation as the source of one or both operands. A V register can serve only one vector operation as a result.

No reservation is placed on the VL register during vector processing. If a vector instruction employs an S register, no reservation is placed on the S register. The S register can be modified in the next instruction after vector issue without affecting the vector operation. The length and scalar operand (if appropriate) of each vector operation is maintained apart from the VL register and S register. Vector operations employing different lengths can proceed concurrently.

The A0 and A_k registers in a vector memory reference are treated similarly and are available for modification immediately after use.

CAUTION

Cray Research, Inc., cautions against using a vector register as both a result and an operand if compatibility between a CRAY-1 and a CRAY X-MP system is necessary because vector recursion is not available on all Cray Research, Inc., computers.

VECTOR CONTROL REGISTERS

The Vector Length (VL) register and Vector Mask (VM) register provide control information needed in the performance of vector operations and are described below.

Vector Length register

The 7-bit Vector Length (VL) register is set to 1 through 100_g (VL = 0 gives VL = 100_g) specifying the length of all vector operations performed by vector instructions and the length of the vectors held by the V registers. The VL register controls the number of operations performed for instructions 140 through 177 and is set to an A register value using instruction 0020 or read using instruction 023i01.

Vector Mask register

The Vector Mask (VM) register has 64 bits, each corresponding to a word element in a V register. Bit 2⁶³ corresponds to element 0, bit 2⁰ to element 63. The mask is used with vector merge and test instructions to allow operations to be performed on individual vector elements.

The VM register can be set from an S register through instruction 003 or can be created by testing a V register for a condition using instruction 175. The mask controls element selection in the vector merge instructions (146 and 147). Instruction 073 sends the contents of the VM register to an S register.

FUNCTIONAL UNITS

Instructions other than simple transmits or control operations are performed by specialized hardware known as functional units. Each unit implements an algorithm or a portion of the instruction set. Functional units have independent logic except for the Reciprocal Approximation, and Vector Population Count units (described later in this section), which share some logic. (On systems equipped with a Second Vector Logical functional unit, the Floating-point Multiply and Second Vector Logical units share input and output paths.) All functional units can be in operation at the same time.

A functional unit receives operands from registers and delivers the result to a register when the function has been performed. Functional units operate essentially in 3-address mode with source and destination addressing limited to register designators.

All functional units perform algorithms in a fixed amount of time; delays are impossible once the operands have been delivered to the unit. Time required from delivery of the operands to the functional unit until completion of the calculation is called the functional unit time and is measured in 9.5-nanosecond CPs.

Functional units are fully segmented. This means a new set of operands for unrelated computation can enter a functional unit each CP even though the functional unit time can be more than 1 CP. This segmentation is possible when information arrives at the functional unit and is held in the functional unit or moves within the functional unit at the end of every CP.

The functional units identified in this manual are arbitrarily described in four groups: address, scalar, vector, and floating-point. Each of the first three groups functions with one of the primary register types (A, S, and V) to support the address, scalar, and vector modes of processing available in the mainframe. The fourth group, floating-point, supports either scalar or vector operations and accepts operands from or delivers results to S or V registers. In addition, Central Memory can also act as a functional unit for vector operations.

ADDRESS FUNCTIONAL UNITS

Address functional units perform 24-bit integer arithmetic on operands obtained from A registers and deliver the results to an A register. The arithmetic is twos complement.

Address Add functional unit

The Address Add functional unit performs 24-bit integer addition and subtraction. The unit executes instructions 030 and 031. Addition and subtraction are performed in a similar manner. The two's complement subtraction for instruction 031 occurs when the one's complement of the A_k operand is added to the A_j operand. Then a 1 is added in the low-order bit position of the result. No overflow is detected in the Address Add functional unit.

The Address Add functional unit time is 2 CPs.

Address Multiply functional unit

The Address Multiply functional unit executes instruction 032 forming a 24-bit integer product from two 24-bit operands. No rounding is performed. The result consists of the least significant 24 bits of the product.

This functional unit is designed to handle address manipulations not exceeding its data capabilities. The programmer must be careful when multiplying integers in the functional unit because the unit does not detect overflow of the product and significant portions of the product could be lost.

The Address Multiply functional unit time is 4 CPs.

SCALAR FUNCTIONAL UNITS

Scalar functional units perform operations on 64-bit operands obtained from S registers and, in most cases, deliver the 64-bit results to an S register. The exception is the Population/Leading Zero Count functional unit which delivers its 7-bit result to an A register.

Four functional units are exclusively associated with scalar operations and are described below. Three functional units are used for both scalar and vector operations and are described in the section on Floating-point Functional Units.

Scalar Add functional unit

The Scalar Add functional unit performs 64-bit integer addition and subtraction and executes instructions 060 and 061. Addition and subtraction are performed in a similar manner. The two's complement subtraction for instruction 061 occurs when the one's complement of the S_k operand is added to the S_j operand. Then a 1 is added in the

low-order bit position of the result. No overflow is detected in the Scalar Add functional unit.

The Scalar Add functional unit time is 3 CPs.

Scalar Shift functional unit

The Scalar Shift functional unit shifts the entire 64-bit contents of an S register or shifts the double 128-bit contents of two concatenated S registers. Shift counts are obtained from an A register or from the *jk* portion of the instruction. Shifts are end off with zero fill. For a double shift, a circular shift is effected if the shift count does not exceed 64 and the *i* and *j* designators are equal and nonzero.

The Scalar Shift functional unit executes instructions 052 through 057. Single-shift instructions (052 through 055) have a functional unit time of 2 CPs. Double-shift instructions (056 and 057) have a functional unit time of 3 CPs.

Scalar Logical functional unit

The Scalar Logical functional unit performs bit-by-bit manipulation of 64-bit quantities obtained from S registers. It executes instructions 042 through 051, the mask, and Boolean instructions. Instructions 042 through 051 have a functional unit time of 1 CP.

Scalar Population/Parity/Leading Zero functional unit

This functional unit executes instructions 026 and 027. Instruction 026 $i,j0$ counts the number of bits in an S register having a value of 1 in the operand and has a functional unit time of 4 CPs. Instruction 026 $i,j1$ returns a 1-bit population parity count (even parity) of the S_j register's contents. Instruction 027 counts the number of bits of 0 preceding a 1 bit in the operand and has a functional unit time of 3 CPs. For these instructions, the 64-bit operand is obtained from an S register and the 7-bit result is delivered to an A register.

VECTOR FUNCTIONAL UNITS

Most vector functional units perform operations on operands obtained from one or two V registers or from a V register and an S register. The Reciprocal, Shift, and Population/Parity functional units, which require only one operand, are exceptions. Results from a vector functional unit are delivered to a V register.

Successive operand pairs are transmitted each CP to a functional unit. The corresponding result emerges from the functional unit n CPs later, where n is the functional unit time and is constant for a given functional unit. The VL register determines the number of operand pairs to be processed by a functional unit.

The functional units described in this section are exclusively associated with vector operations. Three functional units are associated with both vector operations and scalar operations and are described in the subsection entitled Floating-point Functional Units. When a floating-point functional unit is used for a vector operation, the general description of vector functional units given in the subsection applies.

Vector functional unit reservation

A functional unit engaged in a vector operation remains busy during each CP and cannot participate in other operations. In this state, the functional unit is reserved. Other instructions requiring the same functional unit will not issue until the previous operation is completed. Only one functional unit of each type is available to the vector instruction hardware (with the exception of systems equipped with a Second Vector Logical unit where instructions 140 to 145 may use either of the vector logical units). When the vector operation completes, the reservation is dropped and the functional unit is then available for another operation. A vector functional unit is reserved for $(VL) + 4$ CPs.

Vector Add functional unit

The Vector Add functional unit performs 64-bit integer addition and subtraction for a vector operation and delivers the results to elements of a V register. The unit executes instructions 154 through 157. Addition and subtraction are performed in a similar manner. For subtraction operations (156 and 157), the V_k operand is complemented before addition and a 1 is added into the low-order bit position of the result. No overflow is detected by the unit.

The Vector Add functional unit time is 3 CPs.

Vector Shift functional unit

The Vector Shift functional unit shifts the entire 64-bit contents of a V register element or the 128-bit value formed from two consecutive elements of a V register. Shift counts are obtained from an A register and are end off with zero fill.

All shift counts are considered positive unsigned integers. If any bit higher than 2^6 is set, the shifted result is all zeros.

The Vector Shift functional unit executes instructions 150 through 153. The functional unit time is 4 CPs for instruction 152, and the functional unit time is 3 CPs for instructions 150, 151, and 153.

Full Vector Logical functional unit

The Full Vector Logical functional unit performs a bit-by-bit manipulation of the 64-bit quantities for instructions 140 through 147. The Full Vector Logical functional unit also performs the logical operations associated with the vector mask instruction 175. Because instruction 175 uses the same functional unit as instructions 140 through 147, it cannot be chained with these instructions.

NOTE

If the system is equipped with a Second Vector Logical unit and the unit is enabled, it is possible for instruction 175 to be chained with instructions 140 through 145. In order for this to happen however, the 140 through 145 instructions must use the Second Vector Logical functional unit and not the Full Vector Logical unit.

The Full Vector Logical functional unit time is 2 CPs.

Second Vector Logical functional unit[†]

The Second Vector Logical functional unit performs a bit-by-bit manipulation of the 64 bit quantities for instructions 140 through 145. At the time of CIP for a 140 through 145 instruction, a selection is made as to which of the two vector logical functional units to use: the Full Vector Logical functional unit or the Second Vector Logical functional unit. If the Second Vector Logical unit is enabled (through the Exchange Package), instructions 140 through 145 attempt to issue there first. If the unit is busy, issue is attempted to the Full Vector Logical unit. When both units are busy, the first unit to clear is selected for issue. Instructions will issue to the Full Vector Logical unit first, even though the Second Vector Logical unit is not busy, if another conflict is present for the Second Vector Logical unit (for example, a register reservation).

[†] Not available on all dual-processor systems

NOTE

Since the Second Vector Logical functional unit and the Floating-point Multiply functional units share input and output data paths, they cannot be used simultaneously. When the Second Vector Logical unit is enabled, the two units share the same functional unit Busy signal. Also, because using the Second Vector Logical functional unit also ties up the Floating-point Multiply functional unit, some codes that rely on floating-point products may run slower if the Second Vector Logical functional unit is enabled.

The Second Vector Logical functional unit can be disabled through software by clearing bit 0 of word 3 in the Exchange Package of a user program. When the Second Vector Logical unit is disabled (by clearing the Enable Second Vector Logical bit in the Exchange Package), the functional unit Busy signal for the the unit always appears to be set and causes all 140 through 145 instructions to use the Full Vector Logical unit.

The Second Vector Logical functional unit time is 4 CPs.

Vector Population/Parity functional unit

The Vector Population/Parity functional unit counts the 1 bits in each element of the source V register. The total number of 1 bits is the population count. This population count can be an odd or an even number, as shown by its low-order bit.

Instructions 174*ij*1 (vector population count) and 174*ij*2 (vector population count parity) use the same operation code as the vector reciprocal approximation instruction. Some restrictions for the Reciprocal Approximation functional unit also apply for vector population instructions (see subsection on Reciprocal Approximation). The vector population count instruction delivers the total population count to elements of the destination V register.

The vector population count parity instruction delivers the low-order bit of the count to the destination V register. The Vector Population/Parity functional unit time is 5 CPs.

FLOATING-POINT FUNCTIONAL UNITS

Three floating-point functional units perform floating-point arithmetic for scalar and vector operations. When executing a scalar instruction, operands are obtained from S registers and results are delivered to an S register. When executing most vector instructions, operands are obtained from pairs of V registers or from an S register and a V register. Results are delivered to a V register. An exception is the Reciprocal Approximation unit requiring only one input operand.

Information on floating-point out-of-range conditions is contained in the subsection on Floating-point Arithmetic.

Floating-point Add functional unit

The Floating-point Add functional unit performs addition or subtraction of 64-bit operands in floating-point format and executes instructions 062, 063, and 170 through 173. A result is normalized even when operands are unnormalized. (Normalized floating-point numbers are described in the subsection on Floating-point Arithmetic.) Out-of-range exponents are detected as described in the subsection on Floating-point Arithmetic.

Floating-point Add functional unit time is 6 CPs.

Floating-point Multiply functional unit

The Floating-point Multiply functional unit executes instructions 064 through 067 and 160 through 167. These instructions provide for full- and half-precision multiplication of 64-bit operands in floating-point format and for computing two minus a floating-point product for reciprocal iterations.

The half-precision product is rounded; the full-precision product can be rounded or not rounded.

Input operands are assumed to be normalized. The Floating-point Multiply functional unit delivers a normalized result only if both input operands are normalized.

NOTE

On systems equipped with the Second Vector Logical functional unit, the Floating-point Multiply and Second Vector Logical functional units cannot be used simultaneously since they share input and output data paths. A reservation on one is a reservation on the other.

Out-of-range exponents are detected as described in the subsection on floating-point arithmetic. However, if both operands have zero exponents, the result is considered as an integer product, is not normalized, and is not considered out-of-range. This case provides a fast method of computing a 48-bit integer product, although the operands in this case must be shifted before the multiply operation.

The Floating-point Multiply functional unit time is 7 CPs.

Reciprocal Approximation functional unit

The Reciprocal Approximation functional unit finds the approximate reciprocal of a 64-bit operand in floating-point format. The unit executes instructions 070 and 174*ij*0. Since the Vector Population/Parity functional unit shares some logic with this unit, the *k* designator must be 0 for the reciprocal approximation instruction to be recognized.

The input operand is assumed to be normalized and if so the result is correct. The high-order bit of the coefficient is not tested but is assumed to be a 1. Out-of-range exponents are detected as described under Floating-point Arithmetic.

The Reciprocal Approximation functional unit time is 14 CPs.

ARITHMETIC OPERATIONS

Functional units in a CPU perform either two's complement integer arithmetic or floating-point arithmetic.

INTEGER ARITHMETIC

All integer arithmetic, whether 24 bits or 64 bits, is two's complement and is represented in the registers as illustrated in figure 4-4. The Address Add and Address Multiply functional units perform 24-bit arithmetic. The Scalar Add and the Vector Add functional units perform 64-bit arithmetic.

Multiplication of two scalar (64-bit) integer operands is accomplished by using the floating-point multiply instruction and one of the two methods that follows. The method used depends on the magnitude of the operands and the number of bits to contain the product.

Twos complement integer (24 bits)

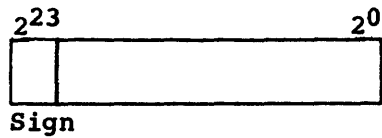

Twos complement integer (64 bits)

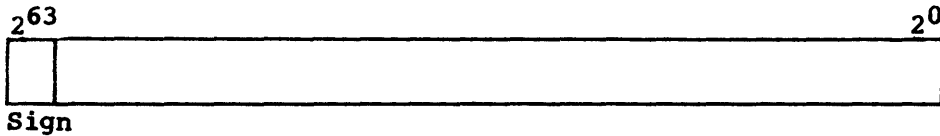

Figure 4-4. Integer data formats

If the operands are nonzero only in the 24 least significant bits, the two integer operands can be multiplied by shifting them each left 24 bits before the multiply operation. (The Floating-point Multiply functional unit recognizes the conditions where both operands have zero exponents as a special case.) The Floating-point Multiply functional unit returns the high-order 48 bits of the product of the coefficients as the coefficient of the result and leaves the exponent field zero. See figure 4-7. If the operand coefficients are generated by other than shifting so the low-order 24 bits would be nonzero, the low-order 48 bits of the product could have been nonzero, and the high-order 48 bits (the return part) could be one larger than expected as a truncation compensation constant is always added during a multiply.

If the operands are greater than 24 bits, multiplication is done by forming multiple partial products and then shifting and adding the partial products.

Division is done by algorithm; the particular algorithm used depends on the number of bits in the quotient. The quickest and most frequently used method is to convert the numbers to floating-point format and then use the floating-point functional units.

FLOATING-POINT ARITHMETIC

Floating-point numbers are represented in a standard format throughout the CPU. This format is a packed representation of a binary coefficient and an exponent (power of two). The coefficient is a 48-bit signed

fraction. The sign of the coefficient is separated from the rest of the coefficient as shown in figure 4-5. Since the coefficient is signed magnitude, it is not complemented for negative values.

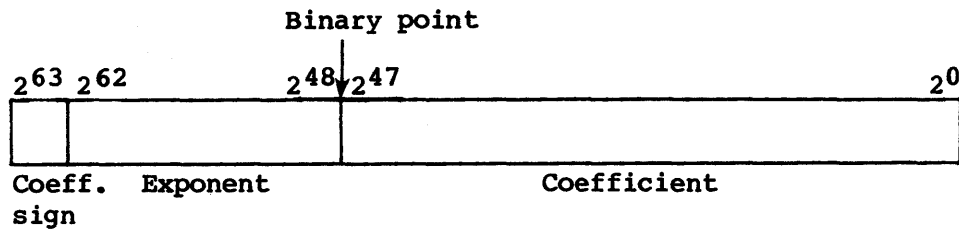

Figure 4-5. Floating-point data format

The exponent portion of the floating-point format is represented as a biased integer in bits 2^{62} through 2^{48} . The bias that is added to the exponents is 40000_8 . The positive range of exponents is 40000_8 through 57777_8 . The negative range of exponents is 37777_8 through 20000_8 . Thus, the unbiased range of exponents is the following (note the negative range is one larger):

$$2^{-20000_8} \text{ through } 2^{+17777_8}$$

In terms of decimal values, the floating-point format of the system allows the accurate expression of numbers to about 15 decimal digits in the approximate decimal range of 10^{-2466} through 10^{+2466} .

A zero value or an underflow result is not biased and is represented as a word of all zeros.

A negative zero is not generated by any floating-point functional unit, except in the case where a negative zero is one operand going into the Floating-point Multiply functional unit.

Normalized floating-point numbers, floating-point range errors, double-precision numbers, and the addition, multiplication, and division algorithms are described in the remainder of this subsection.

Normalized floating-point numbers

A nonzero floating-point number is normalized if the most significant bit of the coefficient is nonzero. This condition implies the coefficient has been shifted as far left as possible and the exponent adjusted accordingly. Therefore, the floating-point number has no leading zeros in the coefficient. The exception is that a normalized floating-point zero is all zeros.

When a floating-point number is created by inserting an exponent of 40060₈ into a 48-bit integer word, the result should be normalized before being used in a floating-point operation. Normalization is accomplished by adding the unnormalized floating-point operand to 0. Since S0 provides a 64-bit zero when used in the S_j field of an instruction, an operand in S_k is normalized using the 062i0_k instruction. S_i, which can be S_k, contains the normalized result.

The 170i0_k instruction normalizes V_k into V_i.

Floating-point range errors

Overflow of the floating-point range is indicated by an exponent value of 60000₈ or greater in packed format. Detection of the overflow condition initiates an interrupt if the Floating-point Mode flag is set in the Mode register and monitor mode is not in effect. The Floating-point Mode flag can be set or cleared by a user mode program.

The Cray Operating System (COS) keeps a bit in a table to indicate the condition of the mode bit. System software manipulates the mode bit and uses the table bit to indicate how the mode should be left for the user. Therefore, the user usually needs to put the appropriate bit in the table if the user changes the mode.

Floating-point range error conditions are detected by the floating-point functional units as described in the following paragraphs.

Floating-point Add functional unit - A floating-point add range error condition is generated for scalar operands when the larger incoming exponent is greater than or equal to 60000₈. This condition sets the Floating-point Error flag with an exponent of 60000₈ being sent to the result register along with the computed coefficient, as in the following example:

60000.4xxxxxxxxxxxxxxxxx	Range error
+57777.4xxxxxxxxxxxxxxxxx	
<u>60000.6xxxxxxxxxxxxxxxxx</u>	Result register

NOTE

If the result of an add or subtract operation is less than the machine minimum, the error is suppressed (even though both operands have exponents greater than or equal to 60000₈) because the machine minimum takes precedence in error detection.

Floating-point Multiply functional unit - Whether or not out-of-range conditions occur, and how they are handled, can be determined using the exponent matrix shown in figure 4-6. The exponent of the result, for any set of exponents, falls into one of seven unique zones. Each zone is described below.

NOTE

If either operand is less than the machine minimum, the error is suppressed (even though the other operand can be out of range) because the operand that is less than the machine minimum takes precedence in error detection.

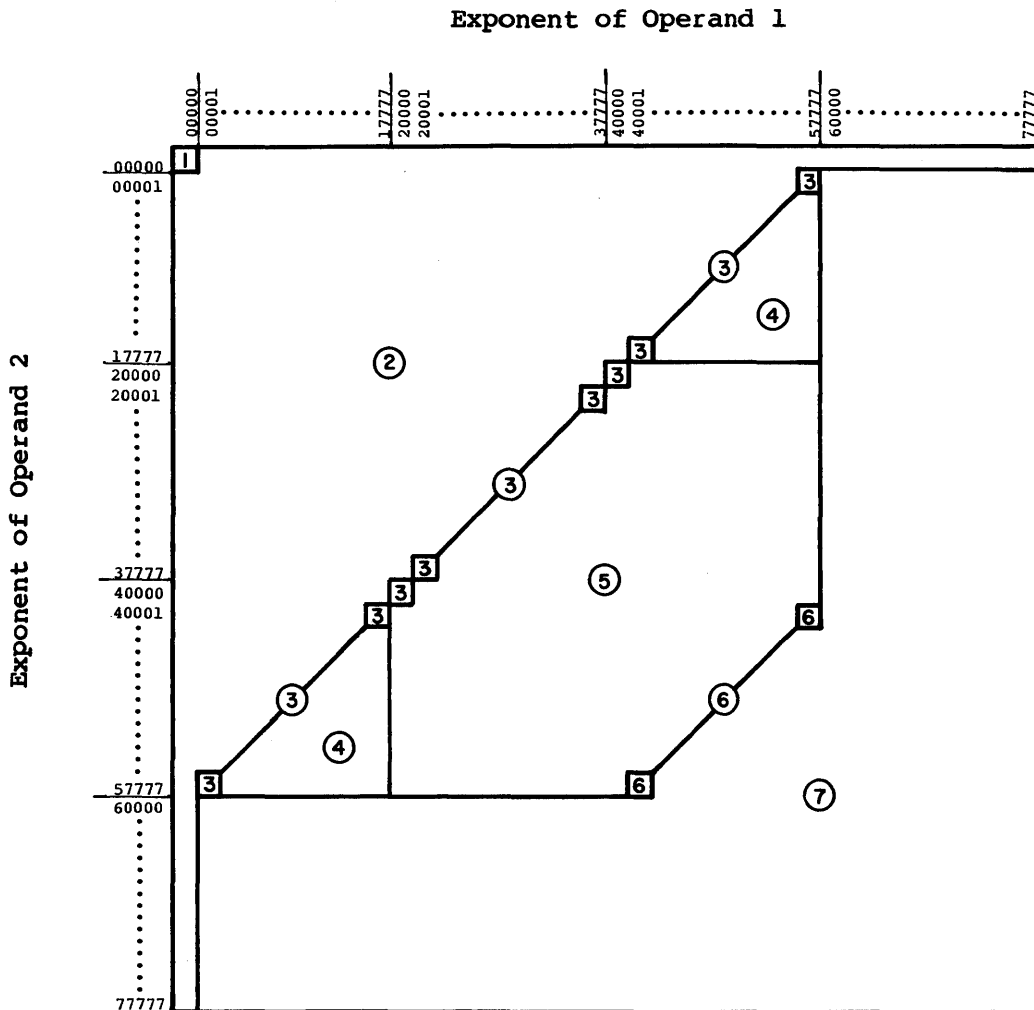

Figure 4-6. Exponent matrix for Floating-point Multiply unit

Zone Description

- 1 Indicates a simple integer multiply; no fault is possible.
- 2 These exponents would result in an underflow condition. It is flagged as such, and the result is set to +0. (Multiply by 0 is in this group.)
- 3 Underflow may occur on this boundary. The final exponent can be 17777_8 or 20000_8 depending on whether a normalized shift is required. If the exponent is 17777_8 and no normalized shift is required, the underflow will not be detected, and the coefficient and exponent will not be zeroed out. Underflow detection is done on the exponent used for an unshifted product coefficient.
- 4 The use of an underflow exponent is allowed if the final result is within the range 20000_8 to 57777_8 .
- 5 This is the normal operand range and normal results are produced.
- 6 Overflow is flagged on this boundary. If a normalized shift is required, the value should be within bounds with a 57777_8 exponent. However, since overflow is detected using the exponent for the unnormalized shift condition (which is 60000_8), a 60000_8 is inserted in the product as the final exponent.
- 7 Within this zone, an overflow fault is flagged and the product exponent is set to 60000_8 .

Out-of-range conditions are tested before normalizing in the Floating-point Multiply functional unit.

As shown above, if both incoming exponents are equal to 0, the operation is treated as an integer multiply. The result is treated normally with no normalization shift of the result allowed. The result is a 48-bit quantity starting with bit 2^{47} . When using this feature, the operands should be considered as 24-bit integers in bits 2^{47} through 2^{24} . In figure 4-7, if operand 1 is 4 and operand 2 is 6, a 48-bit result of 30_8 is produced. Bit 2^{63} obeys the usual rules for multiplying signs and the result is a sign and magnitude integer. Note the form of integers (see figure 4-4) accepted by the integer add and subtract and expected by the software is twos complement not sign and magnitude. Therefore, negative products must be converted.

If bits 2^0 through 2^{23} in operands 1 and 2 of figure 4-7 have any 1 bits, the product might be one (2^0) too large because a truncation compensation constant is added during the multiply process. (The following paragraphs discuss the truncation constant and its use.) The size of the shaded area in operands 1 and 2 (figure 4-7) does not need to

be the same for both operands. To get a correct product, the only requirement is that the sum of the number of bits in the shaded area is 48 bits or more. If the sum is more than 48 bits, the binary point in the product is the number of places to the left that the sum is in excess of 48 (that is, assuming the operand binary points are at the left boundary of the shaded areas).

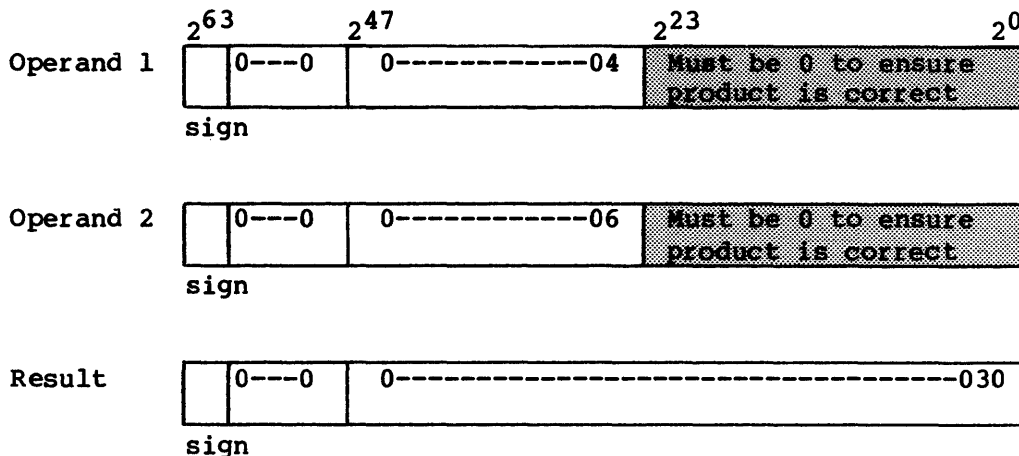

Figure 4-7. Integer multiply in Floating-point Multiply functional unit

Floating-point Reciprocal Approximation functional unit - For the Floating-point Reciprocal Approximation functional unit, an incoming operand with an exponent less than or equal to 20001_8 or greater than or equal to 60000_8 causes a floating-point range error. The error flag is set and an exponent of 60000_8 and the computed coefficient are sent to the result register.

Double-precision numbers

The CPU does not provide special hardware for performing double- or multiple-precision operations. Double-precision computations with 95-bit accuracy are available through software routines provided by Cray Research, Inc.

Addition algorithm

Floating-point addition or subtraction is performed in a 49-bit register (figure 4-8). Trial subtraction of the exponents selects the operand to be shifted down for aligning the operands. The larger exponent operand carries the sign. The coefficient of the number with the smaller exponent is shifted right to align with the coefficient of the number with the larger exponent. Bits shifted out of the register are lost; no

roundup takes place. If the sum carries into the high-order bit, the low-order bit is discarded and an appropriate exponent adjustment is made. All results are normalized and if the result is less than the machine minimum, the error is suppressed.

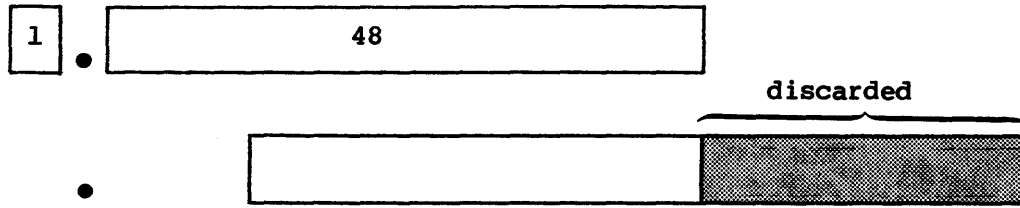

Figure 4-8. 49-bit floating-point addition

The Floating-point Add functional unit normalizes any floating-point number within the format of the mainframe's floating-point number system. The functional unit right shifts 1 or left shifts up to 48 per result to normalize the result.

One zero operand and one valid operand can be sent to the Floating-point Add functional unit, and the valid operand is sent through the unit normalized. Concurrently, the functional unit checks for overflow and/or underflow; underflow results are not flagged as errors.

Multiplication algorithm

The Floating-point Multiply functional unit has the two 48-bit coefficients as input into a multiply pyramid (see figure 4-9). If the coefficients are both normalized, then a full product is either 95 bits or 96 bits, depending on the value of the coefficients. A 96-bit product is normalized as generated. A 95-bit product requires a left shift of one to generate the final coefficient. If the shift is done, the final exponent is reduced by one to reflect the shift.

The following discussion and the power of two designators used assumes that the product generated is in its final form; that is, no shift was required.

On the system, the pyramid truncates part of the low-order bits of the 96-bit product. To adjust for this truncation, a constant is unconditionally added above the truncation. The average value of this truncation is 9.25×2^{-56} , which was determined by adding all carries produced by all possible combinations that could be truncated and dividing the sum by the number of possible combinations. Nine carries are injected at the 2^{-56} position to compensate for the truncated bits.

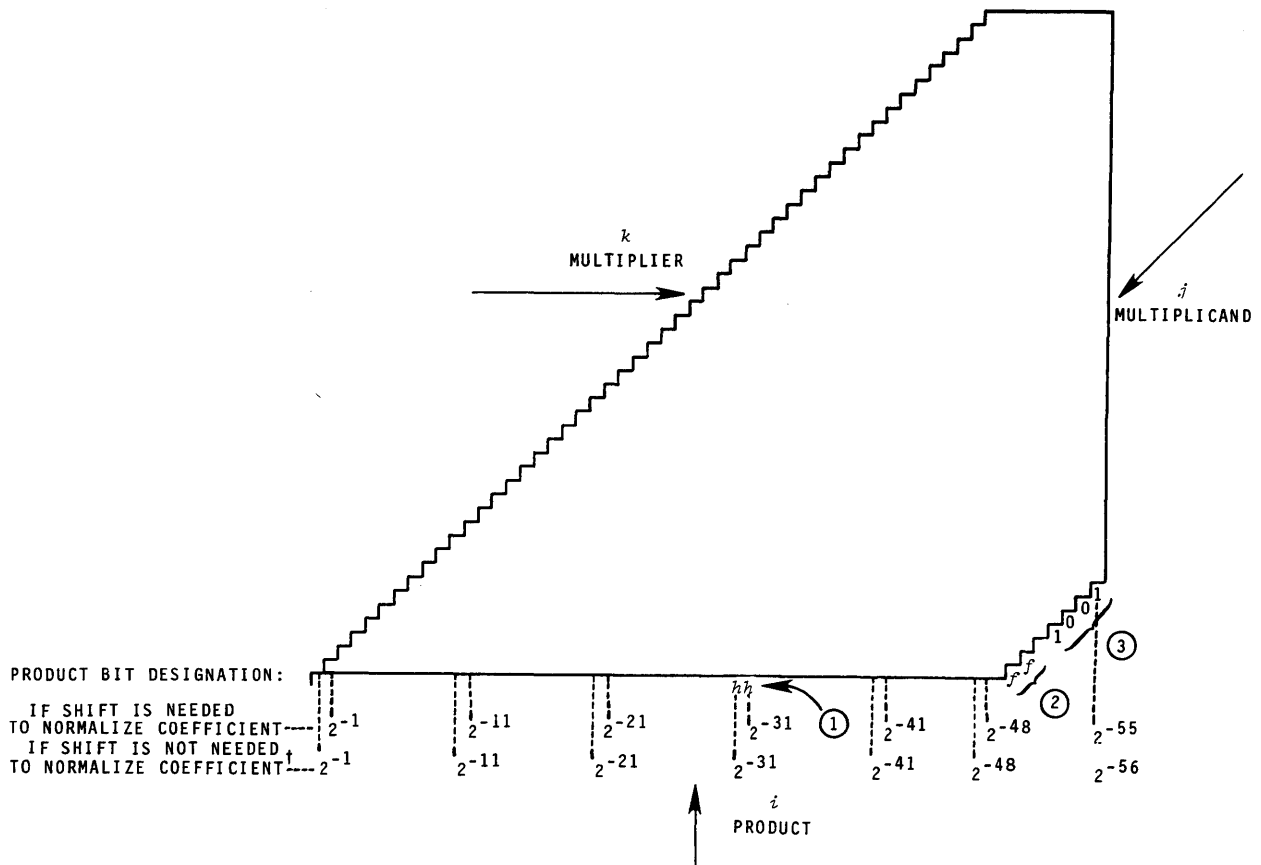

- ① $hh = 11_2$ for half-precision round, 00_2 for full-precision rounded or full-precision unrounded multiply
- ② $ff = 11_2$ for full-precision round, 00_2 for half-precision rounded or full-precision unrounded multiply
- ③ Truncation compensation constant, 1001_2 used for all multiplies

Figure 4-9. Floating-point multiply partial-product sums pyramid

† Bit designations are used in the explanation of the Floating-point Multiply functional unit operation.

The effect of the truncation without compensation is at most a result coefficient one smaller than expected. With compensation, the results range from one too large to one too small in the 2^{-48} bit position with approximately 99 percent of the values having zero deviation from what would have been generated had a full 96-bit pyramid been present. The multiplication is commutative; that is, A times B equals B times A.

Rounding is optional where truncation compensation is not. The rounding method used adds a constant so that it is 50 percent high ($.25 \times 2^{-48}$; high) 38 percent of the time and 25 percent low ($.125 \times 2^{-48}$; low) 62 percent of the time resulting in near zero average rounding error. In a full-precision rounded multiply, 2 round bits are entered into the pyramid at bit position 2^{-50} and 2^{-51} and allowed to propagate up the pyramid.

For a half-precision multiply, round bits are entered into the pyramid at bit positions 2^{-32} and 2^{-31} . A carry resulting from this entry is allowed to propagate up and the 29 most significant bits of the normalized result are transmitted back.

The variation due to this truncation and rounding are in the range:

$$\begin{aligned} & -0.23 \times 2^{-48} \text{ to } +0.57 \times 2^{-48} \\ \text{or} & \quad -8.17 \times 10^{-16} \text{ to } +20.25 \times 10^{-16}. \end{aligned}$$

With a full 96-bit pyramid and rounding equal to one-half the least significant bit, the variation would be expected to be:

$$-0.5 \times 2^{-48} \text{ to } +0.5 \times 2^{-48}$$

Division algorithm

The system performs floating-point division through reciprocal approximation, facilitating hardware implementation of a fully segmented functional unit. Because of this segmentation, operands enter the reciprocal unit during each CP. In vector mode, results are produced at a 1-CP rate and are used in other vector operations during chaining because all functional units in the system have the same result rate. The reciprocal approximation is based on Newton's method.

Newton's method - The division algorithm is an application of Newton's method for approximating the real roots of an arbitrary equation $F(x) = 0$, for which $F(x)$ must be twice differentiable with a continuous second derivative. The method requires making an initial approximation (guess), x_0 , sufficiently close to the true root, x_t , being sought (see figure 4-10). For a better approximation, a tangent line is drawn to the graph of $y = F(x)$ at the point $(x_0, F(x_0))$. The X intercept of this tangent line is the better approximation x_1 . This can be repeated using x_1 to find x_2 , etc.

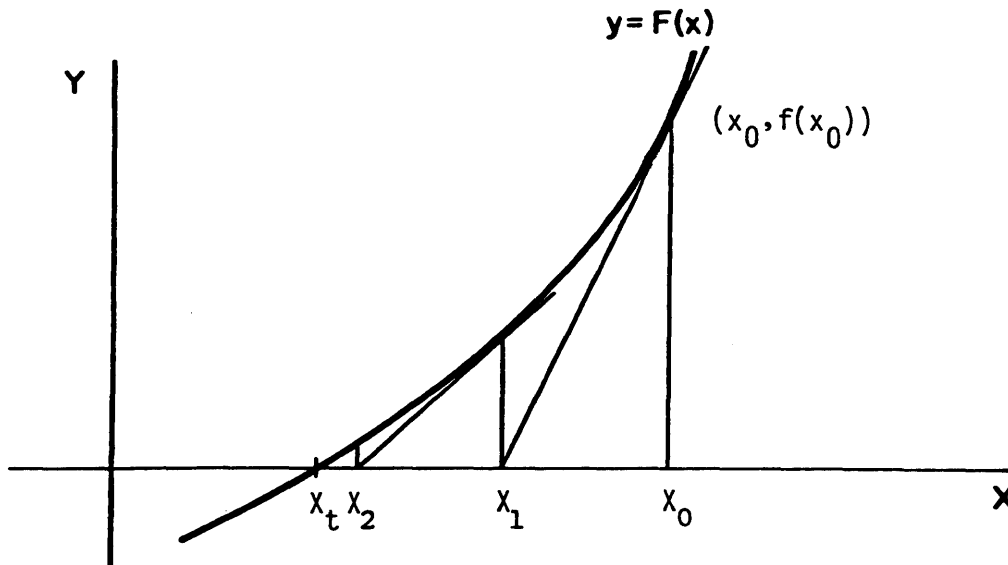

Figure 4-10. Newton's method

Derivation of the division algorithm

A definition for the derivative $F'(x)$ of a function $F(x)$ at point x_t is

$$F'(x_t) = \lim_{x \rightarrow x_t} \frac{F(x) - F(x_t)}{x - x_t}$$

if this limit exists. If the limit does not exist, $F(x)$ is not differentiable at the point t .

For any point x_i near to x_t ,

$$F'(x_t) \approx \frac{F(x_i) - F(x_t)}{x_i - x_t} \text{ where } \approx \text{ means "approximately equal to".}$$

This approximation improves as x_i approaches x_t . Let x_i stand for an approximate solution and let x_t stand for the true answer being sought. The exact answer is then the value of x that makes $F(x)$ equal 0. This is the case when $x=x_t$, therefore $F(x_t)$ in the equation above can be replaced by 0, giving the following approximation:

$$F'(x_t) \approx \frac{F(x_i)}{x_i - x_t} \qquad \text{Approximation (1)}$$

Notice that $x_t - x_i$ is the correction applied to an approximate answer, x_i , to give the right answer since $x_i + (x_t - x_i)$ equals x_t . Solving approximation (1) for $(x_t - x_i)$ gives:

$$x_t - x_i = \text{correction} \approx - \frac{F(x_i)}{F'(x_t)},$$

that is, $-\frac{F(x_i)}{F'(x_t)}$ is the approximate correction.

If this quantity is substituted into the approximation, then:

$$x_t \approx (x_i + \text{approximate correction}) = x_{i+1}.$$

This gives, the following equation:

$$x_{i+1} = x_i - \frac{F(x_i)}{F'(x_i)}, \quad \text{Equation (1)}$$

where x_{i+1} is a better approximation than x_i to the true value, x_t , being sought. The exact answer is generally not obtained at once because the correction term is not generally exact. However, the operation is repeated until the answer becomes sufficiently close for practical use.

To make use of Newton's method to find the reciprocal of a number B, simply use $F(x) = (1/x - B)$.

First calculating $F'(x)$:

where $F'(x) = \left(\frac{1}{x} - B\right)' = \left(\frac{-1}{x^2}\right)$. thus for any point $x_1 \neq 0$,

$$F'(x_1) = -\frac{1}{x_1^2}. \quad \text{Choosing for } x, \text{ a value near } \frac{1}{B}$$

and applying equation (1),

$$x_2 = x_1 - \frac{\frac{1}{x_1} - B}{-\frac{1}{x_1^2}},$$

$$x_2 = x_1 + x_1^2 \left(\frac{1}{x_1} - B\right),$$

$$x_2 = x_1 + x_1 - x_1^2 B,$$

$$x_2 = 2x_1 - x_1^2 B = x_1(2 - x_1 B).$$

On the system, x_1 times the quantity in parentheses is performed by a floating-point multiply. $2 - x_1 B$ is performed by the reciprocal

approximation instruction. x_1 is the x near $1/B$ and is formed by the half-precision reciprocal approximation instruction.

This approximation technique using Newton's method is implemented in the system. A hardware table look up provides an initial guess, x_0 , to start the process.

$x_0(2 - x_0B)$	1st approximation, I1	} Done in reciprocal unit
$x_1(2 - x_1B)$	2nd approximation, I2	
$x_2(2 - x_2B)$	3rd approximation, I3	
$x_3(2 - x_3B)$	4th approximation	Done with software

The system's Reciprocal Approximation functional unit performs three iterations: I1, I2 and I3. I1 is accurate to 8 bits and is found after a table look-up to choose the initial guess, x_0 . I2 is the second iteration and is accurate to 16 bits. I3 is the final (third) iteration answer of the Reciprocal Approximation functional unit, and its result is accurate to 30 bits.

A fourth iteration uses a special instruction within the Floating-point Multiply functional unit to calculate the correction term. This iteration is used to increase accuracy of the reciprocal unit's answer to full precision. A fifth iteration should not be done.

The division algorithm that computes $S1/S2$ to full-precision requires the following operations:

$S3 = 1/S2$	Performed by the Reciprocal Approximation functional unit
$S4 = (2 - (S3 * S2))$	Performed by the Floating-point Multiply functional unit in iteration mode
$S5 = S4 * S3$	Performed by the Floating-point Multiply functional unit using full-precision. S5 now equals $1/S2$ to 48-bit accuracy.
$S6 = S5 * S1$	Performed by the Floating-point Multiply functional unit using full-precision rounded

The reciprocal approximation at step 1 is correct to 30 bits. An additional Newton iteration (fourth iteration) at operations 2 and 3 increases this accuracy to 48 bits. This iteration answer is applied as an operand in a full-precision rounded multiply operation to obtain the quotient accurate to 48 bits. Additional iterations should not be attempted since erroneous results are possible.

CAUTION

The reciprocal iteration is designed for use once with each half-precision reciprocal generated. If the fourth iteration (the programmed iteration) results in an exact reciprocal or if an exact reciprocal is generated by some other method, performing another iteration results in an incorrect final reciprocal.

Where 29 bits of accuracy are sufficient, the reciprocal approximation instruction is used with the half-precision multiply to produce a half-precision quotient in only two operations.

$S3 = 1/S2$ Performed by the Reciprocal Approximation functional unit

$S6 = S1 * S3$ Performed by the Floating-point Multiply functional unit in half-precision

The 19 low-order bits of the half-precision results are returned as zeros with a rounding applied to the low-order bit of the 29-bit result.

Another method of computing divisions is as follows:

$S3 = 1/S2$ Performed by the Reciprocal Approximation functional unit

$S5 = S1 * S3$ Performed by the Floating-point Multiply functional unit

$S4 = (2 - (S3 * S2))$ Performed by the Floating-point Multiply functional unit

$S6 = S4 * S5$ Performed by the Floating-point Multiply functional unit

A scalar quotient is computed in 29 CPs since operations 2 and 3 issue in successive CPs. With this method the correction to reach a full-precision reciprocal is applied after the numerator is multiplied times the half-precision reciprocal rather than before.

A vector quotient using this procedure requires less than four vector times since operations 1 and 2 are chained together. This overlaps one of the multiply operations. (A vector time is 1 CP for each element in the vector.)

CAUTION

The coefficient of the reciprocal produced by the alternate method can be as much as 2×2^{-48} different from the first method described for generating full-precision reciprocals. This difference can occur because one method can round up as much as twice while the other method may not round at all. One round can occur while the correction is generated and the second round can occur when producing the final quotient.

Therefore, if the reciprocals are to be compared, the same method should be used each time the reciprocals are generated. Cray FORTRAN (CFT) uses a consistent method and ensures the reciprocals of numbers are always the same.

For example, two 64-element vectors are divided in $3 * 64$ CPs plus overhead. (The overhead associated with the functional units for this case is 38 CPs).

LOGICAL OPERATIONS

Scalar and vector logical units perform bit-by-bit manipulation of 64-bit quantities. Operations provide for forming logical products, differences, sums, and merges.

A logical product is the AND function:

Operand 1	1 0 1 0
Operand 2	<u>1 1 0 0</u>
Result	1 0 0 0

An operation similar to the AND function produces the following results:

Operand 1	1 0 1 0
Operand 2	<u>1 1 0 0</u>
Result	0 1 0 0

The logical product (AND) operation is used for masking operations where the ones specify the bits to be saved. In this variant of the AND function, the zeros specify the bits to be saved (Operand 1 is the mask).

A logical sum is the inclusive OR function:

Operand 1	1 0 1 0
Operand 2	<u>1 1 0 0</u>
Result	1 1 1 0

A logical difference is the exclusive OR function:

Operand 1	1 0 1 0
Operand 2	<u>1 1 0 0</u>
Result	0 1 1 0

A logical equivalence is the exclusive NOR function:

Operand 1	1 0 1 0
Operand 2	<u>1 1 0 0</u>
Result	1 0 0 1

The merge uses two operands and a mask to produce results as follows:

Operand 1	1 0 1 0 1 0 1 0
Operand 2	1 1 0 0 1 1 0 0
Mask	<u>1 1 1 1 0 0 0 0</u>
Result	1 0 1 0 1 1 0 0

The bits of operand 1 pass where the mask bit is 1. The bits of operand 2 pass where the mask bit is 0.

INSTRUCTION FORMAT

Each instruction used in the computer is either a 1-parcel (16-bit) instruction or a 2-parcel (32-bit) instruction. Instructions are packed four parcels per word. Parcels in a word are numbered 0 through 3 from left to right and any parcel position can be addressed in branch instructions. A 2-parcel instruction begins in any parcel of a word and can span a word boundary. For example, a 2-parcel instruction beginning in the fourth parcel of a word ends in the first parcel of the next word. No padding to word boundaries is required. Figure 5-1 illustrates the general form of instructions.

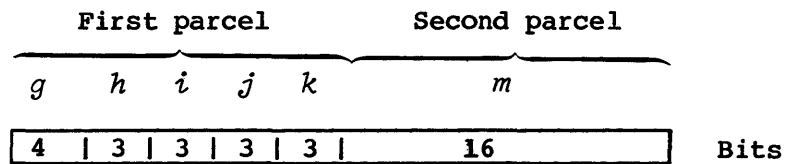

Figure 5-1. General form for instructions

Four variations of this general format use the fields differently; two forms are 1-parcel formats and two are 2-parcel formats. The formats of these four variations are described below.

1-PARCEL INSTRUCTION FORMAT WITH DISCRETE *j* AND *k* FIELDS

The most common of the 1-parcel instruction formats uses the *i*, *j*, and *k* fields as individual designators for operand and result registers (see figure 5-2). The *g* and *h* fields define the operation code. The *i* field designates a result register and the *j* and *k* fields designate operand registers. Some instructions ignore one or more of the *i*, *j*, and *k* fields. The following types of instructions use this format.

- Arithmetic
- Logical
- Double shift
- Floating-point constant

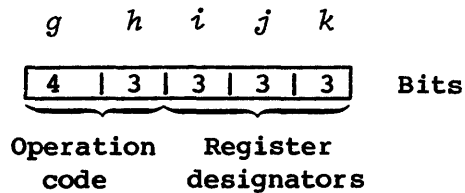

Figure 5-2. 1-parcel instruction format with discrete j and k fields

1-PARCEL INSTRUCTION FORMAT WITH COMBINED j AND k FIELDS

Some 1-parcel instructions use the j and k fields as a combined 6-bit field (see figure 5-3). The g and h fields contain the operation code, and the i field is generally a destination register identifier. The combined j and k fields generally contain a constant or a B or T register designator. The branch instruction 005 and the following types of instructions use the 1-parcel instruction format with combined j and k fields.

- Constant
- B and T register block memory transfer
- B and T register data transfer
- Single shift
- Mask

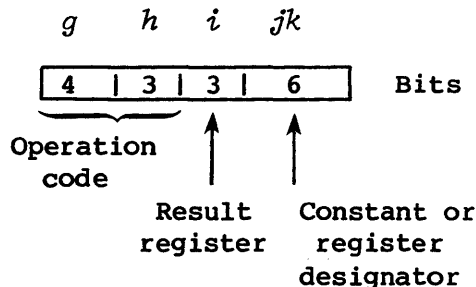

Figure 5-3. 1-parcel instruction format with combined j and k fields

2-PARCEL INSTRUCTION FORMAT WITH COMBINED j , k , AND m FIELDS

The instruction type for a 22-bit immediate constant uses the combined j , k , and m fields to hold the constant. The 7-bit gh field contains an operation code, and the 3-bit i field designates a result register. The instruction type using this format transfers the 22-bit jkm constant to an A or S register.

The instruction type used for scalar memory transfers also requires a 22-bit *jkm* field for an address displacement. This instruction type uses the 4-bit *g* field for an operation code, the 3-bit *h* field to designate an address index register, and the 3-bit *i* field to designate a source or result register. (See subsection on Special Register Values.)

Figure 5-4 shows the two general applications for the 2-parcel instruction format with combined *j*, *k*, and *m* fields.

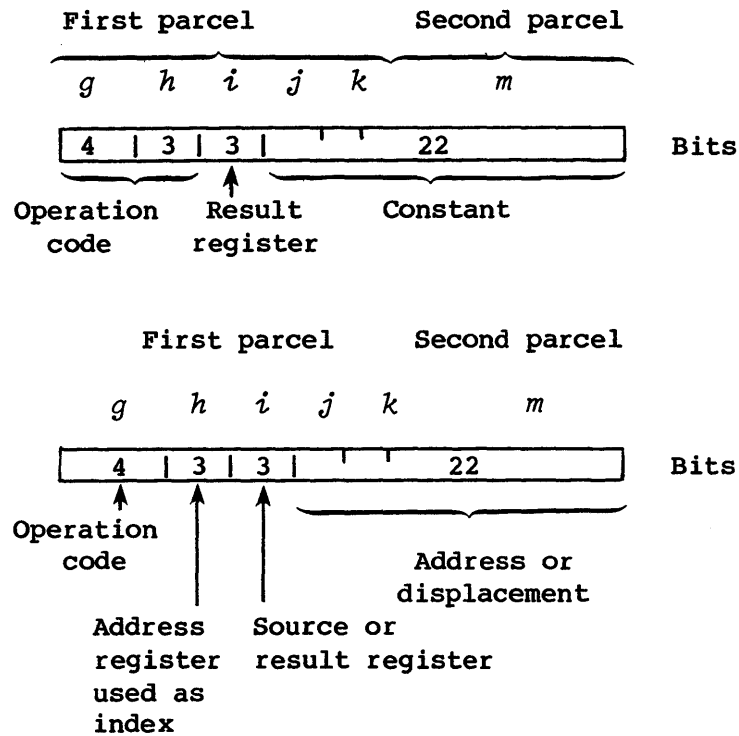

Figure 5-4. 2-parcel instruction format with combined *j*, *k*, and *m* fields

2-PARCEL INSTRUCTION FORMAT WITH COMBINED *i*, *j*, *k*, AND *m* FIELDS

The 2-parcel instruction type for a branch (figure 5-5) uses the combined *i*, *j*, *k*, and *m* fields to contain the 24-bit address that allows branching to an instruction parcel. A 7-bit operation code (*gh*) is followed by an *ijkm* field. The high-order bit of the *i* field is clear.

The 2 parcel instruction type for a 24-bit immediate constant (figure 5-6) uses the combined *i*, *j*, *k*, and *m* fields to hold the constant. This instruction type uses the 4-bit *g* field for an operation code and the 3-bit *h* field to designate the result address register. The high-order bit of the *i* field is set.

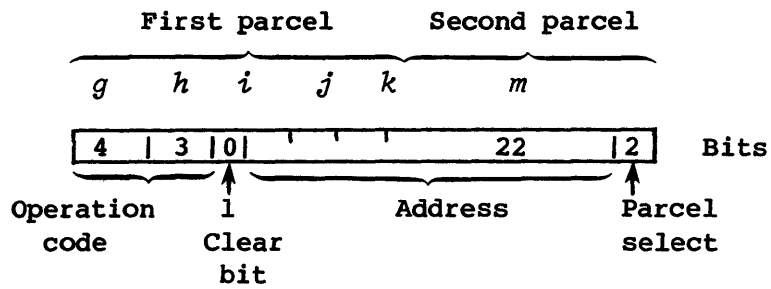

Figure 5-5. 2-parcel instruction format for a branch with combined *i*, *j*, *k*, and *m* fields

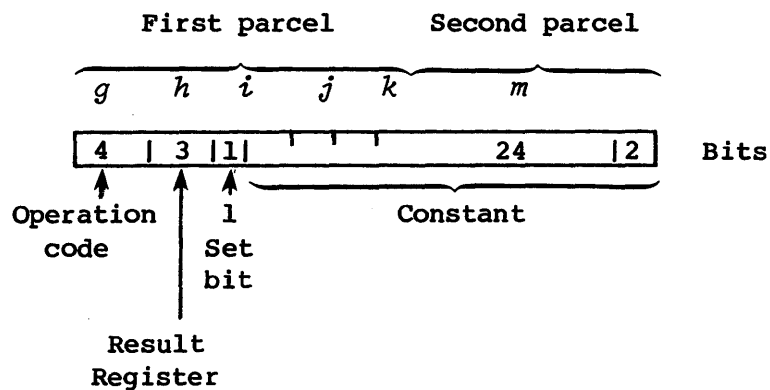

Figure 5-6. 2-parcel instruction format for a 24-bit immediate constant with combined *i*, *j*, *k*, and *m* fields

SPECIAL REGISTER VALUES

If the S0 and A0 registers are referenced in the *j* or *k* fields of an instruction, the contents of the respective register are not used; instead, a special operand is generated. The special value is available regardless of existing A0 or S0 reservations (and in this case are not checked). This use does not alter the actual value of the S0 or A0 register. If S0 or A0 is used in the *i* field as the operand, the actual value of the register is provided. The table below shows the special register values.



Field	Operand value
$Ah, h=0$	0
$Ai, i=0$	(A0)
$Aj, j=0$	0
$Ak, k=0$	1
$Si, i=0$	(S0)
$Sj, j=0$	0
$Sk, k=0$	2^{63}

INSTRUCTION ISSUE

Instructions are read one parcel at a time from the instruction buffers and delivered to the Next Instruction Parcel (NIP) register. The instruction is then passed to the Current Instruction Parcel (CIP) register when the previous instruction issues. An instruction in the CIP register issues when conditions in the functional unit and registers are such that functions required for execution can be performed without conflicting with a previously issued instruction. Instruction parcels can issue out of the CIP register at a maximum rate of one per clock period.

Execution times (the time from issue to delivery of data to the destination operating registers) are fixed for instructions 000 through 077, except those that reference memory (instructions 000, 004, branch instructions 005 through 017, and block transfer instructions 034 through 037). Scalar memory instructions 100 through 137 complete in variable lengths of time. Vector operation instructions 140 through 177 complete in a fixed time if the instructions are not chained to memory fetches.

Execution times can be affected by instruction 0034 jk , which tests and sets the semaphore designated by jk . If the semaphore is set, instruction issue is held until the other CPU clears that semaphore. If the semaphore is clear, the instruction issues and sets the semaphore. If all CPUs in a cluster are holding issue on a test and set, a flag is set in the Exchange Package (if not in monitor mode) and an exchange occurs. If an interrupt occurs while a test and set instruction is holding in the CIP register, a flag is set in the Exchange Package, CIP and NIP registers clear, and an exchange occurs with the P register pointing to the test and set instruction.

Entry to the NIP register is blocked for the second parcel of a 2-parcel instruction, leaving NIP blanked. Instead, the parcel is delivered to the Lower Instruction Parcel (LIP) register. The zeros in NIP (the pseudo second parcel) are transferred to CIP and issued as a do-nothing instruction.

When special register values (A0 or S0) are selected by an instruction for A_h , A_j , A_k , S_j , or S_k , the normal "hold issue until operand ready" conditions do not apply. These values are always immediately available.

INSTRUCTION DESCRIPTIONS

This section contains detailed information about individual instructions or groups of related instructions. Each instruction begins with boxed information consisting of the Cray Assembly Language (CAL) syntax format, a brief description of each instruction, and the octal code sequence defined by the gh fields. The appearance of an m in a format designates an instruction consisting of two parcels.

Following the boxed information is a more detailed description of the instruction or instructions, including a list of hold issue conditions, execution time, and special cases. Hold issue conditions refer to those conditions delaying issue of an instruction until conditions are met.

Instruction issue time assumes that if an instruction issues at clock period n (CP n), the next instruction issues at CP $n + \text{issue time}^\dagger$ if its own issue conditions have been met.

The following special characters can appear in the operand field description of symbolic machine instructions and are used by the assembler in determining the operation to be performed.

- + Arithmetic sum of adjoining registers
- Arithmetic difference of adjoining registers
- * Arithmetic product of adjoining registers
- / Division or reciprocal
- # Use ones complement
- > Shift value or form mask from left to right
- < Shift value or form mask from right to left
- & Logical product of adjoining registers
- ! Logical sum of adjoining registers
- \ Logical difference of adjoining registers

[†] Previous instruction issued

In some instructions, register designators are prefixed by the following letters, which have special meaning to the assembler.

- F Floating-point operation
- H Half-precision operation
- R Rounded operation
- I Reciprocal iteration
- P Population count
- Q Population count parity
- Z Leading zero count

INSTRUCTION 000

CAL Syntax	Description	Octal Code
ERR	Error exit	000000

Instruction 000 is treated as an error condition and an exchange sequence occurs. Content of the instruction buffers is voided by the exchange sequence. Instruction 000 halts execution of an incorrectly coded program branching into an unused area of memory (if memory was backgrounded with zeros) or into a data area (if the data is positive integers, right-justified ASCII, or floating-point zero). If monitor mode is not in effect, the Error Exit flag in the F register is set. All instructions issued before this instruction are run to completion. When results of previously issued instructions arrive at the operating registers, an exchange occurs to the Exchange Package designated by contents of the XA register. The program address stored during the exchange on the terminating exchange sequence is the contents of the P register advanced by one count (that is, the address of the instruction following the error exit instruction).

HOLD ISSUE CONDITIONS: Any A, S, or V register reserved

EXECUTION TIME: Instruction issue, 40 CPs; this time includes an exchange sequence (24 CPs) and a fetch operation (16 CPs).

SPECIAL CASES: None

INSTRUCTIONS 0010 - 0013

CAL Syntax	Description	Octal Code
CA, A_j A_k	Set the Current Address (CA) register for the channel indicated by (A_j) to (A_k) and activate the channel.	0010 j k
CL, A_j A_k	Set the Limit Address (CL) register for the channel indicated by (A_j) to (A_k).	0011 j k
CI, A_j	Clear the interrupt flag and error flag for the channel indicated by (A_j); clear device master-clear (output channel).	0012 j 0
MC, A_j	Clear the interrupt flag and error flag for the channel indicated by (A_j); set device master-clear (output channel); clear device ready-held (input channel).	0012 j 1
XA A_j	Enter the XA register with (A_j).	0013 j 0

Instructions 0010 through 0013 are privileged to monitor mode and provide operations useful to the operating system. Functions are selected through the i designator. Instructions are treated as pass instructions if the monitor mode bit is not set.

When the i designator is 0, 1, or 2, the instruction controls operation of the I/O channels. Each channel has two registers directing the channel activity. The CA register for a channel contains the address of the current channel word. The CL register specifies the limit address. In programming the channel, the CL register is initialized first and then CA sets, activating the channel. As transfer continues, CA is incremented toward CL. When (CA) is equal to (CL), transfer is complete for words at initial (CA) through (CL)-1. When the j designator is 0 or when the 4 low-order bits of A_j are less than 7_8 , the functions are executed as pass instructions. Valid channel numbers are 7-17 $_8$. When the k designator is 0, CA or CL is set to 1.

When the i designator is 3, the instruction transmits bits 2^{11} through 2^4 of (A_j) to the XA register. When the j designator is 0, the XA register is cleared.

Instruction 0012 j 0 is used to clear the device Master Clear. For instruction 0012, if the k designator is 1 for an output channel, the master clear is set; if the k designator is 1 for an input channel, the ready flag is cleared.

INSTRUCTIONS 0010 - 0013 (continued)

HOLD ISSUE CONDITIONS: For instructions 0010 and 0011, A_j or A_k reserved (except A0)

For instructions 0012 or 0013, A_j reserved (except A0)

EXECUTION TIME: Instruction issue, 1 CP

SPECIAL CASES: If the program is not in monitor mode, the instruction becomes a no-op although all hold issue conditions remain effective.

For instructions 0010, 0011, and 0012:

If $j=0$, the instruction is a no-op.

If $k=0$, CA or CL is set to 1.

If 4 low-order bits of (A_j) are less than 10_8 , the instruction is a no-op, (that is, 20 through 27 are invalid, 30 through 37 are valid, 40 through 47 are invalid, 50 through 57 are valid, etc.).

If $k=0$, CA or CL is set to 1.

For instruction 0012:

The correct priority interrupting channel number cannot be read (through instruction 033) until 2 CPs after issue of instruction 0012.

For instruction 0013:

If $j=0$, XA register is cleared.

NOTE

Because there is no hardware interlock between CPUs, it is possible to have both CPUs issuing these instructions at the same time; however, undetermined results will occur.

Software must ensure only one CPU is servicing I/O at a time while in monitor mode.

INSTRUCTION 0014

CAL Syntax	Description	Octal Code
RT S_j	Enter the Real-time Clock register with (S_j)	0014 j 0
IP 1	Set interprocessor interrupt request of other processor	001401
IP 0	Clear received interprocessor interrupt request from other processors	001402
CLN 0	Cluster number = 0	001403
CLN 1	Cluster number = 1	001413
CLN 2	Cluster number = 2	001423
CLN 3	Cluster number = 3	001433
PCI S_j	Enter Interrupt Interval (II) register with (S_j)	0014 j 4
CCI	Clear the programmable clock interrupt request	001405
ECI	Enable programmable clock interrupt request	001406
DCI	Disable programmable clock interrupt request	001407

Instruction 0014 performs specialized functions for managing the real-time and programmable clocks and handles interprocessor interrupt requests and cluster number operations. Instruction 0014 is privileged to monitor mode and is treated as a pass instruction if the monitor mode bit is not set.

When the k designator is 0, the instruction loads the contents of the S_j register into the RTC register. When the j designator is 0 or (S_j)=0, the RTC register is cleared.

When the k designator is 1, the instruction sets the internal CPU interrupt request in the other CPU. If the other CPU is not in monitor mode, the Interrupt from Internal CPU (ICP) flag sets in the F register causing an interrupt. The request remains until cleared by the receiving CPU issuing instruction 001402.

When the k designator is 2, the instruction clears the internal CPU interrupt request set by the other CPU.

INSTRUCTION 0014 (continued)

When the k designator is 3, the instruction sets the cluster number to j to make the following cluster selections:

CLN = 0 No cluster; all shared register and semaphore operations are no-ops, (except SB, ST, or SM register reads, which return a 0 value to A_i or S_i).

CLN = 1 Cluster 1

CLN = 2 Cluster 2

CLN = 3 Cluster 3

Clusters 1, 2, and 3 each have a separate set of SM, SB, and ST registers.

When the k designator is 4, the instruction loads the low-order 32 bits from the S_j register into both the II register and the ICD counter. When the j designator is 0 or $(S_j)=0$, II and ICD are cleared.

When the k designator is 5, the instruction clears the programmable clock interrupt request if the request is previously set by ICD counting down to 0.

When the k designator is 6, the instruction enables repeated programmable clock interrupt requests at a repetition rate determined by the value stored in the II register.

When the k designator is 7, the instruction disables repeated programmable clock interrupt requests until an instruction 001406 is executed to enable the requests.

HOLD ISSUE CONDITIONS: S_j reserved (except S_0)

For instruction 0014 j 3, hold issue 2 CPs

EXECUTION TIME: Instruction issue, 1 CP

SPECIAL CASES: If the program is not in monitor mode, these instructions become no-ops but all hold issue conditions remain effective.

For instructions 0014 j 0 and 0014 j 4, if $j=0$, $(S_j)=0$.

For instruction 0014 j 0, the value is entered into the RTC register 4 CPs after instruction 0014 j 0 issues.

INSTRUCTION 0015

CAL Syntax	Description	Octal Code
†	Select performance monitor	0015j0
†	Set maintenance read mode	001501
†	Load diagnostic check byte with S1	001511
†	Set maintenance write mode 1	001521
†	Set maintenance write mode 2	001531

These instructions are all privileged to monitor mode.

Instruction 0015j0 selects one of four groups of hardware related events to be monitored by the performance counters. See Appendix C for a description of how performance monitoring is accomplished.

Instructions 001501 through 001531 are used to check the operation of the modules concerned with SECDED and to verify error detection and correction. The maintenance mode switch on the mainframe's control panel must be switched on during execution of these instructions or they become no-ops. See Appendix D for a description of SECDED maintenance mode functions.

Instructions 001501 and 001521 are used to verify check bit memory storage. Instruction 001501 allows the 8 check bits for SECDED to replace certain data bit positions in any subsequent memory read for the CPU path (including fetch and I/O). Instruction 001521 allows certain write data bits to replace the 8 check bits for SECDED for any subsequent CPU write to memory.

Instructions 001511 and 001531 are used to verify error detection and correction. Instruction 001511 loads a diagnostic check byte with the high-order 8 bits of S1. Instruction 001531 enables a diagnostic check byte to replace the 8 check bits for SECDED being written into memory for any subsequent write to memory.

† Not supported at present time

INSTRUCTION 0020

CAL Syntax	Description	Octal Code
VL Ak	Transmit (Ak) to VL register	00200 k
VL 1^{\dagger}	Transmit 1 to VL register	002000

Instruction 00200 k enters the VL register with a value determined by the contents of Ak . The low-order 6 bits of (Ak) are entered into the VL register. The 7th bit of VL is set if the 6 low-order bits of (Ak)=0.

For example, if (Ak)=0 or a multiple of 100 $_g$, then VL=100 $_g$. The content of VL is always between 1 and 100 $_g$.

Instruction 002000 transmits the value of 1 to the VL register.

HOLD ISSUE CONDITIONS: Ak reserved (except A0)

EXECUTION TIME: Instruction issue, 1 CP
VL register ready, 1 CP

SPECIAL CASES: Maximum vector length is 64.
(Ak)=1 if $k=0$.
(VL)=100 $_g$ if $k \neq 0$ and (Ak)=0 or a multiple of 100 $_g$.

\dagger Special CAL syntax

INSTRUCTIONS 0021 - 0027

CAL Syntax	Description	Octal Code
EFI	Enable interrupt on floating-point error	002100
DFI	Disable interrupt on floating-point error	002200
ERI	Enable interrupt on operand (address) range error	002300
DRI	Disable interrupt on operand (address) range error	002400
DBM	Disable bidirectional memory transfers	002500
EBM	Enable bidirectional memory transfers	002600
CMR	Complete memory references	002700

Instruction 002100 sets the Floating-point Mode flag in the M register. Instruction 002200 clears the Floating-point Mode flag in the M register. The two instructions do not check the previous state of the flag. When set, the Floating-point Mode flag enables interrupts on floating-point range errors as described in section 4. Issuing either of these instructions also clears the Floating-Point Error Status flag.

Instruction 002300 sets the Operand Range Mode flag in the M register. Instruction 002400 clears the Operand Range Mode flag in the M register. The two instructions do not check the previous state of the flag. When set, the Operand Range Mode flag enables interrupts on operand (address) range errors as described in section 3.

Instruction 002500 disables the bidirectional memory mode. Instruction 002600 enables the bidirectional memory mode. Block reads and writes can operate concurrently in bidirectional memory mode. If the bidirectional memory mode is disabled, only block reads can operate concurrently.

Instruction 002700 assures completion of all memory references within a particular CPU issuing the instruction. Instruction 002700 does not issue until all memory references before this instruction are at the stage of execution where completion occurs in a fixed amount of time. For example, a load of any data that has been stored by the CPU issuing instruction CMR, 002700 is assured of receiving the updated data if the load is issued after the CMR instruction. Synchronization of memory references between processors can be done by this instruction in conjunction with semaphore instructions.

INSTRUCTIONS 0021 - 0027 (continued)

HOLD ISSUE CONDITIONS: Instructions 002500 and 002600, hold issue 2 CPs

Instruction 002700, ports A, B, C busy

Instruction 002700, scalar memory reference active in clock period 1, 2, or 3

A_k reserved (except A0)

EXECUTION TIME: Instruction issue, 1 CP

SPECIAL CASES: Instructions 002100 and 002200 are issued even if there are other floating-point operations in process resulting from previous issues. The interrupts are enabled or disabled at CP + 1; floating-point overflows occurring after that time cause interrupts if they are enabled even if the overflow is generated by a previously issued floating-point instruction.

Instructions 002300 and 002400 are issued even if there are other memory references in process resulting from previous issues. The interrupts are enabled or disabled at CP + 1; operand range errors occurring after that time cause interrupts if they are enabled even if the operand range error is generated by a previous memory reference.

INSTRUCTIONS 0030, 0034, 0036, and 0037

CAL Syntax	Description	Octal Code
VM S_j	Transmit (S_j) to VM register	0030 j 0
VM 0^{\dagger}	Clear VM register	003000
SM jk 1,TS	Test and set semaphore jk , $0 \leq jk \leq 31_{10}$	0034 jk
SM jk 0	Clear semaphore jk , $0 \leq jk \leq 31_{10}$	0036 jk
SM jk 1	Set semaphore jk , $0 \leq jk \leq 31_{10}$	0037 jk

Instruction 0030 j 0 enters the VM register with the contents of S_j . The VM register is cleared if the j designator is 0 in instruction 003000. These instructions are used in conjunction with the vector merge instructions (146 and 147) in which an operation is performed depending on the contents of VM.

Instruction 0034 jk tests and sets the semaphore designated by jk . If the semaphore is set, issue is held until the other CPU clears that semaphore. If the semaphore is clear, the instruction issues and sets the semaphore. If all CPUs in a cluster are holding issue on a test and set, the DL flag is set in the Exchange Package (if not in monitor mode) and an exchange occurs. If an interrupt occurs while a test and set instruction is holding in the CIP register, the WS flag in the Exchange Package sets, CIP and NIP registers clear, and an exchange occurs with the P register pointing to the test and set instruction. The SM register is 32 bits with SM0 being the most significant bit.

Instruction 0036 jk clears the semaphore designated by jk .

Instruction 0037 jk sets the semaphore designated by jk .

HOLD ISSUE CONDITIONS: For instruction 0030 j 0:
 S_j reserved (except S0)
 Instruction 003 in process, unit busy 1 CP
 Instruction 14 x in process, unit busy (VL)+5 CPs
 Instruction 175 in process, unit busy (VL)+5 CPs

[†] Special CAL syntax

INSTRUCTIONS 0030, 0034, 0036, and 0037 (continued)

HOLD ISSUE CONDITIONS: For instruction 0034 jk :
(continued) If current Cluster Number $\neq 0$ and SM_{jk} is set, holds issue until other CPU in the same cluster clears the semaphore.

EXECUTION TIME: Instruction issue, 1 CP

SPECIAL CASES: $(S_j)=0$ if $j=0$.

Instructions 0034 jk , 0036 jk , and 0037 jk are no-ops if $CLN=0$.

INSTRUCTION 004

CAL Syntax	Description	Octal Code
EX	Normal exit	004000

Instruction 004 causes an exchange sequence which voids the contents of the instruction buffers. If monitor mode is not in effect, the Normal Exit flag in the F register is set. All instructions issued before this instruction are run to completion; that is, when all results arrive at the operating registers because of previously issued instructions, an exchange sequence occurs to the Exchange Package designated by the contents of the XA register. The program address stored into the Exchange Package is advanced one count from the address of the normal exit instruction. Instruction 004 is used to issue a monitor request from a user program.

HOLD ISSUE CONDITIONS: Any A, S, or V register reserved

EXECUTION TIME: Instruction issue, 40 CPs; this time includes an exchange sequence (24 CPs) and a fetch operation (16 CPs).

SPECIAL CASES: None

INSTRUCTION 005

CAL Syntax	Description	Octal Code
J <i>Bjk</i>	Branch to (<i>Bjk</i>)	0050 <i>jk</i>

Instruction 005 sets the P register to the 24-bit parcel address specified by the contents of *Bjk* causing execution to continue at that address. The instruction is used to return from a subroutine.

HOLD ISSUE CONDITIONS: Instruction 034 or 035 in process

Instruction 025 issued in the previous CP

Second parcel in a different buffer, 2 CP delay

Second parcel not in a buffer

EXECUTION TIME:

Instruction issue:

Instruction parcel and following parcel both in a buffer and branch address in a buffer, 7 CPs

Instruction parcel and following parcel both in a buffer and branch address not in a buffer, 18 CPs. Additional time is needed if a memory conflict exists. The time to resolve a memory conflict depends on factors present.

SPECIAL CASES:

Instruction 0050*jk* executes as if it were a 2-parcel instruction. Even though the parcel following the first parcel of instruction 0050*jk* is not used, it can cause a delay of instruction 0050*jk* if it is out of buffer. See execution times above.

INSTRUCTION 006

CAL Syntax	Description	Octal Code
J <i>exp</i>	Branch to <i>ijkm</i>	006 <i>ijkm</i>

The 2-parcel instruction 006 sets the P register to the parcel address specified by the low-order 24 bits of the *ijkm* field. Execution continues at that address. The high-order bit of the *ijkm* field is ignored.

HOLD ISSUE CONDITIONS: Second parcel in different buffer, 2 CP delay

Second parcel not in a buffer

EXECUTION TIME:

Instruction issue:

Both parcels of instruction in the same buffer and branch address in a buffer, 5 CPs

Both parcels of instruction in the same buffer and branch address not in a buffer, 16 CPs.

Additional time is needed if a memory conflict exists. The time to resolve a memory conflict depends on factors present.

SPECIAL CASES:

None

INSTRUCTION 007

CAL Syntax	Description	Octal Code
R <i>exp</i>	Return jump to <i>ijk</i> m; set B00 to (P)+2.	007 <i>ijk</i> m

The 2-parcel instruction 007 sets register B00 to the address of the parcel following the second parcel of the instruction. The P register is then set to the parcel address specified by the low-order 24 bits of the *ijk*m field. Execution continues at that address. The high-order bit of the *ijk*m field is ignored. This instruction provides a return linkage for subroutine calls. The subroutine is entered through a return jump. The subroutine can return to the caller at the instruction following the call by executing a branch to the contents of the B00 register.

HOLD ISSUE CONDITIONS: Instruction 034 or 035 in process

Second parcel in a different buffer, 2 CP delay

Second parcel not in a buffer

EXECUTION TIME:

Instruction issue:

Both parcels of instruction in the same buffer and branch address in a buffer, 5 CPs

Both parcels of instruction in the same buffer and branch address not in a buffer, 16 CPs.

Additional time is needed if a memory conflict exists. The time to resolve a memory conflict depends on factors present.

SPECIAL CASES:

None

INSTRUCTIONS 010 - 013

CAL Syntax	Description	Octal Code
JAZ <i>exp</i>	Branch to <i>ijkm</i> if (A0)=0 (<i>i</i> ₂ =0)	010 <i>ijkm</i>
JAN <i>exp</i>	Branch to <i>ijkm</i> if (A0)≠0 (<i>i</i> ₂ =0)	011 <i>ijkm</i>
JAP <i>exp</i>	Branch to <i>ijkm</i> if (A0) positive, includes (A0)=0 (<i>i</i> ₂ =0)	012 <i>ijkm</i>
JAM <i>exp</i>	Branch to <i>ijkm</i> if (A0) negative (<i>i</i> ₂ =0)	013 <i>ijkm</i>

The 2-parcel instructions 010 through 013 test the contents of A0 for the condition specified by the *h* field. If the condition is satisfied, the P register is set to the parcel address specified by the low-order 24 bits of the *ijkm* field and execution continues at that address. The high-order bit of the *ijkm* field must be 0. If the condition is not satisfied, execution continues with the instruction following the branch instruction.

HOLD ISSUE CONDITIONS: A0 busy in any one of the previous 3 CPs

Second parcel in a different buffer, 2 CP delay

Second parcel not in a buffer

EXECUTION TIME:

Instruction issue for branch taken:

Both parcels of instruction in the same buffer, branch taken, and branch address in a buffer, 5 CPs

Both parcels of instruction in the same buffer, branch taken, and branch address not in a buffer; 16 CPs for a 32-bank machine, 18 CPs for a 16-bank machine. Additional time is needed if a memory conflict exists. The time to resolve a memory conflict is indeterminate.

Both parcels of instruction in different buffers, branch taken, and branch address in a buffer; 7 CPs.

Both parcels of instruction in different buffers, branch taken, and branch address not in a buffer; 18 CPs for a 32-bank machine, 20 CPs for a 16-bank machine.

INSTRUCTIONS 010 - 013 (continued)

EXECUTION TIME:
(continued)

Second parcel of instruction not in a buffer,
branch taken, and branch address in a buffer;
18 CPs for a 32-bank machine, 20 CPs for a
16-bank machine.

Second parcel of instruction not in a buffer,
branch taken, and branch address not in buffer;
29 CPs for a 32-bank machine, 33 CPs for a
16-bank machine.

Instruction issue for branch not taken:
Both parcels of instruction in the same buffer,
branch not taken, and next instruction in the
same instruction buffer, 2 CPs

Both parcels of instruction in the same buffer,
branch not taken, and next instruction in
different instruction buffer, 4 CPs

Both parcels of instruction in the same buffer
and branch not taken with next instruction in
memory; 16 CPs for a 32-bank machine, 18 CPs
for a 16-bank machine.

Both parcels of instruction in different
buffers and branch not taken; 4 CPs.

Second parcel of instruction not in a buffer
and branch not taken; 15 CPs for a 32-bank
machine, 17 CPs for a 16-bank machine.

NOTE

Whenever a fetch occurs, memory conflicts may produce a
delay.

SPECIAL CASES:

(A0)=0 is considered a positive condition.

High-order bit of i designator (i_2) must be
0.

INSTRUCTIONS 014 - 017

CAL Syntax	Description	Octal Code
JSZ <i>exp</i>	Branch to <i>ijkm</i> if (S0)=0 (<i>i</i> ₂ =0)	014 <i>ijkm</i>
JSN <i>exp</i>	Branch to <i>ijkm</i> if (S0)≠0 (<i>i</i> ₂ =0)	015 <i>ijkm</i>
JSP <i>exp</i>	Branch to <i>ijkm</i> if (S0) positive, includes (S0)=0 (<i>i</i> ₂ =0)	016 <i>ijkm</i>
JSM <i>exp</i>	Branch to <i>ijkm</i> if (S0) negative (<i>i</i> ₂ =0)	017 <i>ijkm</i>

The 2-parcel instructions 014 through 017 test the contents of S0 for the condition specified by the *h* field. If the condition is satisfied, the P register is set to the parcel address specified by the low-order 24 bits of the *ijkm* field and execution continues at that address. The high-order bit of the *ijkm* field must be 0. If the condition is not satisfied, execution continues with the instruction following the branch instruction.

HOLD ISSUE CONDITIONS: S0 busy in any one of the previous 3 CPs

Second parcel in a different buffer, 2 CP delay

Second parcel not in a buffer

EXECUTION TIME:

Instruction issue for branch taken:

Both parcels of instruction in the same buffer, branch taken, and branch address in a buffer, 5 CPs

Both parcels of instruction in the same buffer, branch taken, and branch address not in a buffer; 16 CPs for a 32-bank machine, 18 CPs for a 16-bank machine. Additional time is needed if a memory conflict exists. The time to resolve a memory conflict is indeterminate.

Both parcels of instruction in different buffers, branch taken, and branch address in a buffer; 7 CPs.

Both parcels of instruction in different buffers, branch taken, and branch address not in a buffer; 18 CPs for a 32-bank machine, 20 CPs for a 16-bank machine.

INSTRUCTIONS 014 - 017 (continued)

EXECUTION TIME:
(continued)

Second parcel of instruction not in a buffer,
branch taken, and branch address in a buffer;
18 CPs for a 32-bank machine, 20 CPs for a
16-bank machine.

Second parcel of instruction not in a buffer,
branch taken, and branch address not in buffer;
29 CPs for a 32-bank machine, 33 CPs for a
16-bank machine.

Instruction issue for branch not taken:
Both parcels of instruction in the same buffer,
branch not taken, and next instruction in the
same instruction buffer, 2 CPs

Both parcels of instruction in the same buffer,
branch not taken, and next instruction in
different instruction buffer, 4 CPs

Both parcels of instruction in the same buffer
and branch not taken with next instruction in
memory; 16 CPs for a 32-bank machine, 18 CPs
for a 16-bank machine.

Both parcels of instruction in different
buffers and branch not taken; 4 CPs.

Second parcel of instruction not in a buffer
and branch not taken; 15 CPs for a 32-bank
machine, 17 CPs for a 16-bank machine.

NOTE

Whenever a fetch occurs, memory conflicts may produce a
delay.

SPECIAL CASES:

(S0)=0 is considered a positive condition.

High-order bit of i designator (i_2) must be 0.

INSTRUCTIONS 020 - 021

CAL Syntax	Description	Octal Code
A_i <i>exp</i>	Transmit jkm to A_i	020 $i.jkm$
A_i <i>exp</i>	Transmit ones complement of jkm to A_i	021 $i.jkm$

The 2-parcel instruction 020 enters a 24-bit value into A_i composed of the 22-bit jkm field and 2 high-order bits of 0.

The 2-parcel instruction 021 enters a 24-bit value that is the complement of a value formed by the 22-bit jkm field and 2 high-order bits of 0 into A_i . The complement is formed by changing all 1 bits to 0 and all 0 bits to 1. Thus, for instruction 021, the high-order 2 bits of A_i are set to 1. The instruction provides a means of entering a negative value into A_i . However, if the instruction is used to enter a negative number, the positive number used in the jkm field must be one smaller than the absolute value of the expected final negative number.

HOLD ISSUE CONDITIONS: A_i reserved

Second parcel not in a buffer

EXECUTION TIME:

Instruction issue:

Both parcels in same buffer, 2 CPs

Both parcels in different buffers, 4 CPs

A_i ready, 1 CP

SPECIAL CASES:

None

INSTRUCTION 022

CAL Syntax	Description	Octal Code
A_i <i>exp</i>	Transmit jk to A_i	022 ijk

Instruction 022 enters the 6-bit quantity from the jk field into the low-order 6 bits of A_i . The high-order 18 bits of A_i are zeroed. No sign extension occurs.

HOLD ISSUE CONDITIONS: A_i reserved

EXECUTION TIME: Instruction issue, 1 CP

A_i ready, 1 CP

SPECIAL CASES: None

INSTRUCTION 023

CAL Syntax	Description	Octal Code
A_i S_j	Transmit (S_j) to A_i	023 i j 0
A_i VL	Read vector length	023 i 01

Instruction 023 i j 0 enters the low-order 24 bits of (S_j) into A_i . The high-order bits of (S_j) are ignored.

Instruction 023 i 01 enters the content of the VL register into A_i .

HOLD ISSUE CONDITIONS: A_i reserved

For instruction 023 i j 0, S_j reserved
(except S_0)

EXECUTION TIME: Instruction issue, 1 CP

A_i ready, 1 CP

SPECIAL CASES: (S_j)=0 if $j=0$.

If (A_1)=0, the sequence:

VL A_1
A2 VL
leaves (A_2)=100₈

If (A_1)=23₈, the sequence:

VL A_1
A2 VL
leaves (A_2)=23₈

If (A_1)=123₈, the sequence:

VL A_1
A2 VL
leaves (A_2)=23₈

The 2^6 bit in the VL is a 1 if the low-order 6 bits are 0; otherwise, the 2^6 bit is a 0.

INSTRUCTIONS 024 - 025

CAL Syntax	Description	Octal Code
<i>Ai Bjk</i>	Transmit (<i>Bjk</i>) to <i>Ai</i>	024 <i>ijk</i>
<i>Bjk Ai</i>	Transmit (<i>Ai</i>) to <i>Bjk</i>	025 <i>ijk</i>

Instruction 024 enters the contents of *Bjk* into *Ai*.

Instruction 025 enters the contents of *Ai* into *Bjk*.

HOLD ISSUE CONDITIONS: Instruction 034 or 035 in process

For instruction 024*ijk*, instruction 025*ijk*
issued in previous CP

Ai reserved

EXECUTION TIME: For instruction 024, *Ai* ready, 1 CP

Instruction issue, 1 CP

SPECIAL CASES: None

INSTRUCTION 026

CAL Syntax	Description	Octal Code
A_i PS j	Population count of (S j) to A_i	026 i j 0
A_i QS j	Population count parity of (S j) to A_i	026 i j 1
A_i SB j	Transfer (SB j) to A_i	026 i j 7

Instruction 026 i j 0 counts the number of bits set to 1 in (S j) and enters the result into the low-order 7 bits of A_i . The high-order 17 bits of A_i are zeroed. If (S j)=0, then (A_i)=0.

Instruction 026 i j 1 counts the number of bits set to 1 in (S j). Then, the low-order bit, showing the odd/even state of the result is transferred to the low-order bit position of the A_i register. The high-order 23 bits are cleared. The actual population count is not transferred.

Instructions 026 i j 0 and 026 i j 1 are executed in the Population/Leading Zero Count functional unit.

Instruction 026 i j 7 transfers the contents of the SB j register shared between the CPUs to A_i .

HOLD ISSUE CONDITIONS: A_i reserved

S j reserved (except S0)

For instruction 026 i j 7, hold issue 1 CP, then 2+[†] CP more after A_i not reserved.
Minimum 3 CP hold.

EXECUTION TIME: Instruction issue, 1 CP

For instructions 026 i j 0 and 026 i j 1, A_i ready 4 CPs

For instruction 026 i j 7, A_i ready 1 CP

[†] If more than one CPU attempts to access semaphores or shared registers in the same clock period, a scanner will resolve the conflict. See shared register explanation in section 2.

SPECIAL CASES:

For instructions $026ij0$ and $026ij1$, $(Ai)=0$ if $j=0$.

For instruction $026ij7$, $(Ai)=0$ if $CLN=0$.

For instruction $026ij7$:

If instruction $027ij7$, write SBj , has just been issued within the previous 2 CPs, then the original value (instead of new value) of (SBj) is delivered to Ai as a result of this instruction.

INSTRUCTION 027

CAL Syntax	Description	Octal Code
A_i Z S_j	Leading zero count of (S_j) to A_i	027 ij_0
SB j A_i	Transfer (A_i) to SB j	027 ij_7

Instruction 027 ij_0 counts the number of leading zeros in S_j and enters the result into the low-order 7 bits of A_i . The high-order 17 bits of A_i are zeroed. Instruction 027 ij_0 is executed in the Population/Leading Zero Count functional unit.

Instruction 027 ij_7 stores (A_i) to the SB j register, which is shared between the CPUs in the same cluster.

HOLD ISSUE CONDITIONS: For instruction 027 ij_0 , instruction 033 issued in CP 2

A_i reserved

S_j reserved (except S0)

For instruction 027 ij_7 , hold issue 1 CP, then 2+[†] CP more after A_i not reserved. Minimum 3 CP hold.

EXECUTION TIME: Instruction issue, 1 CP

For instruction 027 ij_7 , SB j ready 1 CP

For instruction 027 ij_0 , A_i , ready 3 CPs

SPECIAL CASES: For instruction 027 ij_0 , $(A_i)=64$ if $j=0$.

For instruction 027 ij_0 , $(A_i)=0$ if (S_j) is negative.

Instruction 027 ij_7 is a no-op if CLN=0.

[†] If more than one CPU attempts to access semaphores or shared registers in the same clock period, a scanner will resolve the conflict. See shared register explanation in section 2.

INSTRUCTIONS 030 - 031

CAL Syntax	Description	Octal Code
$A_i \ A_j + A_k$	Integer sum of (A_j) and (A_k) to A_i	030 i_jk
$A_i \ A_k^\dagger$	Transmit (A_k) to A_i	030 $i0k$
$A_i \ A_j + 1^\dagger$	Integer sum of (A_j) and 1 to A_i	030 i_j0
$A_i \ A_j - A_k$	Integer difference (A_j) less (A_k) to A_i	031 i_jk
$A_i \ -1^\dagger$	Transmit -1 to A_i	031 $i00$
$A_i \ -A_k^\dagger$	Transmit the negative of (A_k) to A_i	031 $i0k$
$A_i \ A_j - 1^\dagger$	Integer difference (A_j) less 1 to A_i	031 i_j0

Instruction 030 forms the integer sum of (A_j) and (A_k) and enters the result into A_i . No overflow is detected.

Instruction 031 forms the integer difference of (A_j) and (A_k) and enters the result into A_i . No overflow is detected.

Instructions 030 and 031 are executed in the Address Add functional unit.

HOLD ISSUE CONDITIONS: A_i reserved

A_j or A_k reserved (except A0)

EXECUTION TIME: Instruction issue, 1 CP

A_i ready, 2 CPs

SPECIAL CASES:

For instruction 030:

$(A_i) = (A_k)$ if $j=0$ and $k \neq 0$.

$(A_i) = 1$ if $j=0$ and $k=0$.

$(A_i) = (A_j) + 1$ if $j \neq 0$ and $k=0$.

For instruction 031:

$(A_i) = -(A_k)$ if $j=0$ and $k \neq 0$.

$(A_i) = -1$ if $j=0$ and $k=0$.

$(A_i) = (A_j) - 1$ if $j \neq 0$ and $k=0$.

\dagger Special CAL syntax

INSTRUCTION 032

CAL Syntax	Description	Octal Code
$A_i \quad A_j * A_k$	Integer product of (A_j) and (A_k) to A_i	032ijk

Instruction 032 forms the integer product of (A_j) and (A_k) and enters the low-order 24 bits of the result into A_i . No overflow is detected.

Instruction 032 is executed in the Address Multiply functional unit.

HOLD ISSUE CONDITIONS: A_i reserved

A_j or A_k reserved (except A0)

EXECUTION TIME: Instruction issue, 1 CP

A_i ready, 4 CPs

SPECIAL CASES:

$(A_i) = 0$ if $j = 0$.

$(A_k) = 1$ if $k = 0$.

Thus, $(A_i) = (A_j)$ if $j \neq 0$ and $k = 0$.

INSTRUCTION 033

CAL Syntax	Description	Octal Code
A_i CI	Channel number of highest priority interrupt request to A_i	033 i 00
A_i CA, A_j	Current address of channel (A_j) to A_i	033 i j 0
A_i CE, A_j	Error flag of channel (A_j) to A_i	033 i j 1

Instruction 033 enters channel status information into A_i . The j and k designators and the contents of A_j define the desired information.

The channel number of the highest priority interrupt request is entered into A_i when the j designator is 0. The contents of A_j specify a channel number when the j designator is nonzero. The value of the Current Address (CA) register for the channel is entered into A_i when the k designator is 0. The error flag for the channel is entered into the low-order bit of A_i when the k designator is 1. The high-order bits of A_i are cleared. The error flag can be cleared only in monitor mode using instruction 0012.

Instruction 033 does not interfere with channel operation and is not protected from user execution.

HOLD ISSUE CONDITIONS: A_i reserved

A_j reserved (except A0)

EXECUTION TIME: Instruction issue, 1 CP

A_i ready, 4 CPs

SPECIAL CASES: (A_i)=Highest priority channel causing interrupt if (A_j)=0.

(A_i)=Current address of channel (A_j) if (A_j) \neq 0 and k =0.

(A_i)=I/O error flag of channel (A_j) if (A_j) \neq 0 and k =1.

(A_i)=0 if (A_j)=1.

INSTRUCTION 033 (continued)

SPECIAL CASES:
(continued)

2 CPs must elapse after instruction 0012j0 issues before issuing instruction 033i00

If instruction 033 issues every 10 CPs (in a loop), the same results may be returned to A(i).

When $k=1$:

Bits 2^{12} through 2^{20} contain the remaining block length.

Bit 2^{18} indicates a request in progress.

Bit 2^{19} will return a 0.

Bit 2^{20} indicates a block length error.

Bit 2^{21} indicates either an SSD double-bit memory error (during a read SSD operation) or an SSD double-bit channel error (during a write SSD operation).

Bit 2^{22} indicates a CPU double-bit memory error.

Bit 2^{23} indicates a fatal error (if bit 2^{20} , 2^{21} , or 2^{22} is set).

INSTRUCTIONS 034 - 037

CAL Syntax	Description	Octal Code
$Bjk, Ai, A0$	Block transfer (Ai) words from memory starting at address ($A0$) to B registers starting at register jk	034 ijk
$Bjk, Ai, 0, A0$ [†]	Block transfer (Ai) words from memory starting at address ($A0$) to B registers starting at register jk	034 ijk
$, A0 Bjk, Ai$	Block transfer (Ai) words from B registers starting at register jk to memory starting at address ($A0$)	035 ijk
$0, A0 Bjk, Ai$ [†]	Block transfer (Ai) words from B registers starting at register jk to memory starting at address ($A0$)	035 ijk
$Tjk, Ai, A0$	Block transfer (Ai) words from memory starting at address ($A0$) to T registers starting at register jk	036 ijk
$Tjk, Ai, 0, A0$ [†]	Block transfer (Ai) words from memory starting at address ($A0$) to T registers starting at register jk	036 ijk
$, A0 Tjk, Ai$	Block transfer (Ai) words from T registers starting at register jk to memory starting at address ($A0$)	037 ijk
$0, A0 Tjk, Ai$ [†]	Block transfer (Ai) words from T registers starting at register jk to memory starting at address ($A0$)	037 ijk

Instructions 034 through 037 perform block transfers between memory and B or T registers.

In all the instructions, the amount of data transferred is specified by the low-order 7 bits of (Ai). See special cases for details.

The first register involved in the transfer is specified by jk . Successive transfers involve successive B or T registers until B77 or T77 is reached. Since processing of the registers is circular, B00 is processed after B77 and T00 is processed after T77 if the count in (Ai) is not exhausted.

[†] Special CAL syntax

INSTRUCTIONS 034 - 037 (continued)

The first memory location referenced by the transfer instruction is specified by (A0). The A0 register contents are not altered by execution of the instruction. Memory references are incremented by 1 for successive transfers.

For transfers of B registers to memory, each 24-bit value is right adjusted in the word, high-order 40 bits are zeroed. When transferring from memory to B registers, only low-order 24 bits are transmitted; high-order 40 bits are ignored.

HOLD ISSUE CONDITIONS: A0 reserved

A_i reserved

Scalar reference in CP1, CP2, or CP3

For instruction 034, Port A busy or instruction 035 in process or uni-directional memory mode and Port C busy

For instruction 035, Port C busy or instruction 034 in process or uni-directional memory mode and Port A or Port B busy

For instruction 036, Port B busy or instruction 037 in process or uni-directional memory mode and Port C busy

For instruction 037, Port C busy or instruction 036 in process or uni-directional memory mode and Port A or Port B busy

EXECUTION TIME: Instruction issue, 1 CP

For instruction 034 or 036:

B or T register reserved 16 CPs + (A_i) if $(A_i) \neq 0$; 6 CPs if $(A_i) = 0$.

Port A or B busy for (A_i) + 5 CPs if $(A_i) \neq 0$; 4 CPs if $(A_i) = 0$.

For instruction 035 or 037:

B or T register reserved 5 CPs + (A_i) if $(A_i) \neq 0$; 4 CPs if $(A_i) = 0$.

Port C busy for (A_i) + 5 CPs if $(A_i) \neq 0$; 4 CPs if $(A_i) = 0$.

INSTRUCTIONS 034 - 037 (continued)

SPECIAL CASES:

$(A_i)=0$ causes a zero-block transfer.

(A_i) in the range greater than 100_8 and less than 200_8 causes a wrap-around condition.

If (A_i) is greater than 177_8 , bits 2^7 through 2^{23} are truncated. The block length is equal to the value of 2^0 through 2^6 .

NOTE

Instruction 034 uses Port A, instruction 035 uses Port C, instruction 036 uses Port B, and instruction 037 uses Port C.

INSTRUCTIONS 040 - 041

CAL Syntax	Description	Octal Code
<i>Si exp</i>	Transmit <i>jkm</i> to <i>Si</i>	040 <i>ijkm</i>
<i>Si exp</i>	Transmit complement of <i>jkm</i> to <i>Si</i>	041 <i>ijkm</i>

The 2-parcel instructions 040 and 041 enter immediate values into an S register.

Instruction 040 enters a 64-bit value composed of the 22-bit *jkm* field and 42 high-order bits of 0 into *Si*.

Instruction 041 enters a 64-bit value that is the complement of a value formed by the 22-bit *jkm* field and 42 high-order bits of 0 into *Si*. The complement is formed by changing all 1 bits to 0 and all 0 bits to 1. Thus, for instruction 041, the high-order 42 bits of *Si* are set to 1's. The instruction provides for entering a negative value into *Si*. Since the register value is the ones complement of *jkm*, to get the twos complement *jkm* should be 0 to get -1, 1 to get -2, 3 to get -4, etc.

HOLD ISSUE CONDITIONS: *Si* reserved

Second parcel not in a buffer

EXECUTION TIME:

Instruction issue:

Both parcels in same buffer, 2 CPs

Both parcels in different buffers, 4 CPs

Si ready, 1 CP

SPECIAL CASES:

None

INSTRUCTIONS 042 - 043

CAL Syntax	Description	Octal Code
$S_i <exp$	Form exp bits of ones mask in S_i from right; jk field gets $64-exp$.	$042ijk$
$S_i \#>exp^\dagger$	Form exp bits of zeros mask in S_i from left; jk field gets exp .	$042ijk$
$S_i 1^\dagger$	Enter 1 into S_i	$042i77$
$S_i -1^\dagger$	Enter -1 into S_i	$042i00$
$S_i >exp$	Form exp bits of ones mask in S_i from left; jk field gets exp .	$043ijk$
$S_i \#<exp^\dagger$	Form exp bits of zeros mask in S_i from right; jk field gets $64-exp$.	$043ijk$
$S_i 0^\dagger$	Clear S_i	$043i00$

Instruction 042 generates a mask of $64-jk$ ones from right to left in S_i . For example, if $jk=0$, S_i contains all 1 bits (integer value=-1) and if $jk=77_8$, S_i contains zeros in all but the low-order bit (integer value=1).

Instruction 043 generates a mask of jk ones from left to right in S_i . For example, if $jk=0$, S_i contains all 0 bits (integer value=0) and if $jk=77_8$, S_i contains ones in all but the low-order bit (integer value=-2).

Instructions 042 and 043 are executed in the Scalar Logical functional unit.

HOLD ISSUE CONDITIONS: S_i reserved

EXECUTION TIME: Instruction issue, 1 CP

S_i ready, 1 CP

SPECIAL CASES: None

\dagger Special CAL syntax

INSTRUCTIONS 044 - 051

CAL Syntax	Description	Octal Code
$S_i S_j \& S_k$	Logical product of (S_j) and (S_k) to S_i	044ijk
$S_i S_j \& SB^\dagger$	Sign bit of (S_j) to S_i	044ij0
$S_i SB \& S_j^\dagger$	Sign bit of (S_j) to S_i ($j \neq 0$)	044ij0
$S_i \#S_k \& S_j$	Logical product of (S_j) and complement of (S_k) to S_i	045ijk
$S_i \#SB \& S_j^\dagger$	(S_j) with sign bit cleared to S_i	045ij0
$S_i S_j S_k$	Logical difference of (S_j) and (S_k) to S_i	046ijk
$S_i S_j SB^\dagger$	Toggle sign bit of (S_j) , then enter into S_i	046ij0
$S_i SB S_j^\dagger$	Toggle sign bit of (S_j) , then enter into S_i ($j \neq 0$)	046ij0
$S_i \#S_j S_k$	Logical equivalence of (S_k) and (S_j) to S_i	047ijk
$S_i \#S_k^\dagger$	Transmit ones complement of (S_k) to S_i	047i0k
$S_i \#S_j SB^\dagger$	Logical equivalence of (S_j) and sign bit to S_i	047ij0
$S_i \#SB S_j^\dagger$	Logical equivalence of (S_j) and sign bit to S_i ($j \neq 0$)	047ij0
$S_i \#SB^\dagger$	Enter ones complement of sign bit into S_i	047i00
$S_i S_j !S_i \& S_k$	Scalar merge	050ijk
$S_i S_j !S_i \& SB^\dagger$	Scalar merge of (S_i) and sign bit of (S_j) to S_i	050ij0
$S_i S_j !S_k$	Logical sum of (S_j) and (S_k) to S_i	051ijk
$S_i S_k^\dagger$	Transmit (S_k) to S_i	051i0k
$S_i S_j !SB^\dagger$	Logical sum of (S_j) and sign bit to S_i	051ij0
$S_i SB !S_j^\dagger$	Logical sum of (S_j) and sign bit to S_i ($j \neq 0$)	051ij0
$S_i SB^\dagger$	Enter sign bit into S_i	051i00

\dagger Special CAL syntax

INSTRUCTIONS 044 - 051 (continued)

NOTE

For instructions 044 through 051, SB with no register designator is the sign bit, not Shared Address register.

Instructions 044 through 051 are executed in the Scalar Logical functional unit.

Instruction 044 forms the logical product (AND) of (S_j) and (S_k) and enters the result into S_i . Bits of S_i are set to 1 when corresponding bits of (S_j) and (S_k) are 1 as in the following example:

$$\begin{array}{r} (S_j) = 1\ 1\ 0\ 0 \\ (S_k) = \underline{1\ 0\ 1\ 0} \\ (S_i) = 1\ 0\ 0\ 0 \end{array}$$

(S_j) is transmitted to S_i if the j and k designators have the same nonzero value. S_i is cleared if the j designator is 0. The sign bit of (S_j) is transmitted to S_i if the j designator is nonzero and the k designator is 0.

Instruction 045 forms the logical product (AND) of (S_j) and the complement of (S_k) and enters the result into S_i . Bits of S_i are set to 1 when corresponding bits of (S_j) and the complement of (S_k) are 1 as in the following example where $(S_k') =$ complement of (S_k) :

if $(S_k) = 1\ 0\ 1\ 0$

$$\begin{array}{r} (S_j) = 1\ 1\ 0\ 0 \\ (S_k') = \underline{0\ 1\ 0\ 1} \\ (S_i) = 0\ 1\ 0\ 0 \end{array}$$

S_i is cleared if the j and k designators have the same value or if the j designator is 0. (S_j) with the sign bit cleared is transmitted to S_i if the j designator is nonzero and the k designator is 0.

Instruction 046 forms the logical difference (exclusive OR) of (S_j) and (S_k) and enters the result into S_i . Bits of S_i are set to 1 when corresponding bits of (S_j) and (S_k) are different as in the following example:

$$\begin{array}{r} (S_j) = 1\ 1\ 0\ 0 \\ (S_k) = \underline{1\ 0\ 1\ 0} \\ (S_i) = 0\ 1\ 1\ 0 \end{array}$$

INSTRUCTIONS 044 - 051 (continued)

S_i is cleared if the j and k designators have the same nonzero value. (S_k) is transmitted to S_i if the j designator is 0 and the k designator is nonzero. The sign bit of (S_j) is complemented and the result is transmitted to S_i if the j designator is nonzero and the k designator is 0.

Instruction 047 forms the logical equivalence of (S_j) and (S_k) and enters the result into S_i . Bits of S_i are set to 1 when corresponding bits of (S_j) and (S_k) are the same as in the following example:

$$\begin{aligned} (S_j) &= 1\ 1\ 0\ 0 \\ (S_k) &= \underline{1\ 0\ 1\ 0} \\ (S_i) &= 1\ 0\ 0\ 1 \end{aligned}$$

S_i is set to all ones if the j and k designators have the same nonzero value. The complement of (S_k) is transmitted to S_i if the j designator is 0 and the k designator is nonzero. All bits except the sign bit of (S_j) are complemented and the result is transmitted to S_i if the j designator is nonzero and the k designator is 0. The result is the complement produced by instruction 046.

Instruction 050 merges the contents of (S_j) with (S_i) depending on the ones mask in S_k . The result is defined by the following Boolean equation where S_k' is the complement of S_k as illustrated:

$$(S_i) = (S_j)(S_k) + (S_i)(S_k')$$

$$\text{if } (S_k) = 1\ 1\ 1\ 1\ 0\ 0\ 0\ 0$$

$$\begin{aligned} (S_k') &= 0\ 0\ 0\ 0\ 1\ 1\ 1\ 1 \\ (S_i) &= 1\ 1\ 0\ 0\ 1\ 1\ 0\ 0 \\ (S_j) &= \underline{1\ 0\ 1\ 0\ 1\ 0\ 1\ 0} \\ (S_i) &= 1\ 0\ 1\ 0\ 1\ 1\ 0\ 0 \end{aligned}$$

Instruction 050 is intended for merging portions of 64-bit words into a composite word. Bits of S_i are cleared when the corresponding bits of S_k are 1 if the j designator is 0 and the k designator is nonzero. The sign bit of (S_j) replaces the sign bit of S_i if the j designator is nonzero and the k designator is 0. The sign bit of S_i is cleared if the j and k designators are both 0.

Instruction 051 forms the logical sum (inclusive OR) of (S_j) and (S_k) and enters the result into S_i . Bits of S_i are set when 1 of the corresponding bits of (S_j) and (S_k) is set as in the following example:

$$\begin{aligned} (S_j) &= 1\ 1\ 0\ 0 \\ (S_k) &= \underline{1\ 0\ 1\ 0} \\ (S_i) &= 1\ 1\ 1\ 0 \end{aligned}$$

INSTRUCTIONS 044 - 051 (continued)

(S_j) is transmitted to S_i if the j and k designators have the same nonzero value. (S_k) is transmitted to S_i if the j designator is 0 and the k designator is nonzero. (S_j) with the sign bit set to 1 is transmitted to S_i if the j designator is nonzero and the k designator is 0. A ones mask consisting of only the sign bit is entered into S_i if the j and k designators are both 0.

HOLD ISSUE CONDITIONS: S_i reserved

S_j or S_k reserved (except S_0)

EXECUTION TIME: Instruction issue, 1 CP

S_i ready, 1 CP

SPECIAL CASES: $(S_j)=0$ if $j=0$.

$(S_k)=2^{63}$ if $k=0$.

INSTRUCTIONS 052 - 055

CAL Syntax	Description	Octal Code
S0 <i>Si</i> < <i>exp</i>	Shift (<i>Si</i>) left <i>exp=jk</i> places to S0	052 <i>ijk</i>
S0 <i>Si</i> > <i>exp</i>	Shift (<i>Si</i>) right <i>exp=64-jk</i> places to S0	053 <i>ijk</i>
<i>Si</i> <i>Si</i> < <i>exp</i>	Shift (<i>Si</i>) left <i>exp=jk</i> places to <i>Si</i>	054 <i>ijk</i>
<i>Si</i> <i>Si</i> > <i>exp</i>	Shift (<i>Si</i>) right <i>exp=64-jk</i> places to <i>Si</i>	055 <i>ijk</i>

Instructions 052 through 055 are executed in the Scalar Shift functional unit. They shift values in an S register by an amount specified by *jk*. All shifts are end off with zero fill.

Instruction 052 shifts (*Si*) left *jk* places and enters the result into S0. Shift range is 0 through 63 left.

Instruction 053 shifts (*Si*) right by *64-jk* places and enters the result into S0. Shift range is 1 through 64 right.

Instruction 054 shifts (*Si*) left *jk* places and enters the result into *Si*. Shift range is 0 through 63 left.

Instruction 055 shifts (*Si*) right by *64-jk* places and enters the result into *Si*. Shift range is 1 through 64 right.

HOLD ISSUE CONDITIONS: Instruction 056, 057, 060, or 061 issued in previous CP

Si reserved

For instructions 052 and 053, S0 reserved

EXECUTION TIME: Instruction issue, 1 CP

For instructions 052 and 053, S0 ready, 2 CPs

For instructions 054 and 055, *Si* ready, 2 CPs

SPECIAL CASES: None

INSTRUCTIONS 056 - 057

CAL Syntax	Description	Octal Code
$S_i S_j, S_j < A_k$	Shift (S_i) and (S_j) left by (A_k) places to S_i	056ijk
$S_i S_j, S_j < 1^\dagger$	Shift (S_i) and (S_j) left one place to S_i	056ij0
$S_i S_i < A_k^\dagger$	Shift (S_i) left (A_k) places to S_i	056i0k
$S_i S_j, S_i > A_k$	Shift (S_j) and (S_i) right by (A_k) places to S_i	057ijk
$S_i S_j, S_i > 1^\dagger$	Shift (S_j) and (S_i) right one place to S_i	057ij0
$S_i S_i > A_k^\dagger$	Shift (S_i) right (A_k) places to S_i	057i0k

Instructions 056 and 057 are executed in the Scalar Shift functional unit. They shift 128-bit values formed by logically joining two S registers. Shift counts are obtained from register A_k . All shift counts, (A_k) , are considered positive and all 24 bits of (A_k) are used for the shift count. A shift of one place occurs if the k designator is 0. If $j=0$, the shifts function as if the shifted value were 64 bits rather than 128 bits since the S_j value used is 0.

The shifts are circular if the shift count does not exceed 64 and the i and j designators are equal and nonzero. For instructions 056 and 057, (S_j) is unchanged, provided $i \neq j$. For shifts greater than 64, the shift is end off with zero fill. If $i=j$ and the shift is greater than 64, the shift is the same as if the respective instruction 054 or 055 was used with a shift count 64 less.

Instruction 056 performs left shifts of (S_i) and (S_j) with (S_i) initially the most significant bits of the double register. The high-order 64 bits of the result are transmitted to S_i . S_i is cleared if the shift count exceeds 127. Instruction 056 produces the same result as instruction 054 if the shift count does not exceed 63 and the j designator is 0.

Instruction 057 performs right shifts of (S_j) and (S_i) with (S_j) initially the most significant bits of the double register. The low-order 64 bits of the result are transmitted to S_i . S_i is cleared if the shift count exceeds 127. Instruction 057 produces the same result as instruction 055 if the shift count does not exceed 63 and the j designator is 0.

[†] Special CAL syntax

INSTRUCTIONS 056 - 057 (continued)

HOLD ISSUE CONDITIONS: S_i reserved
 S_j or A_k reserved (except S_0 and/or A_0)

EXECUTION TIME: Instruction issue, 1 CP
 S_i ready, 3 CPs

SPECIAL CASES: $(S_j)=0$ if $j=0$.
 $(A_k)=1$ if $k=0$.
Circular shift if $i=j \neq 0$ and A_k greater than or equal to 0 and less than or equal to 64.

INSTRUCTIONS 060 - 061

CAL Syntax	Description	Octal Code
$S_i \ S_j+S_k$	Integer sum of (S_j) and (S_k) to S_i	060ijk
$S_i \ S_j-S_k$	Integer difference of (S_j) and (S_k) to S_i	061ijk
$S_i \ -S_k^\dagger$	Transmit negative of (S_k) to S_i	061i0k

Instruction 060 forms the integer sums of (S_j) and (S_k) and enters the result into S_i . No overflow is detected.

Instruction 061 forms the integer difference of (S_j) and (S_k) and enters the result into S_i . No overflow is detected.

Instructions 060 and 061 are executed in the Scalar Add functional unit.

HOLD ISSUE CONDITIONS: S_i reserved

S_j or S_k reserved (except S_0)

EXECUTION TIME: S_i ready, 3 CPs

Instruction issue, 1 CP

SPECIAL CASES: $(S_i)=2^{63}$ if $j=0$ and $k=0$.

For instruction 060:

$(S_i)=(S_k)$ if $j=0$ and $k \neq 0$.

$(S_i)=(S_j)$ with 2^{63} complemented if $j \neq 0$ and $k=0$.

For instruction 061:

$(S_i) = -(S_k)$ if $j=0$ and $k \neq 0$.

$(S_i)=(S_j)$ with 2^{63} complemented if $j \neq 0$ and $k=0$.

[†] Special CAL syntax

INSTRUCTIONS 062 - 063

CAL Syntax	Description	Octal Code
$S_i \ S_j + F S_k$	Floating-point sum of (S_j) and (S_k) to S_i	062 <i>ijk</i>
$S_i \ + F S_k^\dagger$	Normalize (S_k) to S_i	062 <i>i0k</i>
$S_i \ S_j - F S_k$	Floating-point difference of (S_j) and (S_k) to S_i	063 <i>ijk</i>
$S_i \ - F S_k^\dagger$	Transmit normalized negative of (S_k) to S_i	063 <i>i0k</i>

Instructions 062 and 063 are performed in the Floating-point Add functional unit. Operands are assumed to be in floating-point format. The result is normalized even if the operands are not normalized.

Instruction 062 forms the sum of the floating-point quantities in S_j and S_k and enters the normalized result into S_i .

Instruction 063 forms the difference of the floating-point quantities in S_j and S_k and enters the normalized result into S_i .

Overflow conditions are described in section 4. For floating-point operands with the sign bit set (bit=1), zero exponent and zero coefficient are treated as 0 (that is, all 64 bits=0).^{††}

HOLD ISSUE CONDITIONS: S_i reserved

S_j or S_k reserved (except S_0)

Instructions 170 through 173 in process, unit busy (VL) + 4 CPs

EXECUTION TIME: Instruction issue, 1 CP

S_i ready, 6 CPs

[†] Special CAL syntax

^{††} Considered -0. No floating-point unit generates a -0 except the Floating-point Multiply functional unit if one of the operands was a -0. Normally, -0 occurs in logical manipulations when a sign is attached to a number; that number can be 0.

INSTRUCTIONS 062 - 063 (continued)

SPECIAL CASES:

For instruction 062:

$(S_i) = (S_k)$ normalized if (S_k) exponent is valid, $j=0$ and $k \neq 0$.

$(S_i) = (S_j)$ normalized if (S_j) exponent is valid, $j \neq 0$ and $k=0$.

For instruction 063:

$(S_i) = -(S_k)$ normalized if (S_k) exponent is valid, $j=0$ and $k \neq 0$. Sign of (S_i) is opposite that of (S_k) if $(S_k) \neq 0$.

$(S_i) = (S_j)$ normalized if (S_j) exponent is valid, $j \neq 0$ and $k=0$.

INSTRUCTIONS 064 - 067

CAL Syntax	Description	Octal Code
$S_i \quad S_j * F S_k$	Floating-point product of (S_j) and (S_k) to S_i	064ijk
$S_i \quad S_j * H S_k$	Half-precision rounded floating-point product of (S_j) and (S_k) to S_i	065ijk
$S_i \quad S_j * R S_k$	Rounded floating-point product of (S_j) and (S_k) to S_i	066ijk
$S_i \quad S_j * I S_k$	Reciprocal iteration; $2 - (S_j) * (S_k)$ to S_i	067ijk

Instructions 064 through 067 are executed in the Floating-point Multiply functional unit. Operands are assumed to be in floating-point format. The result is not guaranteed to be normalized if the operands are not normalized.

Instruction 064 forms the product of the floating-point quantities in S_j and S_k and enters the result into S_i .

Instruction 065 forms the half-precision rounded product of the floating-point quantities in S_j and S_k and enters the result into S_i . The low-order 19 bits of the result are cleared.

Instruction 066 forms the rounded product of the floating-point quantities in S_j and S_k and enters the result into S_i .

Instruction 067 forms two minus the product of the floating-point quantities in S_j and S_k and enters the result into S_i . This instruction is used in the divide sequence as described in section 4 under Floating-point Arithmetic.

In the evaluation $C = 2 - B * A$, B must be a reciprocal of A of less than 47 significant bits and not the exact reciprocal, otherwise C will be in error. The reciprocal produced by the reciprocal approximation instruction meets this criterion.

HOLD ISSUE CONDITIONS: S_i reserved

S_j or S_k reserved (except S_0)

Instructions 160 through 167 in process, unit busy (VL) + 4 CPs

For mainframes with a Second Vector Logical unit: instructions 140 through 145 in process, unit busy (VL) + 4 CPs.

INSTRUCTIONS 064 - 067 (continued)

EXECUTION TIME: Instruction issue, 1 CP

S_i ready, 7 CPs

SPECIAL CASES: $(S_j)=0$ if $j=0$.

$(S_k)=2^{63}$ if $k=0$.

If both exponent fields are 0, an integer multiply is performed. Correct integer multiply results are produced if the following conditions are met:

- Both operand sign bits are 0.
- The sum of the 0 bits to the right of the least significant 1 bit in the two operands is greater than or equal to 48.

The integer result obtained is the high-order 48 bits of the 96-bit product of the two operands.

INSTRUCTION 070

CAL Syntax	Description	Octal Code
S_i / HS_j	Floating-point reciprocal approximation of (S_j) to S_i	070 i_j 0

Instruction 070 is executed in the Reciprocal Approximation functional unit.

Instruction 070 forms an approximation to the reciprocal of the normalized floating-point quantity in S_j and enters the result into S_i . This instruction occurs in the divide sequence to compute the quotient of two floating-point quantities as described in section 4 under Floating-point Arithmetic.

The reciprocal approximation instruction produces a result of 30 significant bits. The low-order 18 bits are zeros. The number of significant bits can be extended to 48 using the reciprocal iteration instruction and a multiply.

HOLD ISSUE CONDITIONS: S_i reserved

S_j reserved (except S_0)

Instruction 174 in process, unit busy (VL) + 4 CPs

EXECUTION TIME: S_i ready, 14 CPs

Instruction issue, 1 CP

SPECIAL CASES: (S_i) is meaningless if (S_j) is not normalized; the unit assumes that bit 2^{47} of $(S_j)=1$; no test is made of this bit.

$(S_j)=0$ produces a range error; the result is meaningless.

$(S_j)=0$ if $j=0$.

INSTRUCTION 071

CAL Syntax	Description	Octal Code
$S_i \ A_k$	Transmit (A_k) to S_i with no sign extension	071i0k
$S_i \ +A_k$	Transmit (A_k) to S_i with sign extension	071i1k
$S_i \ +FA_k$	Transmit (A_k) to S_i as unnormalized floating-point number	071i2k
$S_i \ 0.6$	Transmit constant 0.75×2^{48} to S_i	071i30
$S_i \ 0.4$	Transmit constant 0.5 to S_i	071i40
$S_i \ 1.$	Transmit constant 1.0 to S_i	071i50
$S_i \ 2.$	Transmit constant 2.0 to S_i	071i60
$S_i \ 4.$	Transmit constant 4.0 to S_i	071i70

Instruction 071 performs functions that depend on the value of the j designator. The functions are concerned with transmitting information from an A register to an S register and with generating frequently used floating-point constants.

When the j designator is 0, the 24-bit value in A_k is transmitted to S_i . The value is treated as an unsigned integer. The high-order bits of S_i are zeros.

When the j designator is 1, the 24-bit value in A_k is transmitted to S_i . The value is treated as a signed integer. The sign bit of A_k is extended through the high-order bit of S_i .

When the j designator is 2, the 24-bit value in A_k is transmitted to S_i as an unnormalized floating-point quantity (the result is then added to 0 to normalize). For this instruction, the exponent in bits 2^{62} through 2^{48} is set to 40060_8 . The sign of the coefficient is set according to the sign of A_k . If the sign bit of A_k is set, the twos complement of A_k is entered into S_i as the magnitude of the coefficient and bit 2^{63} of S_i is set for the sign of the coefficient.

A sequence of instructions is used to convert an integer whose absolute value is less than 24 bits to floating-point format:

```

CAL code:  A1  S1
           S1  +FA1
           S1  +FS1      9 CPs required
    
```

INSTRUCTION 071 (continued)

When the j designator is 3, the floating-point constant of 0.75×2^{48} is entered into S_i (0 40060 6000 0000 0000 0000₈). This constant is used to create floating-point numbers from integer numbers (positive and negative) whose absolute value is less than 47 bits. A sequence of instructions is used for conversion of an integer in S_1 :

CAL code: S_2 0.6
 S_1 S_2-S_1
 S_1 S_2-FS_1 11 CPs required

When the j designator is 4, the floating-point constant 0.5 (= 0 40000 4000 0000 0000 0000₈) is entered into S_i .

When the j designator is 5, the floating-point constant 1.0 (= 0 40001 4000 0000 0000 0000₈) is entered into S_i .

When the j designator is 6, the floating-point constant 2.0 (= 0 40002 4000 0000 0000 0000₈) is entered into S_i .

When the j designator is 7, the floating-point constant 4.0 (= 0 40003 4000 0000 0000 0000₈) is entered into S_i .

HOLD ISSUE CONDITIONS: S_i reserved

A_k reserved (except A_0); applies to all forms of the instruction, that is, j designators 0 through 7.

EXECUTION TIME: Instruction issue, 1 CP

S_i ready, 2 CPs

SPECIAL CASES:

$(A_k)=1$ if $k=0$.

$(S_i)=(A_k)$ if $j=0$.

$(S_i)=(A_k)$ sign extended if $j=1$.

$(S_i)=(A_k)$ unnormalized if $j=2$.

$(S_i)=0.6 \times 2^{60}$ (octal) if $j=3$.

$(S_i)=0.4 \times 2^0$ (octal) if $j=4$.

$(S_i)=0.4 \times 2^1$ (octal) if $j=5$.

$(S_i)=0.4 \times 2^2$ (octal) if $j=6$.

$(S_i)=0.4 \times 2^3$ (octal) if $j=7$.

INSTRUCTIONS 072 - 075

CAL Syntax	Description	Octal Code
S_i RT	Transmit (RTC) to S_i	072 <i>i</i> 00
S_i SM	Read semaphores to S_i	072 <i>i</i> 02
S_i ST <i>j</i>	Read (ST <i>j</i>) register to S_i	072 <i>i</i> <i>j</i> 3
S_i VM	Transmit (VM) to S_i	073 <i>i</i> 00
†	Read performance counter into S_i	073 <i>i</i> 11
†	Increment performance counter	073 <i>i</i> 21
†	Clear all maintenance modes	073 <i>i</i> 31
S_i SR <i>j</i>	Transmit (SR <i>j</i>) to S_i ; $j=0$	073 <i>i</i> <i>j</i> 1
SM S_i	Load semaphores from S_i	073 <i>i</i> 02
ST <i>j</i> S_i	Load (ST <i>j</i>) register from S_i	073 <i>i</i> <i>j</i> 3
S_i T <i>j</i> <i>k</i>	Transmit (T <i>j</i> <i>k</i>) to S_i	074 <i>i</i> <i>j</i> <i>k</i>
T <i>j</i> <i>k</i> S_i	Transmit (S_i) to T <i>j</i> <i>k</i>	075 <i>i</i> <i>j</i> <i>k</i>

Instruction 072*i*00 enters the 64-bit value of the real-time clock (RTC) into S_i . The clock is incremented by 1 each CP. The RTC can be set only by the monitor through use of instruction 0014*j*0.

Instruction 072*i*02 enters the values of all of the semaphores into S_i . The 32-bit SM register is left justified in S_i with SM00 occupying the sign bit.

Instruction 072*i**j*3 enters the contents of ST*j* into S_i .

Instruction 073*i*00 enters the 64-bit value of the VM register into S_i . The VM register is usually read after being set by instruction 175.

Instruction 073*i*11 is used for performance monitoring and is privileged to monitor mode. Each execution of the 073*i*11 instruction advances a pointer and enters either the high- or low-order bits of a performance counter into the high-order bits of S_i . See Appendix C for information on performance monitoring.

† Not supported at present time

Instructions 073i21 and 073i31 are part of the SECEDED maintenance mode functions and are executed only if the maintenance mode switch on the mainframe's control panel is on. Instruction 073i21 enables certain data bits to replace the 8 check bits used for SECEDED as they are written into memory for any subsequent write to memory (except for I/O write to memory). Instruction 073i31 clears all three SECEDED maintenance mode instructions: 001501, 001521, and 001531. See Appendix D for complete information on the SECEDED maintenance modes.

Instruction 073ij1 enters the contents of the Status register SRj into Si. Instruction 073i01 returns the following status to the high-order bits of Si:

<u>Si Bit</u>	<u>Description</u>
263	Clustered, CLN # 0 (CL)
257	Program state (PS)
251	Floating-point error occurred (FPS)
250	Floating-point interrupt enabled (IFP)
249	Operand range interrupt enabled (IOR)
248	Bidirectional memory enabled (BDM)
240†	Processor number bit 0 (PN0)
233†	Cluster number bit 1 (CLN1)
232†	Cluster number bit 0 (CLN0)

Instruction 073i02 sets the semaphores from 32 high-order bits of Si. SM00 receives the sign bit of Si.

Instruction 073ij3 enters the contents of Si into STj.

Instruction 074 enters the contents of Tjk into Si.

Instruction 075 enters the contents of Si into Tjk.

HOLD ISSUE CONDITIONS: Si reserved

For instructions 074 and 075, instructions 036 through 037 in process

For instruction 074, instruction 075 issued in the previous CP

For instruction 073i00:

Instruction 14x or 175 in process, VM busy for (VL) + 5 CPs

Instruction 003 in process, VM busy for 1 CP

† These bit positions return a value of 0 if not executed in monitor mode.

INSTRUCTIONS 072 - 075 (continued)

HOLD ISSUE CONDITIONS: For instructions 072*ij*3, 073*ij*3 and 73*i*02, (continued) hold issue 1 CP, then 2+[†] CP more after *Si* not reserved. Minimum 3 CP hold.

EXECUTION TIME: Instruction issue, 1 CP

Result register ready 1 CP

For 073*i*02, SM ready, 1 CP

SPECIAL CASES: For instructions 072*i*02 and 072*ij*3, (*Si*)=0 if CLN=0.

Instructions 073*i*02 and 073*ij*3 are no-ops if CLN=0.

There must be a 2 CP delay between sequential 073*ill* instructions.

[†] If more than one CPU attempts to access semaphores or shared registers in the same clock period, a scanner will resolve the conflict. See shared register explanation in section 2.

INSTRUCTIONS 076 - 077

CAL Syntax	Description	Octal Code
$S_i \ V_j, A_k$	Transmit (V_j element (A_k)) to S_i	076ijk
$V_i, A_k \ S_j$	Transmit (S_j) to V_i element (A_k)	077ijk
$V_i, A_k \ 0^\dagger$	Clear V_i element (A_k)	077i0k

Instructions 076 and 077 transmit a 64-bit quantity between a V register element and an S register.

Instruction 076 transmits the contents of an element of register V_j to S_i .

Instruction 077 transmits the contents of register S_j to an element of register V_i .

The low-order 6 bits of (A_k) determine the vector element for either instruction.

HOLD ISSUE CONDITIONS: A_k reserved (except A0)

For instruction 076, S_i reserved or V_j reserved as operand or as result

For instruction 077, V_i reserved as operand or as result or S_j reserved

EXECUTION TIME: Instruction issue, 1 CP

For instruction 076, S_i ready, 4 CPs

For instruction 077, V_i ready, 1 CP

SPECIAL CASES: (S_j)=0 if $j=0$.

(A_k)=1 if $k=0$.

[†] Special CAL syntax

INSTRUCTIONS 10 h - 13 h

CAL Syntax	Description	Octal Code
$Ai\ exp, Ah$	Read from $((Ah) + jkm)$ to Ai	10 $hi.jkm$
$Ai\ exp, 0^\dagger$	Read from (jkm) to Ai	100 $i.jkm$
$Ai\ exp, ^\dagger$	Read from (jkm) to Ai	100 $i.jkm$
$Ai\ , Ah^\dagger$	Read from (Ah) to Ai	10 $hi00\ 0$
$exp, Ah\ Ai$	Store (Ai) to $(Ah) + jkm$	11 $hi.jkm$
$exp, 0\ Ai^\dagger$	Store (Ai) to jkm	110 $i.jkm$
$exp, \ Ai^\dagger$	Store (Ai) to exp	110 $i.jkm$
$, Ah\ Ai^\dagger$	Store (Ai) to (Ah)	11 $hi00\ 0$
$Si\ exp, Ah$	Read from $((Ah) + jkm)$ to Si	12 $hi.jkm$
$Si\ exp, 0^\dagger$	Read from (exp) to Si	120 $i.jkm$
$Si\ exp, ^\dagger$	Read from (exp) to Si	120 $i.jkm$
$Si\ , Ah^\dagger$	Read from (Ah) to Si	12 $hi00\ 0$
$exp, Ah\ Si$	Store (Si) to $(Ah) + jkm$	13 $hi.jkm$
$exp, 0\ Si^\dagger$	Store (Si) to exp	130 $i.jkm$
$exp, \ Si^\dagger$	Store (Si) to exp	130 $i.jkm$
$, Ah\ Si^\dagger$	Store (Si) to (Ah)	13 $hi00\ 0$

The 2-parcel instructions 10 h through 13 h transmit data between memory and an A register or an S register. The content of Ah (treated as a 22-bit signed integer) is added to the signed 22-bit integer in the jkm field to determine the memory address. If h is 0, (Ah) is 0 and only the jkm field is used for the address. The address arithmetic is performed by an address adder similar to but separate from the Address Add functional unit.

\dagger Special CAL syntax

INSTRUCTIONS 10h - 13h (continued)

Instructions 10h and 11h transmit 24-bit quantities to or from A registers. When transmitting data from memory to an A register, the high-order 40 bits of the memory word are ignored. On a store from Ai into memory, the high-order 40 bits of the memory word are zeroed.

Instructions 12h and 13h transmit 64-bit quantities to or from register Si.

HOLD ISSUE CONDITIONS: Port A, B, or C busy

Ah reserved or busy previous CP

For instructions 10h and 11h, Ai reserved

For instructions 12h and 13h, Si reserved

Instructions 10x through 13x in CP 2 and CP 3 and conflict

Second parcel not in a buffer

Second parcel in different buffer, 2 CP

EXECUTION TIME:

Instruction issue:

Both parcels in same buffer, 2 CPs

For instruction 10h, Ai ready, 14 CPs

For instruction 12h, Si ready, 14 CPs

Bank ready for next scalar read or store, 4 CPs

NOTE

After issuing instructions 10h through 13h, attempting to issue instructions 034 through 037, 176, or 177 causes Ports A, B, or C to be considered busy for 4 CPs (plus additional CPs if there are conflicts).

SPECIAL CASES:

None

INSTRUCTIONS 140 - 147

CAL Syntax	Description	Octal Code
$V_i S_j \& V_k$	Logical products of (S_j) and (V_k elements) to V_i elements	140ijk
$V_i V_j \& V_k$	Logical products of (V_j elements) and (V_k elements) to V_i elements	141ijk
$V_i S_j ! V_k$	Logical sums of (S_j) and (V_k elements) to V_i elements	142ijk
$V_i V_k^\dagger$	Transmit (V_k elements) to V_i elements	142i0k
$V_i V_j ! V_k$	Logical sums of (V_j elements) and (V_k elements) to V_i elements	143ijk
$V_i S_j \setminus V_k$	Logical differences of (S_j) and (V_k elements) to V_i elements	144ijk
$V_i V_j \setminus V_k$	Logical differences of (V_j elements) and (V_k elements) to V_i elements	145ijk
$V_i 0^\dagger$	Clear V_i elements	145iii
$V_i S_j ! V_k \& VM$	If VM bit=1, transmit (S_j) to the corresponding element in V_i If VM bit=0, transmit the (corresponding V_k element) to the (corresponding V_i element)	146ijk
$V_i \#VM \& V_k^\dagger$	If VM bit=1, transmit (0) to the corresponding element in V_i If VM bit=0, transmit the (corresponding V_k element) to the (corresponding V_i element)	146i0k
$V_i V_j ! V_k \& VM$	If VM bit=1, transmit the (corresponding V_j element) to the (corresponding V_i element) If VM bit=0, transmit the (corresponding V_k element) to the (corresponding V_i element)	147ijk

On mainframes equipped with Second Vector Logical functional units, instructions 140 through 145 can be executed in either the Full Vector or the Second Vector Logical units, provided the Second Vector Logical unit is enabled. If the Second Vector Logical unit is disabled, instructions 140 through 145 can be executed only in the Full Vector Logical unit.

\dagger Special CAL syntax

INSTRUCTIONS 140 - 147 (continued)

Instructions 146 and 147 execute in the Full Vector Logical unit only. The number of operations performed is determined by the contents of the VL register. All operations start with element 0 of the V_i , V_j , or V_k register and increment the element number by 1 for each operation performed. All results are delivered to V_i .

For instructions 140, 142, 144, and 146, a copy of the content of S_j is delivered to the functional unit. The copy of the content is held as one of the operands until completion of the operation. Therefore, S_j can be changed immediately without affecting the vector operation. For instructions 141, 143, 145, and 147, all operands are obtained from V registers.

Instructions 140 and 141 form the logical products (AND) of operand pairs and enter the result into V_i . Bits of an element of V_i are set to 1 when the corresponding bits of (S_j) or (V_j element) and (V_k element) are 1 as in the following:

$$\begin{aligned} (S_j) \text{ or } (V_j \text{ element}) &= 1\ 1\ 0\ 0 \\ (V_k \text{ element}) &= \underline{1\ 0\ 1\ 0} \\ (V_i \text{ element}) &= 1\ 0\ 0\ 0 \end{aligned}$$

Instructions 142 and 143 form the logical sums (inclusive OR) of operand pairs and deliver the results to V_i . Bits of an element of V_i are set to 1 when one of the corresponding bits of (S_j) or (V_j element) and (V_k element) is 1 as in the following:

$$\begin{aligned} (S_j) \text{ or } (V_j \text{ element}) &= 1\ 1\ 0\ 0 \\ (V_k \text{ element}) &= \underline{1\ 0\ 1\ 0} \\ (V_i \text{ element}) &= 1\ 1\ 1\ 0 \end{aligned}$$

Instructions 144 and 145 form the logical differences (exclusive OR) of operand pairs and deliver the results of V_i . Bits of an element are set to 1 when the corresponding bit of (S_j) or (V_j element) is different from (V_k element) as in the following:

$$\begin{aligned} (S_j) \text{ or } (V_j \text{ element}) &= 1\ 1\ 0\ 0 \\ (V_k \text{ element}) &= \underline{1\ 0\ 1\ 0} \\ (V_i \text{ element}) &= 0\ 1\ 1\ 0 \end{aligned}$$

Instructions 146 and 147 transmit operands to V_i depending on the contents of the VM register. Bit 2^{63} of the mask corresponds to element 0 of a V register. Bit 2^0 corresponds to element 63. Operand pairs used for the selection depend on the instruction. For instruction 146, the first operand is always (S_j), the second operand is (V_k element). For instruction 147, the first operand is (V_j element) and the second operand is (V_k element). If bit n of the vector mask is 1, the first operand is transmitted; if bit n of the mask is 0, the second operand, (V_k element), is selected.

INSTRUCTIONS 140 - 147 (continued)

Examples:

1. If instruction 146 is to be executed and the following register conditions exist:

(VL) = 4
(VM) = 0 60000 0000 0000 0000 0000
(S2) = -1
(V600) = 1
(V601) = 2
(V602) = 3
(V603) = 4

Instruction 146726 is executed. Following execution, the first four elements of V7 contain the following values:

(V700) = 1
(V701) = -1
(V702) = -1
(V703) = 4

The remaining elements of V7 are unaltered.

2. If instruction 147 is to be executed and the following register conditions exist:

(VL) = 4
(VM) = 0 600000 0000 0000 0000 0000
(V200) = 1 (V300) = -1
(V201) = 2 (V301) = -2
(V202) = 3 (V302) = -3
(V203) = 4 (V303) = -4

Instruction 147123 is executed. Following execution, the first four elements of V1 contain the following values:

(V100) = -1
(V101) = 2
(V102) = 3
(V103) = -4

The remaining elements of V1 are unaltered.

HOLD ISSUE CONDITIONS: V_k reserved as operand

V_i reserved as operand or result

For instructions 140, 142, 144, and 146, S_j reserved

INSTRUCTIONS 140 - 147 (continued)

HOLD ISSUE CONDITIONS: For instructions 141, 143, 145, and 147, V_j
(continued) reserved as operand

For instructions 146 and 147, or instructions 140 through 145 with Second Vector Logical disabled:^{††}

Instruction 14 x or 175 in process, Full Vector Logical unit busy (VL) + 4 CPs

For instructions 140 through 145 with Second Vector Logical unit enabled:^{††}

See discussion on Second Vector Logical issue in section 4

Instructions 140 through 145 or 16 x in process in Second Vector Logical^{††}/Floating-point Multiply unit, Second Vector Logical unit busy (VL) + 4 CPs

Instruction 140 through 147 or 175 in process in Full Vector Logical unit, Full Vector Logical unit busy (VL) + 4 CPs

EXECUTION TIME: Instruction issue, 1 CP

V_j or V_k ready in (VL) + 3 CPs if data available[†]

If data available,[†] V_i ready in (VL) + 7 CPs if Full Vector Logical unit is used, 9 CPs if Second Vector Logical unit is used.^{††}

Unit ready, (VL) + 4 CPs if data available[†]

SPECIAL CASES: $(S_j)=0$ if $j=0$.

[†] Vector instructions may or may not start execution immediately; they execute as data becomes available. In particular, a memory conflict that slows execution of some elements of a vector load can cause delays in all instructions in the operation chain starting with that load.

^{††} Only on mainframes equipped with Second Vector Logical functional units

INSTRUCTIONS 150 - 151

CAL Syntax	Description	Octal Code
$V_i \quad V_j < A_k$	Shift (V_j) elements left by (A_k) places to V_i elements	150ijk
$V_i \quad V_j < 1^\dagger$	Shift (V_j) elements left one place to V_i elements	150ij0
$V_i \quad V_j > A_k$	Shift (V_j) elements right by (A_k) places to V_i elements	151ijk
$V_i \quad V_j > 1^\dagger$	Shift (V_j) elements right one place to V_i elements	151ij0

Instructions 150 and 151 are executed in the Vector Shift functional unit. The number of operations performed is determined by the contents of the VL register. Operations start with element 0 of the V_i and V_j registers and end with elements specified by (VL)-1.

All shifts are end off with zero fill. The shift count is obtained from (A_k) and all 24 bits of A_k are used for the shift count. Elements of V_i are cleared if the shift count exceeds 63. All shift counts (A_k) are considered positive.

Unlike shift instructions 052 through 055, these instructions receive the shift count from A_k , rather than the jk fields.

HOLD ISSUE CONDITIONS: V_j reserved as operand

V_i reserved as operand or result

A_k reserved (except A0)

Instructions 150 through 153 in process, unit busy (VL) + 4 Cps^{††}

[†] Special CAL syntax

^{††} Vector instructions may or may not start execution immediately; they execute as data becomes available. In particular, a memory conflict that slows execution of some elements of a vector load can cause delays in all instructions in the operation chain starting with that load.

INSTRUCTIONS 150 - 151

EXECUTION TIME: V_j ready in (VL) + 3 CPs if data available[†]
 V_i ready in (VL) + 8 CPs if data available[†]
Unit ready, (VL) + 4 CPs if data available[†]

SPECIAL CASES: $(A_k)=1$ if $k=0$.

[†] Vector instructions may or may not start execution immediately; they execute as data becomes available. In particular, a memory conflict that slows execution of some elements of a vector load can cause delays in all instructions in the operation chain starting with that load.

INSTRUCTIONS 152 - 153

CAL Syntax	Description	Octal Code
$V_i V_j, V_j < A_k$	Double shifts of (V_j elements) left (A_k) places to V_i elements	152ijk
$V_i V_j, V_j < 1^\dagger$	Double shifts of (V_j elements) left one place to V_i elements	152ij0
$V_i V_j, V_j > A_k$	Double shifts of (V_j elements) right (A_k) places to V_i elements	153ijk
$V_i V_j, V_j > 1^\dagger$	Double shifts of (V_j elements) right one place to V_i elements	153ij0

Instructions 152 and 153 are executed in the Vector Shift functional unit. The instructions shift 128-bit values formed by logically joining the contents of two elements of the V_j register. The direction of the shift determines whether the high-order bits or the low-order bits of the result are sent to V_i . Shift counts are obtained from register A_k .

All shifts are end off with zero fill.

The number of operations is determined by the contents of the VL register.

Instruction 152 performs left shifts. The operation starts with element 0 of V_j . If (VL) is 1, element 0 is joined with 64 bits of 0, and the resulting 128-bit quantity is then shifted left by the amount specified by (A_k). Only the one operation is performed. The 64 high-order bits remaining are transmitted to element 0 of V_i .

If (VL) is 2, the operation starts with element 0 of V_j being joined with element 1, and the resulting 128-bit quantity is then shifted left by the amount specified by (A_k). The high-order 64 bits remaining are transmitted to element 0 of V_i . Figure 5-7 illustrates this operation.

If (VL) is greater than 2, the operation continues by joining element 1 with element 2 and transmitting the 64-bit result to element 1 of V_i . Figure 5-8 illustrates this operation.

If (VL) is 2, element 1 is joined with 64 bits of 0 and only two operations are performed. In general, the last element of V_j as determined by (VL) is joined with 64 bits of zeros. Figure 5-9 illustrates this operation.

[†] Special CAL syntax

INSTRUCTIONS 152 - 153 (continued)

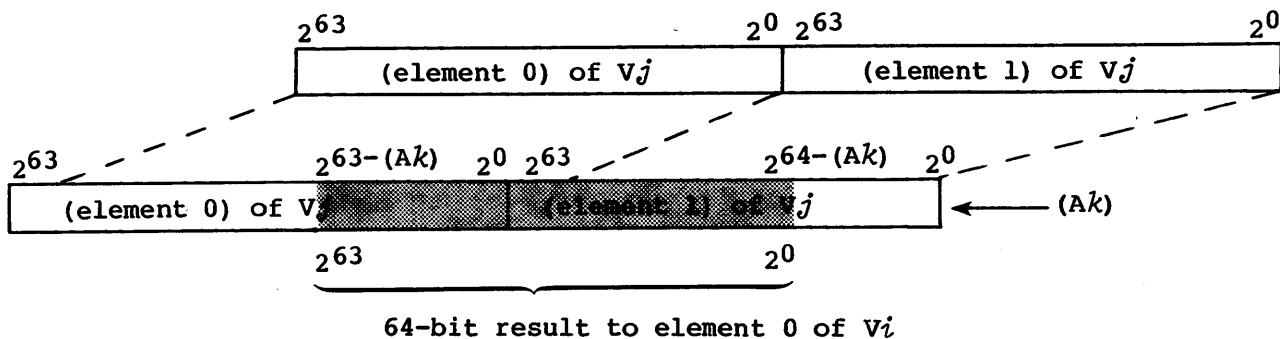

Figure 5-7. Vector left double shift, first element, VL greater than 1

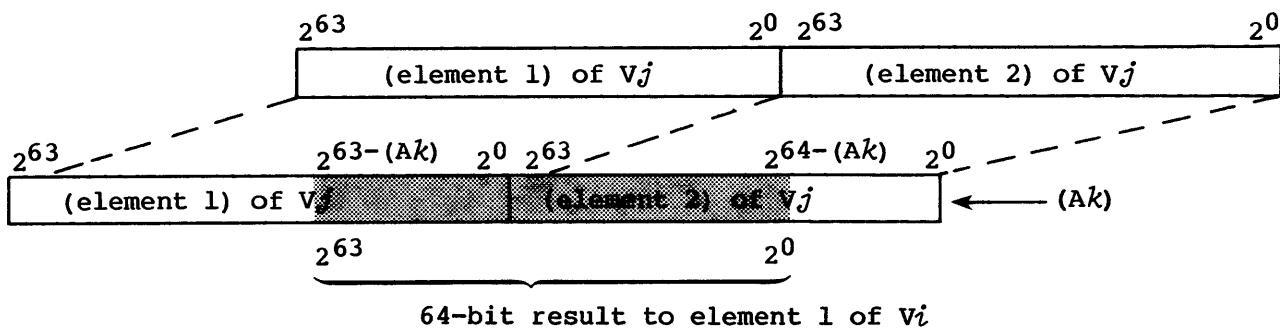

Figure 5-8. Vector left double shift, second element, VL greater than 2

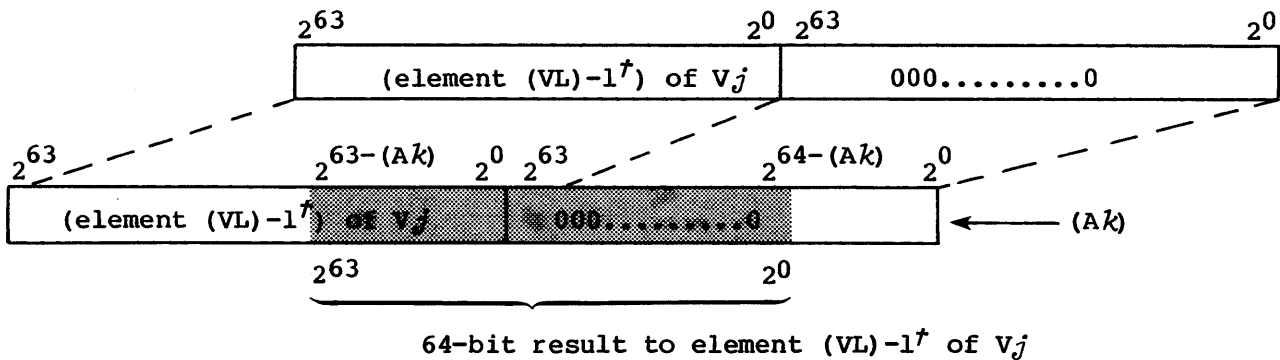

Figure 5-9. Vector left double shift, last element

[†] Elements are numbered 0 through 63 in the V registers; therefore, element $(VL)-1$ refers to the VL^{th} element.

INSTRUCTIONS 152 - 153 (continued)

If (Ak) is greater than or equal to 128, the result is all zeros. If (Ak) is greater than 64, the result register contains at least $(Ak) - 64$ zeros.

Examples:

1. If instruction 152 is to be executed and the following register conditions exist:

```
(VL) = 4
(AL) = 3
(V400) = 0 00000 0000 0000 0000 0007
(V401) = 0 60000 0000 0000 0000 0005
(V402) = 1 00000 0000 0000 0000 0006
(V403) = 1 60000 0000 0000 0000 0007
```

Instruction 152541 is executed. Following execution, the first four elements of V5 contain the following values:

```
(V500) = 0 00000 0000 0000 0000 0073
(V501) = 0 00000 0000 0000 0000 0054
(V502) = 0 00000 0000 0000 0000 0067
(V503) = 0 00000 0000 0000 0000 0070
```

Instruction 153 performs right shifts. The original element 0 of V_j is joined with 64 high-order bits of 0 and the 128-bit quantity is shifted right by the amount specified by (Ak) . The 64 low-order bits of the result are transmitted to element 0 of V_i . Figure 5-10 illustrates this operation.

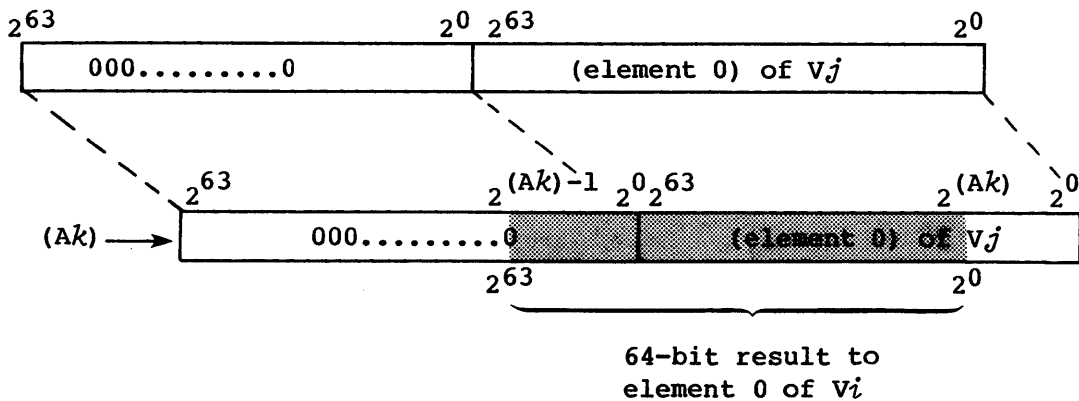

Figure 5-10. Vector right double shift, first element

If $(VL)=1$, only one operation is performed. In general, however, instruction execution continues by joining element 0 with element 1, shifting the 128-bit quantity by the amount specified by (Ak) , and

INSTRUCTIONS 152 - 153 (continued)

transmitting the result to element 1 of V_i . This operation is shown in figure 5-11.

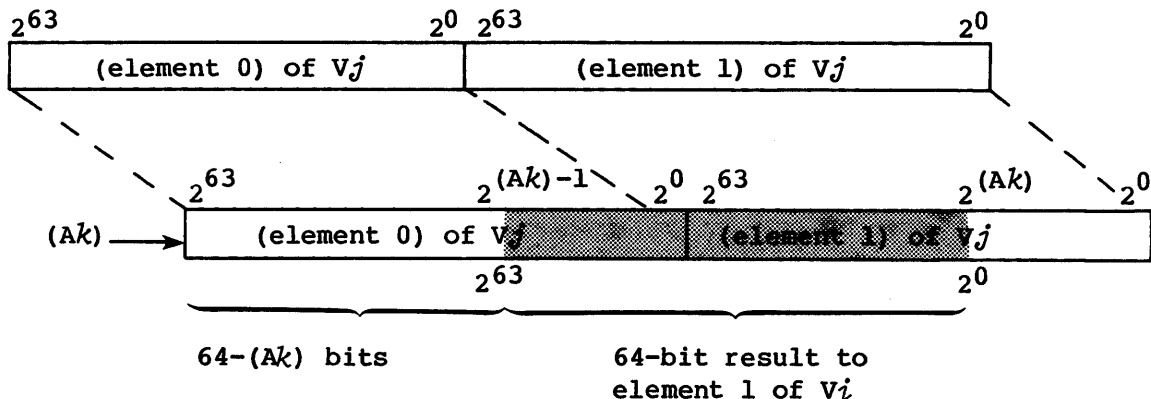

Figure 5-11. Vector right double shift, second element, VL greater than 1

The last operation performed by the instruction joins the last element of V_j as determined by (VL) with the preceding element. Figure 5-12 illustrates this operation.

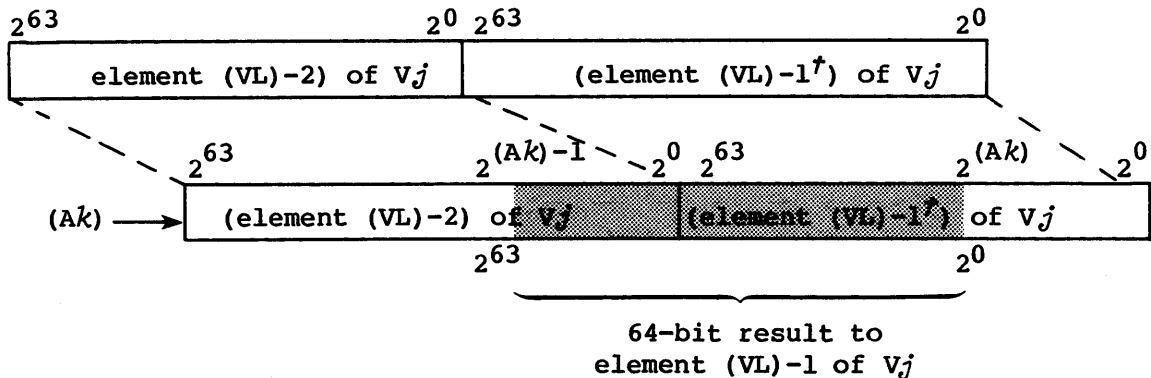

Figure 5-12. Vector right double shift, last operation

2. If an instruction 153 is to be executed and the following register conditions exist:

* Elements are numbered 0 through 63 in the V registers; therefore, element (VL)-1 refers to the VLth element.

INSTRUCTIONS 152 - 153 (continued)

(VL) = 4
(A6) = 3
(V200) = 0 00000 0000 0000 0000 0017
(V201) = 0 60000 0000 0000 0000 0006
(V202) = 1 00000 0000 0000 0000 0006
(V203) = 1 60000 0000 0000 0000 0007

Instruction 153026 is executed and following execution, register V0 contains the following values:

(V000) = 0 00000 0000 0000 0000 0001
(V001) = 1 66000 0000 0000 0000 0000
(V002) = 1 50000 0000 0000 0000 0000
(V003) = 1 56000 0000 0000 0000 0000

The remaining elements of V0 are unaltered.

HOLD ISSUE CONDITIONS: V_j reserved as operand

V_i reserved as operand or result

A_k reserved (except A0)

Instructions 150 through 153 in process, unit busy (VL) + 4 CPS[†]

EXECUTION TIME: Instruction issue, 1 CP

V_j ready in (VL) + 3 CPS if data available[†]

For instruction 152, V_i ready in (VL) + 9 CPS if data available[†]

Instruction 153, V_i ready in (VL) + 8 CPS if data available[†]

Unit ready, (VL) + 4 CPS if data available[†]

SPECIAL CASES: $(A_k)=1$ if $k=0$.

[†] Vector instructions may or may not start execution immediately; they execute as data becomes available. In particular, a memory conflict that slows execution of some elements of a vector load can cause delays in all instructions in the operation chain starting with that load.

INSTRUCTIONS 154 - 157

CAL Syntax	Description	Octal Code
$V_i \ S_j + V_k$	Integer sums of (S_j) and (V_k elements) to V_i elements	154ijk
$V_i \ V_j + V_k$	Integer sums of (V_j elements) and (V_k elements) to V_i elements	155ijk
$V_i \ S_j - V_k$	Integer differences of (S_j) and (V_k elements) to V_i elements	156ijk
$V_i \ -V_k^\dagger$	Transmit negative of (V_k elements) to V_i elements	156i0k
$V_i \ V_j - V_k$	Integer differences of (V_j elements) and (V_k elements) to V_i elements	157ijk

Instructions 154 through 157 are executed in the Vector Add functional unit.

Instructions 154 and 155 perform integer addition. Instructions 156 and 157 perform integer subtraction. The number of additions or subtractions performed is determined by the contents of the VL register. All operations start with element 0 of the V registers and increment the element number by 1 for each operation performed. All results are delivered to elements of V_i . No overflow is detected.

Instructions 154 and 156 deliver a copy of (S_j) to the functional unit where the copy is retained as one of the operands until the vector operation completes. The other operand is an element of V_k . For instructions 155 and 157, both operands are obtained from V registers.

HOLD ISSUE CONDITIONS: V_k reserved as operand

V_i reserved as operand or result

Instructions 154 through 157 in process, unit busy (VL) + 4 CPs[†]

For instructions 154 and 156, S_j reserved (except S0)

For instructions 155 and 157, V_j reserved as operand

[†] Special CAL syntax

INSTRUCTIONS 154 - 157 (continued)

EXECUTION TIME: Instruction issue, 1 CP

V_j or V_k ready in (VL) + 3 CPs if data
 available[†]

V_i ready in (VL) + 8 CPs if data available[†]

 Unit ready, (VL) + 4 CPs if data available[†]

SPECIAL CASES: For instruction 154, if $j=0$, then $(S_j)=0$ and
 $(V_i \text{ element}) = (V_k \text{ element})$.

 For instruction 156, if $j=0$, then $(S_j)=0$ and
 $(V_i \text{ element}) = -(V_k \text{ element})$.

[†] Vector instructions may or may not start execution immediately; they execute as data becomes available. In particular, a memory conflict that slows execution of some elements of a vector load can cause delays in all instructions in the operation chain starting with that load.

INSTRUCTIONS 160 - 167

CAL Syntax	Description	Octal Code
V_i $S_j * FV_k$	Floating-point products of (S_j) and (V_k) elements to V_i elements	160ijk
V_i $V_j * FV_k$	Floating-point products of (V_j) elements and (V_k) elements to V_i elements	161ijk
V_i $S_j * HV_k$	Half-precision rounded floating-point products of (S_j) and (V_k) elements to V_i elements	162ijk
V_i $V_j * HV_k$	Half-precision rounded floating-point products of (V_j) elements and (V_k) elements to V_i elements	163ijk
V_i $S_j * RV_k$	Rounded floating-point products of (S_j) and (V_k) elements to V_i elements	164ijk
V_i $V_j * RV_k$	Rounded floating-point products of (V_j) elements and (V_k) elements to V_i elements	165ijk
V_i $S_j * IV_k$	Reciprocal iterations; 2 - $(S_j) * (V_k)$ elements to V_i elements	166ijk
V_i $V_j * IV_k$	Reciprocal iterations; 2 - (V_j) elements * (V_k) elements to V_i elements	167ijk

Instructions 160 through 167 are executed in the Floating-point Multiply functional unit. The number of operations performed by an instruction is determined by the contents of the VL register. All operations start with element 0 of the V registers and increment the element number by 1 for each successive operation.

Operands are assumed to be in floating-point format. Instructions 160, 162, 164, and 166 deliver a copy of (S_j) to the functional unit where the copy is retained as one of the operands until the completion of the operation. Therefore, S_j can be changed immediately without affecting the vector operation. The other operand is an element of V_k . For instructions 161, 163, 165, and 167, both operands are obtained from V registers.

All results are delivered to elements of V_i . If either operand is not normalized, there is no guarantee that the products will be normalized. If neither operand is normalized, the product will not be normalized.

Out-of-range conditions are described in section 4.

INSTRUCTIONS 160 - 167 (continued)

Instruction 160 forms the products of the floating-point quantity in S_j and the floating-point quantities in elements of V_k and enters the results into V_i .

Instruction 161 forms the products of the floating-point quantities in elements of V_j and V_k and enters the results into V_i .

Instruction 162 forms the half-precision rounded products of the floating-point quantity in S_j and the floating-point quantities in elements of V_k and enters the results into V_i . The low-order 19 bits of the result elements are zeroed.

Instruction 163 forms the half-precision rounded products of the floating-point quantities in elements of V_j and V_k and enters the results into V_i . The low-order 19 bits of the result elements are zeroed.

Instruction 164 forms the rounded products of the floating-point quantity in S_j and the floating-point quantities in elements of V_k and enters the results into V_i .

Instruction 165 forms the rounded products of the floating-point quantities in elements of V_j and V_k and enters the results into V_i .

Instruction 166 forms for each element, two minus the product of the floating-point quantity in S_j and the floating-point quantity in elements of V_k . It then enters the results into V_i . See the description of instruction 067 for more details.

Instruction 167 forms for each element pair, two minus the product of the floating-point quantities in elements of V_j and V_k and enters the results into V_i . See the description of instruction 067 for more details.

HOLD ISSUE CONDITIONS: V_k reserved as operand

V_i reserved as operand or result

Instruction 16x in process, unit busy
(VL) + 4 CPS[†]

[†] Vector instructions may or may not start execution immediately; they execute as data becomes available. In particular, a memory conflict that slows execution of some elements of a vector load can cause delays in all instructions in the operation chain starting with that load.

INSTRUCTIONS 160 - 167 (continued)

HOLD CONDITIONS: On mainframes equipped with Second Vector
(continued) Logical unit: instructions 140 through 145 in
process in Second Vector Logical unit. Unit
busy (VL) +4 CPs.

For instructions 160, 162, 164, and 166, S_j
reserved (except S0)

For instructions 161, 163, 165, and 167, V_j
reserved as operand

EXECUTION TIME: Instruction issue, 1 CP

V_j and V_k ready in (VL) + 3 CPs if data
available[†]

V_i ready in (VL) + 12 CPs if data
available[†]

Unit ready, (VL) + 4 CPs if data available[†]

SPECIAL CASES: $(S_j)=0$ if $j=0$.

[†] Vector instructions may or may not start execution immediately; they execute as data becomes available. In particular, a memory conflict that slows execution of some elements of a vector load can cause delays in all instructions in the operation chain starting with that load.

INSTRUCTIONS 170 - 173

CAL Syntax	Description	Octal Code
$V_i \ S_j + FV_k$	Floating-point sums of (S_j) and (V_k elements) to V_i element	170ijk
$V_i \ +FV_k^\dagger$	Transmit normalized (V_k elements) to V_i elements	170i0k
$V_i \ V_j + FV_k$	Floating-point sums of (V_j elements) and (V_k elements) to V_i elements	171ijk
$V_i \ S_j - FV_k$	Floating-point differences of (S_j) and (V_k elements) to V_i elements	172ijk
$V_i \ -FV_k^\dagger$	Transmit normalized negatives of (V_k elements) to V_i elements	172i0k
$V_i \ V_j - FV_k$	Floating-point differences of (V_j elements) and (V_k elements) to V_i elements	173ijk

Instructions 170 through 173 are executed in the Floating-point Add functional unit. Instructions 170 and 171 perform floating-point addition; instructions 172 and 173 perform floating-point subtraction. The number of additions or subtractions performed by an instruction is determined by contents of the VL register. All operations start with element 0 of the V registers and increment the element number by 1 for each operation performed. All results are delivered to V_i normalized and results are normalized even if the operands are not normalized.

Instructions 170 and 172 deliver a copy of (S_j) to the functional unit where it remains as one of the operands until the completion of the operation. The other operand is an element of V_k . For instructions 171 and 173, both operands are obtained from V registers. Out-of-range conditions are described in section 4.

HOLD ISSUE CONDITIONS: V_k reserved as operand

V_i reserved as operand or result

[†] Special CAL syntax

INSTRUCTIONS 170 - 173 (continued)

HOLD ISSUE CONDITIONS: Instructions 170 through 173 in process, unit
(continued) busy (VL) + 4 CPs[†]

For instructions 170 and 172, S_j reserved
(except S_0)

For instructions 171 and 173, V_j reserved as
operand

EXECUTION TIME: Instruction issue, 1 CP

V_j and V_k ready in (VL) + 3 CPs if data
available[†]

V_i ready in (VL) + 11 CPs if data available[†]

Unit ready, (VL) + 4 CPs if data available[†]

SPECIAL CASES: $(S_j)=0$ if $j=0$.

[†] Vector instructions may or may not start execution immediately; they execute as data becomes available. In particular, a memory conflict that slows execution of some elements of a vector load can cause delays in all instructions in the operation chain starting with that load.

INSTRUCTION 174

CAL Syntax	Description	Octal Code
V_i /HV j	Floating-point reciprocal approximation of (V_j elements) to V_i elements	174 ij 0

Instruction 174 is executed in the Reciprocal Approximation functional unit. The instruction forms an approximate value of the reciprocal of the normalized floating-point quantity in each element of V_j and enters the result into elements of V_i . The number of elements for which approximations are found is determined by the contents of the VL register.

Instruction 174 occurs in the divide sequence to compute the quotients of floating-point quantities as described in section 4 under floating-point arithmetic.

The reciprocal approximation instruction produces results of 30 significant bits. The low-order 18 bits are zeros. The number of significant bits can be extended to 48 using the reciprocal iteration instruction and a multiply.

HOLD ISSUE CONDITIONS: V_i reserved as operand or result

V_j reserved as operand

Instruction 174 in process, unit busy for
(VL) + 4 CPs[†]

EXECUTION TIME: Instruction issue, 1 CP

V_j ready in (VL) + 3 CPs if data available[†]

V_i ready in (VL) + 19 CPs if data
available[†]

Unit ready, (VL) + 4 CPs if data available[†]

SPECIAL CASES: (V_i element) is meaningless if (V_j element) is not normalized; the unit assumes that bit 2^{47} of (V_j element) is 1; no test of this bit is made.

[†] Vector instructions may or may not start execution immediately; they execute as data becomes available. In particular, a memory conflict that slows execution of some elements of a vector load can cause delays in all instructions in the operation chain starting with that load.

INSTRUCTIONS 174*i*_j1 - 174*i*_j2

CAL Syntax	Description	Octal Code
<i>V</i> _{<i>i</i>} <i>PV</i> _{<i>j</i>}	Population count of (<i>V</i> _{<i>j</i>} elements) to <i>V</i> _{<i>i</i>} elements	174 <i>i</i> _j 1
<i>V</i> _{<i>i</i>} <i>QV</i> _{<i>j</i>}	Population count parity of (<i>V</i> _{<i>j</i>} elements) to <i>V</i> _{<i>i</i>} elements	174 <i>i</i> _j 2

Instructions 174*i*_j1 and 174*i*_j2 are executed in the Vector Population/Parity functional unit, sharing some logic with the Reciprocal Approximation functional unit.

Instruction 174*i*_j1 counts the number of bits set to 1 in each element of *V*_{*j*} and enters the results into corresponding elements of *V*_{*i*}. The results are entered into the low-order 7 bits of each *V*_{*i*} element; the remaining high-order bits of each *V*_{*i*} element are zeroed.

Instruction 174*i*_j2 counts the number of bits set to 1 in each element of *V*_{*j*}. The least significant bit of each element result shows whether the result is an odd or even number. Only the least significant bit of each element is transferred to the least significant bit position of the corresponding element of register *V*_{*i*}. The remainder of the element is set to zeros. The actual population count results are not transferred.

HOLD ISSUE CONDITIONS: *V*_{*i*} reserved as operand or result

*V*_{*j*} reserved as operand

Instructions 174*xxx*1 and 174*xxx*2 in process,
unit busy for (VL) + 4 CPS[†]

Instruction 174*xxx*0 in process, unit busy for
(VL) + 9 CPS[†]

Instruction 070 in process, unit busy (070 issue
time) + 7 CPS[†]

[†] Vector instructions may or may not start execution immediately; they execute as data becomes available. In particular, a memory conflict that slows execution of some elements of a vector load can cause delays in all instructions in the operation chain starting with that load.

INSTRUCTIONS 174*ij*1 - 174*ij*2 (continued)

EXECUTION TIME: Instruction issue, 1 CP
 V_j ready in (VL) + 3 CPs if data available[†]
 V_i ready in (VL) + 10 CPs if data available[†]
 Unit ready, (VL) + 4 CPs if data available[†]

[†] Vector instructions may or may not start execution immediately; they execute as data becomes available. In particular, a memory conflict that slows execution of some elements of a vector load can cause delays in all instructions in the operation chain starting with that load.

INSTRUCTION 175

CAL Syntax	Description	Octal Code
VM V_j, Z	VM=1 when (V_j element)=0	1750j0
VM V_j, N	VM=1 when (V_j element) \neq 0	1750j1
VM V_j, P	VM=1 when (V_j element) positive, (bit $2^{63}=0$), includes (V_j element)=0	1750j2
VM V_j, M	VM=1 when (V_j element) negative, (bit $2^{63}=1$)	1750j3

Vector mask instruction 175 is executed in the Full Vector Logical functional unit.

Instruction 1750jk creates a vector mask in VM based on the results of testing the contents of the elements of register V_j . Each bit of VM corresponds to an element of V_j . Bit 2^{63} corresponds to element 0; bit 2^0 corresponds to element 63.

The type of test made by the instruction depends on the low-order 2 bits of the k designator. The high-order bit of the k designator is not used.

If the k designator is 0, the VM bit is set to 1 when (V_j element) is 0 and is set to 0 when (V_j element) is nonzero.

If the k designator is 1, the VM bit is set to 1 when (V_j element) is nonzero and is set to 0 when (V_j element) is 0.

If the k designator is 2, the VM bit is set to 1 when (V_j element) is positive and is set to 0 when (V_j element) is negative. A zero value is considered positive.

If the k designator is 3, the VM bit is set to 1 when (V_j element) is negative and is set to 0 when (V_j element) is positive. A zero value is considered positive.

The number of elements tested is determined by the contents of the VL register. VM bits corresponding to untested elements of V_j are zeroed.

Vector mask instruction 175 provide a vector counterpart to the scalar conditional branch instructions.

INSTRUCTION 175 (continued)

HOLD ISSUE CONDITIONS: V_j reserved as operand

Instruction 14x in process, unit busy
(VL) + 4 Cps[†]

Instruction 175 in process, unit busy
(VL) + 4 Cps[†]

EXECUTION TIME:

Instruction issue, 1 CP

V_j ready, (VL) + 3 Cps if data available[†]

Except for instruction 073, VM ready (VL) + 4 Cps
if data available[†]

For instruction 073, VM ready (VL) + 5 Cps if
data available[†]

SPECIAL CASES:

$k=0$ or 4, VM bit $xxx=1$ if (V_j element xxx)=0.

$k=1$ or 5, VM bit $xxx=1$ if (V_j element xxx) $\neq 0$.

$k=2$ or 6, VM bit $xxx=1$ if (V_j element xxx) is
positive; 0 is a positive condition.

$k=3$ or 7, VM bit $xxx=1$ if (V_j element xxx) is
negative.

[†] Vector instructions may or may not start execution immediately; they execute as data becomes available. In particular, a memory conflict that slows execution of some elements of a vector load can cause delays in all instructions in the operation chain starting with that load.

INSTRUCTIONS 176 - 177

CAL Syntax	Description	Octal Code
V_i ,A0,Ak	Transmit (VL) words from memory to V_i elements starting at memory address (A0) and incrementing by (Ak) for successive addresses	176i0k
V_i ,A0,1†	Transmit (VL) words from memory to V_i elements starting at memory address (A0) and incrementing by 1 for successive addresses	176i00
,A0,Ak V_j	Transmit (VL) words from V_j elements to memory starting at memory address (A0) and incrementing by (Ak) for successive addresses	1770jk
,A0,1 V_j †	Transmit (VL) words from V_j elements to memory starting at memory address (A0) and incrementing by 1 for successive addresses	1770j0

Instructions 176 and 177 transfer blocks of data between V registers and memory.

Instruction 176 transfers data from memory to elements of register V_i .

Instruction 177 transfers data from elements of register V_j to memory.

Register elements begin with 0 and are incremented by 1 for each transfer. Memory addresses begin with (A0) and are incremented by the contents of Ak. Ak contains a signed 22-bit integer which is added to the address of the current word to obtain the address of the next word. The 2 high-order bits of (Ak) are ignored. Ak can specify either a positive or negative increment allowing both forward and backward streams of reference.

The number of words transferred is determined by the contents of the VL register.

HOLD ISSUE CONDITIONS: For instruction 176 if Ports A and B busy

For instruction 177 if Port C busy

A0 reserved

† Special CAL syntax

INSTRUCTIONS 176 - 177 (continued)

HOLD ISSUE CONDITIONS: Ak reserved where $k=1$ through 7
(continued)

Scalar reference in CP1, CP2, CP3, or CP4

For instruction 176, V register i reserved as operand or result

For instruction 177, V register j reserved as operand

If not bidirectional memory mode, then instruction 176 holds on Port C busy and instruction 177 holds on Port A or B busy.

EXECUTION TIME:

For instruction 176:

Instruction issue, 1 CP

V_i ready, (VL) + 17 CPs if memory is available

Port A or B busy, (VL) + 5 CPs

For instruction 177:

Instruction issue, 1 CP

V_j ready, (VL) + 3 CPs if data is available

Port C busy, (VL) + 6 CPs

SPECIAL CASES:

Increment (A0)=1 if $k=0$.

Instruction 176 uses Port B. If Port B is busy at issue time, instruction 176 uses Port A. Instruction 177 uses Port C.

(Ak) determines the memory increment. Successive addresses are located in successive banks. References to the same bank can be made every 4 CPs or more. Incrementing (Ak) by 32 places successive memory references in the same bank, so a word is transferred every 4 CPs or more. If the address is incremented by 16, every other reference is to the same bank, and words can transfer no faster than one every 2 CPs. With any address incrementing that allows 4 CPs before addressing the same bank, the words can transfer each CP.

Memory conflict can slow loading or storing of individual vector elements. The elements are loaded or stored in order, so any delay for any element delays all succeeding elements.

SPECIAL CASES:
(continued)

For instruction 176, if there is an instruction using its destination register as a source, the execution of that instruction is delayed whenever there is a delay in instruction 176 results.

APPENDIX SECTION

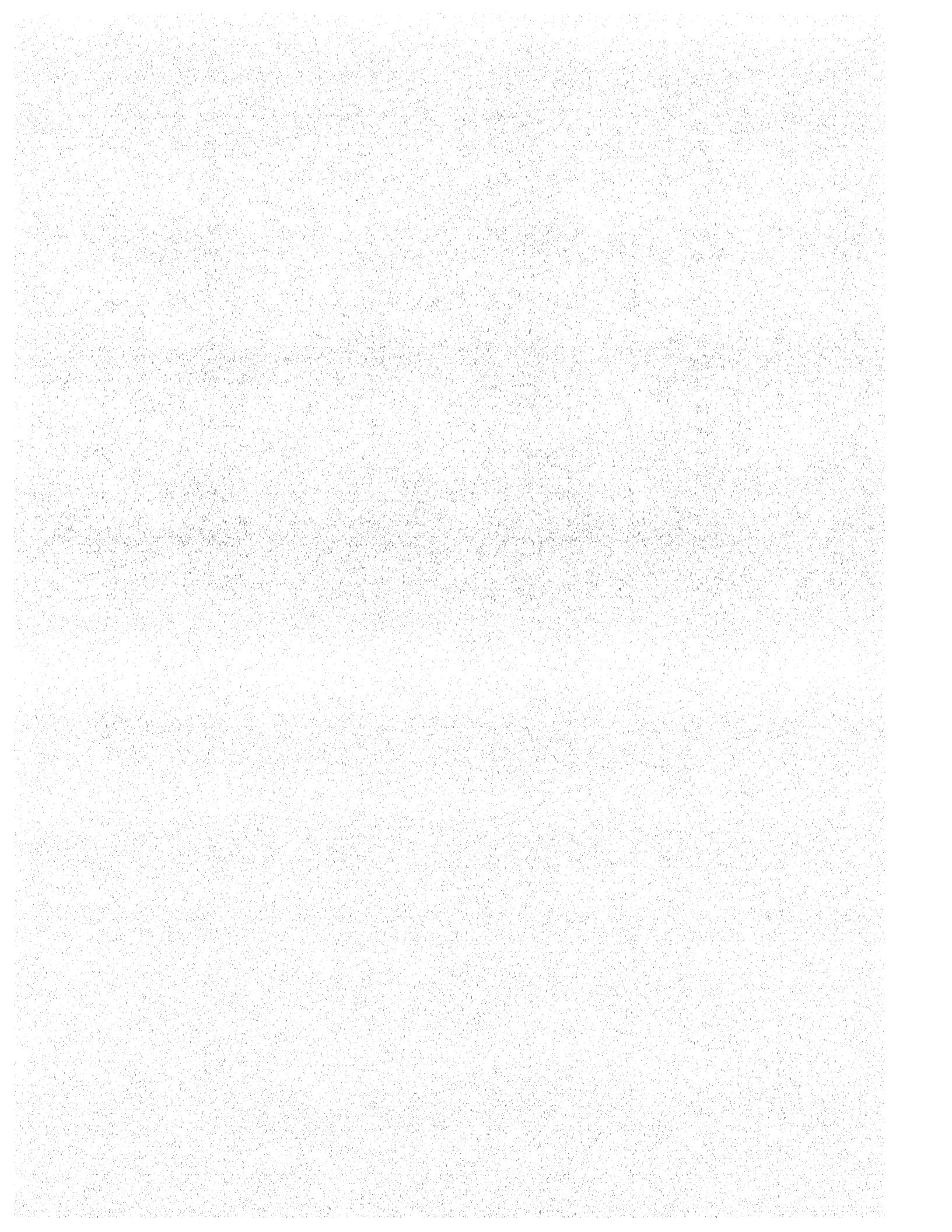

INSTRUCTION SUMMARY FOR CRAY X-MP MODELS 22 AND 24

A

<u>CRAY X-MP</u>	<u>CAL</u>	<u>UNIT</u>	<u>DESCRIPTION</u>
000000	ERR	-	Error exit
<i>††</i> 0010 <i>jk</i>	CA, <i>Aj Ak</i>	-	Set the channel (<i>Aj</i>) current address to (<i>Ak</i>) and begin the I/O sequence
<i>††</i> 0011 <i>jk</i>	CL, <i>Aj Ak</i>	-	Set the channel (<i>Aj</i>) limit address to (<i>Ak</i>)
<i>††</i> 0012 <i>j0</i>	CI, <i>Aj</i>	-	Clear Channel (<i>Aj</i>) Interrupt flag; clear device master-clear (output channel).
<i>††</i> 0012 <i>j1</i>	MC, <i>Aj</i>	-	Clear Channel (<i>Aj</i>) Interrupt flag; set device master-clear (output channel); clear device ready-held (input channel).
<i>††</i> 0013 <i>j0</i>	XA <i>Aj</i>	-	Enter XA register with (<i>Aj</i>)
<i>††</i> 0014 <i>j0</i>	RT <i>Sj</i>	-	Enter RTC register with (<i>Sj</i>)
<i>††</i> 001401	IP 1	-	Set interprocessor interrupt
<i>††</i> 001402	IP 0	-	Clear interprocessor interrupt
<i>††</i> 001403	CLN 0	-	Enter CLN register with 0
<i>††</i> 001413	CLN 1	-	Enter CLN register with 1
<i>††</i> 001423	CLN 2	-	Enter CLN register with 2
<i>††</i> 001433	CLN 3	-	Enter CLN register with 3
<i>††</i> 0014 <i>jj</i>	PCI <i>Sj</i>	-	Enter II register with (<i>Sj</i>)
<i>††</i> 001405	CCI	-	Clear PCI request
<i>††</i> 001406	ECI	-	Enable PCI request
<i>††</i> 001407	DCI	-	Disable PCI request
<i>††</i> 0015 <i>j0</i>	<i>†††</i>	-	Select performance monitor
<i>††</i> 001501	<i>†††</i>	-	Set maintenance read mode
<i>††</i> 001511	<i>†††</i>	-	Load diagnostic check byte with S1
<i>††</i> 001521	<i>†††</i>	-	Set maintenance write mode 1
<i>††</i> 001531	<i>†††</i>	-	Set maintenance write mode 2
00200 <i>k</i>	VL <i>Ak</i>	-	Transmit (<i>Ak</i>) to VL register
<i>††</i> 002000	VL 1	-	Transmit 1 to VL register
002100	EFI	-	Enable interrupt on floating-point error
002200	DFI	-	Disable interrupt on floating-point error
002300	ERI	-	Enable operand range interrupts

† Special syntax form
†† Privileged to monitor mode
††† Not supported at this time

<u>CRAY X-MP</u>	<u>CAL</u>	<u>UNIT</u>	<u>DESCRIPTION</u>
002400	DRI	-	Disable operand range interrupts
002500	DBM	-	Disable bidirectional memory transi
002600	EBM	-	Enable bidirectional memory transfe
002700	CMR	-	Complete memory references
0030j0	VM Sj	-	Transmit (Sj) to VM register
†003000	VM 0	-	Clear VM register
0034jk	SM,jk 1,TS	-	Test & set semaphore jk in SM
0036jk	SM,jk 0	-	Clear semaphore jk in SM
0037jk	SM,jk 1	-	Set semaphore jk in SM
004000	EX	-	Normal exit
0050jk	J Bjk	-	Jump to (Bjk)
006i.jkm	J exp	-	Jump to exp
007i.jkm	R exp	-	Return jump to exp; set B00 to P.
010i.jkm	JAZ exp	-	Branch to exp if (A0)=0 (i ₂ =0)
011i.jkm	JAN exp	-	Branch to exp if (A0)≠0 (i ₂ =0)
012i.jkm	JAP exp	-	Branch to exp if (A0) positive; 0 is positive (i ₂ =0).
013i.jkm	JAM exp	-	Branch to exp if (A0) negative (i ₂ =0)
014i.jkm	JSZ exp	-	Branch to exp if (S0)=0 (i ₂ =0)
015i.jkm	JSN exp	-	Branch to exp if (S0)≠0 (i ₂ =0)
016i.jkm	JSP exp	-	Branch to exp if (S0) positive; 0 is positive (i ₂ =0).
017i.jkm	JSM exp	-	Branch to exp if (S0) negative (i ₂ =0)
020i.jkm	Ai exp	-	Transmit exp=jkm to Ai
021i.jkm	Ai exp	-	Transmit exp=ones complement of jkm to Ai
022i.jk	Ai exp	-	Transmit exp=jk to Ai
023i.j0	Ai Sj	-	Transmit (Sj) to Ai
023i01	Ai VL	-	Transmit (VL) to Ai
024i.jk	Ai Bjk	-	Transmit (Bjk) to Ai
025i.jk	Bjk Ai	-	Transmit (Ai) to Bjk
026i.j0	Ai PSj	Pop/LZ	Population count of (Sj) to Ai
026i.j1	Ai QSj	Pop/LZ	Population count parity of (Sj) to Ai
026i.j7	Ai SBj	-	Transmit (SBj) to Ai
027i.j0	Ai ZSj	Pop/LZ	Leading zero count of (Sj) to Ai
027i.j7	SBj Ai	-	Transmit (Ai) to SBj
030i.jk	Ai Aj+Ak	A Int Add	Integer sum of (Aj) and (Ak) to Ai
†030i0k	Ai Ak	A Int Add	Transmit (Ak) to Ai
†030i.j0	Ai Aj+1	A Int Add	Integer sum of (Aj) and 1 to Ai
031i.jk	Ai Aj-Ak	A Int Add	Integer difference of (Aj) less (Ak) to Ai

† Special syntax form

<u>CRAY X-MP</u>	<u>CAL</u>	<u>UNIT</u>	<u>DESCRIPTION</u>
†031i00	Ai -1	A Int Add	Transmit -1 to Ai
†031i0k	Ai -Ak	A Int Add	Transmit the negative of (Ak) to Ai
†031ij0	Ai Aj-1	A Int Add	Integer difference of (Aj) less 1 to Ai
032ijk	Ai Aj*Ak	A Int Mult	Integer product of (Aj) and (Ak) to Ai
033i00	Ai CI	-	Channel number to Ai (j=0)
033ij0	Ai CA,Aj	-	Address of channel (Aj) to Ai (j≠0; k=0)
033ij1	Ai CE,Aj	-	Error flag of channel (Aj) to Ai (j≠0; k=1)
034ijk	Bjk,Ai ,A0	Memory	Read (Ai) words to B register jk from (A0)
†034ijk	Bjk,Ai 0,A0	Memory	Read (Ai) words to B register jk from (A0)
035ijk	,A0 Bjk,Ai	Memory	Store (Ai) words at B register jk to (A0)
†035ijk	0,A0 Bjk,Ai	Memory	Store (Ai) words at B register jk to (A0)
036ijk	Tjk,Ai ,A0	Memory	Read (Ai) words to T register jk from (A0)
†036ijk	Tjk,Ai 0,A0	Memory	Read (Ai) words to T register jk from (A0)
037ijk	,A0 Tjk,Ai	Memory	Store (Ai) words at T register jk to (A0)
†037ijk	0,A0 Tjk,Ai	Memory	Store (Ai) words at T register jk to (A0)
040ijkm	Si exp	-	Transmit jkm to Si
041ijkm	Si exp	-	Transmit exp=ones complement of jkm to Si
042ijk	Si <exp	S Logical	Form ones mask exp bits in Si from the right; jk field gets 64-exp.
†042ijk	Si #>exp	S Logical	Form zeros mask exp bits in Si from the left; jk field gets 64-exp.
†042i77	Si 1	S Logical	Enter 1 into Si
†042i00	Si -1	S Logical	Enter -1 into Si
043ijk	Si >exp	S Logical	Form ones mask exp bits in Si from the left; jk field gets exp.
†043ijk	Si #<exp	S Logical	Form zeros mask exp bits in Si from the right; jk field gets 64-exp.
†043i00	Si 0	S Logical	Clear Si
044ijk	Si Sj&Sk	S Logical	Logical product of (Sj) and (Sk) to Si

† Special syntax form

<u>CRAY X-MP</u>	<u>CAL</u>	<u>UNIT</u>	<u>DESCRIPTION</u>
†044ij0	$S_i S_j \& SB$	S Logical	Sign bit of (Sj) to Si
†044ij0	$S_i SB \& S_j$	S Logical	Sign bit of (Sj) to Si (j≠0)
045ijk	$S_i \#S_k \& S_j$	S Logical	Logical product of (Sj) and ones complement of (Sk) to Si
†045ij0	$S_i \#SB \& S_j$	S Logical	(Sj) with sign bit cleared to Si
046ijk	$S_i S_j \setminus S_k$	S Logical	Logical difference of (Sj) and (Sk) to Si
†046ij0	$S_i S_j \setminus SB$	S Logical	Toggle sign bit of Sj, then enter into Si
†046ij0	$S_i SB \setminus S_j$	S Logical	Toggle sign bit of Sj, then enter into Si (j≠0)
047ijk	$S_i \#S_j \setminus S_k$	S Logical	Logical equivalence of (Sk) and (Sj) to Si
†047i0k	$S_i \#S_k$	S Logical	Transmit ones complement of (Sk) to Si
†047ij0	$S_i \#S_j \setminus SB$	S Logical	Logical equivalence of (Sj) and sign bit to Si
†047ij0	$S_i \#SB \setminus S_j$	S Logical	Logical equivalence of (Sj) and sign bit to Si (j≠0)
†047i00	$S_i \#SB$	S Logical	Enter ones complement of sign bit into Si
050ijk	$S_i S_j ! S_i \& S_k$	S Logical	Logical product of (Si) and (Sk) complement ORed with logical product of (Sj) and (Sk) to Si
†050ij0	$S_i S_j ! S_i \& SB$	S Logical	Scalar merge of (Si) and sign bit of (Sj) to Si
051ijk	$S_i S_j ! S_k$	S Logical	Logical sum of (Sj) and (Sk) to Si
†051i0k	$S_i S_k$	S Logical	Transmit (Sk) to Si
†051ij0	$S_i S_j ! SB$	S Logical	Logical sum of (Sj) and sign bit to Si
†051ij0	$S_i SB ! S_j$	S Logical	Logical sum of (Sj) and sign bit to Si (j≠0)
†051i00	$S_i SB$	S Logical	Enter sign bit into Si
052ijk	$S_0 S_i < exp$	S Shift	Shift (Si) left exp=jk places to S0
053ijk	$S_0 S_i > exp$	S Shift	Shift (Si) right exp=64-jk places to S0
054ijk	$S_i S_i < exp$	S Shift	Shift (Si) left exp=jk places
055ijk	$S_i S_i > exp$	S Shift	Shift (Si) right exp=64-jk places
056ijk	$S_i S_i, S_j < A_k$	S Shift	Shift (Si and Sj) left (Ak) places to Si
†056ij0	$S_i S_i, S_j < 1$	S Shift	Shift (Si and Sj) left one place to Si

† Special syntax form

<u>CRAY X-MP</u>	<u>CAL</u>	<u>UNIT</u>	<u>DESCRIPTION</u>
†056i0k	Si Si<Ak	S Shift	Shift (Si) left (Ak) places to Si
057ijk	Si Sj,Si>Ak	S Shift	Shift (Sj and Si) right (Ak) places to Si
†057ijo	Si Sj,Si>1	S Shift	Shift (Sj and Si) right one place to Si
†057i0k	Si Si>Ak	S Shift	Shift (Si) right (Ak) places to Si
060ijk	Si Sj+S _k	S Int Add	Integer sum of (Sj) and (Sk) to Si
061ijk	Si Sj-S _k	S Int Add	Integer difference of (Sj) and (Sk) to Si
†061i0k	Si -S _k	S Int Add	Transmit negative of (Sk) to Si
062ijk	Si Sj+FS _k	Fp Add	Floating-point sum of (Sj) and (Sk) to Si
†062i0k	Si +FS _k	Fp Add	Normalize (Sk) to Si
063ijk	Si Sj-FS _k	Fp Add	Floating-point difference of (Sj) and (Sk) to Si
†063i0k	Si -FS _k	Fp Add	Transmit normalized negative of (Sk) to Si
064ijk	Si Sj*FS _k	Fp Mult	Floating-point product of (Sj) and (Sk) to Si
065ijk	Si Sj*HS _k	Fp Mult	Half-precision rounded floating-point product of (Sj) and (Sk) to Si
066ijk	Si Sj*RS _k	Fp Mult	Full-precision rounded floating-point product of (Sj) and (Sk) to Si
067ijk	Si Sj*IS _k	Fp Mult	2-floating-point product of (Sj) and (Sk) to Si
070ijo	Si /HS _j	Fp Rcpl	Floating-point reciprocal approximation of (Sj) to Si
071i0k	Si Ak	-	Transmit (Ak) to Si with no sign extension
071i1k	Si +Ak	-	Transmit (Ak) to Si with sign extension
071i2k	Si +FA _k	-	Transmit (Ak) to Si as unnormalized floating-point number
071i30	Si 0.6	-	Transmit constant 0.75*2**48 to Si
071i40	Si 0.4	-	Transmit constant 0.5 to Si
071i50	Si 1.	-	Transmit constant 1.0 to Si
071i60	Si 2.	-	Transmit constant 2.0 to Si

† Special syntax form

<u>CRAY X-MP</u>	<u>CAL</u>	<u>UNIT</u>	<u>DESCRIPTION</u>
071i70	Si 4.	-	Transmit constant 4.0 to Si
072i00	Si RT	-	Transmit (RTC) to Si
072i02	Si SM	-	Transmit (SM) to Si
072ij3	Si STj	-	Transmit (STj) to Si
073i00	Si VM	-	Transmit (VM) to Si
073i11	††	-	Read performance counter into Si
073i21	††	-	Increment performance counter (maintenance)
073i31	††	-	Clear all maintenance modes
073ij1	Si SRj	-	Transmit (SRj) to Si (j=0)
073i02	SM Si	-	Transmit (Si) to SM
073ij3	STj Si	-	Transmit (Si) to STj
074ijk	Si Tjk	-	Transmit (Tjk) to Si
075ijk	Tjk Si	-	Transmit (Si) to Tjk
076ijk	Si Vj,Ak	-	Transmit (Vj, element (Ak)) to Si
077ijk	Vi,Ak Sj	-	Transmit (Sj) to Vi element (Ak)
†077i0k	Vi,Ak 0	-	Clear Vi element (Ak)
10hijkm	Ai exp,Ah	Memory	Read from ((Ah)+exp) to Ai (A0=0)
†100ijkm	Ai exp,0	Memory	Read from (exp) to Ai
†100ijkm	Ai exp,	Memory	Read from (exp) to Ai
†10hi00 0	Ai ,Ah	Memory	Read from (Ah) to Ai
11hijkm	exp,Ah Ai	Memory	Store (Ai) to (Ah)+exp (A0=0)
†110ijkm	exp,0 Ai	Memory	Store (Ai) to exp
†110ijkm	exp, Ai	Memory	Store (Ai) to exp
†11hi00 0	,Ah Ai	Memory	Store (Ai) to (Ah)
12hijkm	Si exp,Ah	Memory	Read from ((Ah)+exp) to Si (A0=0)
†120ijkm	Si exp,0	Memory	Read from exp to Si
†120ijkm	Si exp,	Memory	Read from exp to Si
†12hi00 0	Si ,Ah	Memory	Read from (Ah) to Si
13hijkm	exp,Ah Si	Memory	Store (Si) to (Ah)+exp (A0=0)
†130ijkm	exp,0 Si	Memory	Store (Si) to exp
†130ijkm	exp, Si	Memory	Store (Si) to exp
†13hi00 0	,Ah Si	Memory	Store (Si) to (Ah)
140ijk	Vi Sj&Vk	V Logical	Logical products of (Sj) and (Vk) to Vi
141ijk	Vi Vj&Vk	V Logical	Logical products of (Vj) and (Vk) to Vi
142ijk	Vi Sj!Vk	V Logical	Logical sums of (Sj) and (Vk) to Vi
†142i0k	Vi Vk	V Logical	Transmit (Vk) to Vi
143ijk	Vi Vj!Vk	V Logical	Logical sums of (Vj) and (Vk) to Vi
144ijk	Vi Sj\Vk	V Logical	Logical differences of (Sj) and (Vk) to Vi

† Special syntax form

†† Not supported at this time

<u>CRAY X-MP</u>	<u>CAL</u>	<u>UNIT</u>	<u>DESCRIPTION</u>
145ijk	$V_i \ V_j \setminus V_k$	V Logical	Logical differences of (V_j) and (V_k) to V_i
†145iii	$V_i \ 0$	V Logical	Clear V_i
146ijk	$V_i \ S_j!V_k\&VM$	V Logical	Transmit (S_j) if VM bit=1; (V_k) if VM bit=0 to V_i .
†146i0k	$V_i \ \#VM\&V_k$	V Logical	Vector merge of (V_k) and 0 to V_i
147ijk	$V_i \ V_j!V_k\&VM$	V Logical	Transmit (V_j) if VM bit=1; (V_k) if VM bit=0 to V_i .
150ijk	$V_i \ V_j<A_k$	V Shift	Shift (V_j) left (A_k) places to V_i
†150ij0	$V_i \ V_j<1$	V Shift	Shift (V_j) left one place to V_i
151ijk	$V_i \ V_j>A_k$	V Shift	Shift (V_j) right (A_k) places to V_i
†151ij0	$V_i \ V_j>1$	V Shift	Shift (V_j) right one place to V_i
152ijk	$V_i \ V_j, V_j<A_k$	V Shift	Double shift (V_j) left (A_k) places to V_i
†152ij0	$V_i \ V_j, V_j<1$	V Shift	Double shift (V_j) left one place to V_i
153ijk	$V_i \ V_j, V_j>A_k$	V Shift	Double shift (V_j) right (A_k) places to V_i
†153ij0	$V_i \ V_j, V_j>1$	V Shift	Double Shift (V_j) right one place to V_i
154ijk	$V_i \ S_j+V_k$	V Int Add	Integer sums of (S_j) and (V_k) to V_i
155ijk	$V_i \ V_j+V_k$	V Int Add	Integer sums of (V_j) and (V_k) to V_i
156ijk	$V_i \ S_j-V_k$	V Int Add	Integer differences of (S_j) and (V_k) to V_i
†156i0k	$V_i \ -V_k$	V Int Add	Transmit negative of (V_k) to V_i
157ijk	$V_i \ V_j-V_k$	V Int Add	Integer differences of (V_j) and (V_k) to V_i
160ijk	$V_i \ S_j*FV_k$	Fp Mult	Floating-point products of (S_j) and (V_k) to V_i
161ijk	$V_i \ V_j*FV_k$	Fp Mult	Floating-point products of (V_j) and (V_k) to V_i
162ijk	$V_i \ S_j*HV_k$	Fp Mult	Half-precision rounded floating-point products of (S_j) and (V_k) to V_i
163ijk	$V_i \ V_j*HV_k$	Fp Mult	Half-precision rounded floating-point products of (V_j) and (V_k) to V_i
164ijk	$V_i \ S_j*RV_k$	Fp Mult	Rounded floating-point products of (S_j) and (V_k) to V_i

† Special syntax form

<u>CRAY X-MP</u>	<u>CAL</u>	<u>UNIT</u>	<u>DESCRIPTION</u>
165ijk	Vi Vj*RVk	Fp Mult	Rounded floating-point products of (Vj) and (Vk) to Vi
166ijk	Vi Sj*IVk	Fp Mult	2-floating-point products of (Sj) and (Vk) to Vi
167ijk	Vi Vj*IVk	Fp Mult	2-floating-point products of (Vj) and (Vk) to Vi
170ijk	Vi Sj+FVk	Fp Add	Floating-point sums of (Sj) and (Vk) to Vi
†170i0k	Vi +FVk	Fp Add	Normalize (Vk) to Vi
171ijk	Vi Vj+FVk	Fp Add	Floating-point sums of (Vj) and (Vk) to Vi
172ijk	Vi Sj-FVk	Fp Add	Floating-point differences of (Sj) and (Vk) to Vi
†172i0k	Vi -FVk	Fp Add	Transmit normalized negatives of (Vk) to Vi
173ijk	Vi Vj-FVk	Fp Add	Floating-point differences of (Vj) and (Vk) to Vi
174ij0	Vi /HVj	Fp Rcpl	Floating-point reciprocal approximations of (Vj) to Vi
174ij1	Vi PVj	V Pop	Population counts of (Vj) to Vi
174ij2	Vi QVj	V Pop	Population count parities of (Vj) to Vi
1750j0	VM Vj,Z	V Logical	VM=1 where (Vj)=0
1750j1	VM Vj,N	V Logical	VM=1 where (Vj)≠0
1750j2	VM Vj,P	V Logical	VM=1 if (Vj) positive; 0 is positive.
1750j3	VM Vj,M	V Logical	VM=1 if (Vj) negative
176i0k	Vi ,A0,Ak	Memory	Read (VL) words to Vi from (A0) incremented by (Ak)
†176i00	Vi ,A0,1	Memory	Read (VL) words to Vi from (A0) incremented by 1
1770jk	,A0,Ak Vj	Memory	Store (VL) words from Vj to (A0) incremented by (Ak)
†1770j0	,A0,1 Vj	Memory	Store (VL) words from Vj to (A0) incremented by 1

† Special syntax form

6 MBYTE PER SECOND CHANNEL DESCRIPTIONS

B

INTRODUCTION

Each input or output 6 Mbyte per second channel directly accesses Central Memory. Input channels store external data in memory and output channels read data from memory. A primary task of a channel is to convert 64-bit Central Memory words into 16-bit parcels or 16-bit parcels into 64-bit Central Memory words. Four parcels make up one Central Memory word with bits of the parcels assigned to memory bit positions (see section 2 of this publication).

Each input or output channel has a data channel (4 parity bits, 16 data bits, and 3 control lines), a 64-bit assembly or disassembly register, a channel Current Address (CA) register, and a channel Limit Address (CL) register.

Three control signals (Ready, Resume, and Disconnect) coordinate the transfer of parcels over the channels. In addition to the three control signals, the output channel of the pair has a Master Clear line.

This appendix describes the signal sequence of a 6 Mytes per second input channel and an output channel.

6 MBYTE PER SECOND INPUT CHANNEL SIGNAL SEQUENCE

A general view of a 6 Mbyte per second input channel signal sequence is illustrated in table B-1. The data bits, parity bits, and each signal in the sequence are described below.

DATA BITS 2^0 THROUGH 2^{15}

Data bits 2^0 , 2^1 , ..., 2^{15} are signals carrying the 16-bit parcel of data from the external device to Central Memory. The data bits must all be valid within 25 nanoseconds after the leading edge of the Ready signal. Data bit signals must remain unchanged on the lines until the corresponding Resume signal is received by the external device. Normally, data is sent coincidentally with the Ready signal and is held until the subsequent Ready signal.

Table B-1. Input channel signal exchange

Central Memory	Channel	External Equipment
1. Activate channel (set CL and CA).		
2. †	←	Data $2^{63} - 2^{48}$ with Ready
3. Resume	→	
4.	←	Data $2^{47} - 2^{32}$ with Ready
5. Resume	→	
6.	←	Data $2^{31} - 2^{16}$ with Ready
7. Resume	→	
8.	←	Data $2^{15} - 2^0$ with Ready
9. Write word to memory and advance current address.		
10a. Resume	→	
10b. If (CA)=(CL), go to 13.		
11.		If more data, go to 2.
12.	←	Disconnect (ignored if CA=CL or if channel not active).
13. Set interrupt and deactivate channel.		

† Step 2 can initially precede step 1; that is, the first parcel and ready signal can arrive before requested.

PARITY BITS 0 THROUGH 3

Parity bits 0, 1, 2, and 3 are each assigned to a 4-bit group of data bits. The parity bits are set or cleared to give the bit group odd parity. Bit assignments follow.

<u>Parity bit</u>	<u>Data bits</u>
0	$2^0 - 2^3$
1	$2^4 - 2^7$
2	$2^8 - 2^{11}$
3	$2^{12} - 2^{15}$

Parity bits are sent from the external device to Central Memory at the same time as data bits and are held stable in the same way as the data bits.

READY SIGNAL

The Ready signal sent to Central Memory indicates a parcel of data is being sent to the Central Memory input channel and can be sampled. A Ready signal is a pulse 50 \pm 10 nanoseconds wide (at 50% voltage points). The leading edge of the Ready signal at Central Memory begins the timing for sampling the data bits.

RESUME SIGNAL

The Resume signal is sent from Central Memory to the external device showing the parcel was received and Central Memory is ready for the next data transmission. A Resume signal is a pulse 50 \pm 8 nanoseconds wide (at 50% voltage points).

DISCONNECT SIGNAL

The Disconnect signal is sent from the external device to Central Memory and indicates transmission from the external device is complete. The Disconnect signal is sent after the Resume signal is received for the last Ready signal. A Disconnect signal is a pulse 50 \pm 10 nanoseconds wide (at the 50% voltage points).

6 MBYTE PER SECOND OUTPUT CHANNEL SIGNAL SEQUENCE

A general view of a 6 Mbyte per second output channel signal sequence is illustrated in table B-2. The data bits, parity bits, and each signal in the sequence are described following the table.

Table B-2. Output channel signal exchange

Central Memory	Channel	External Equipment
1. Activate channel (set CL and CA).		
2. Read word from memory and advance current address.		
3. Data $2^{63} - 2^{48}$ with Ready	→	
4.	←	Resume
5. Data $2^{47} - 2^{32}$ with Ready	→	
6.	←	Resume
7. Data $2^{31} - 2^{16}$ with Ready	→	
8.	←	Resume
9. Data $2^{15} - 2^0$ with Ready	→	
10.	←	Resume
11. If $(CA) \neq (CL)$, go to 2.		
12. Disconnect.	→	
13. Set interrupt and deactivate channel.		

DATA BITS 2^0 THROUGH 2^{15}

Data bits $2^0, 2^1, \dots, 2^{15}$ are signals carrying a 16-bit parcel of data from Central Memory to an external device. The data bits are sent concurrently within 5 nanoseconds of the leading edge of the Ready signal. Data bit signals remain steady on the lines until the Resume signal is received.

PARITY BITS 0 THROUGH 3

Parity bits 0, 1, 2, and 3 are each assigned to a 4-bit group of data bits. The parity bits are set or cleared to give the bit group odd parity. Bit assignments follow:

<u>Parity bit</u>	<u>Data bits</u>
0	$2^0 - 2^3$
1	$2^4 - 2^7$
2	$2^8 - 2^{11}$
3	$2^{12} - 2^{15}$

Parity bits are sent from Central Memory to the external device at the same time as the data bits and are held stable in the same way as the data bits.

READY SIGNAL

The Ready signal sent from Central Memory to the external device indicates data is present and can be sampled. A Ready signal is a pulse 50 ± 8 nanoseconds wide (at 50% voltage points). The leading edge of the Ready signal can be used to time data sampling in the external device.

RESUME SIGNAL

The Resume signal is sent from the external device to Central Memory showing the parcel was received and the external device is ready for the next parcel transmission. A Resume signal is a pulse 50 ± 10 nanoseconds wide (at 50% voltage points).

DISCONNECT SIGNAL

The Disconnect signal is sent from Central Memory to the external device and indicates transmission from Central Memory is complete. The Disconnect signal is sent after Central Memory receives the Resume signal from the last Ready signal. A Disconnect signal is a pulse 50 ± 8 nanoseconds wide (at 50% voltage points).

PERFORMANCE MONITOR

C

INTRODUCTION

The system contains a set of eight performance counters to track certain hardware related events that can be used to indicate relative performance. The events that can be tracked are the number of specific instructions issued, hold issue conditions, the number of fetches, references, etc. and are selected through instruction 0015*j*0. Table C-1 lists all operations that can be monitored.

Performance monitoring instructions allow you to select specific hardware related events for monitoring, read the results of the performance monitors into a scalar register, and test the operation of the performance counters.

The instructions used for performance monitoring are:

- 0015*j*0 Select performance monitor
- 073*i*11 Read performance counter into *S_i*
- 073*i*21 Increment performance counter (maintenance)

All instructions are executed in monitor mode.

SELECTING PERFORMANCE EVENTS

Instruction 0015*j*0 selects for monitoring one of the four groups of hardware related events shown in table C-1 and clears all performance monitors. The low-order 2 bits of the *j* field selects the group.

During each CP in non-monitor (user) mode, the performance counters advance their totals according to the number of monitored events that occur. Each of the performance counters can increment at a maximum rate of +3 per CP. This allows a counter to continuously monitor for approximately 62 hours before it is reset.

Performance events are monitored only while operating in user (non-monitor) mode. Entering monitor mode disables advancing of the performance counters.

Table C-1. Performance counter group descriptions

Monitor Function	Performance Counter	Description	Increment Per CP
<i>j=0</i>	0	Number of: Instructions issued	+1
	1	CPS holding issue	+1
	2	Fetches	+1
	3	I/O references	+1
	4	CPU references	+3 max
	5	Floating-point add operations	+1
	6	Floating-point multiply operations	+1
	7	Floating-point reciprocal operations	+1
<i>j=1</i>	0	Hold issue conditions: Semaphores	+1
	1	Shared registers	+1
	2	A registers	+1
	3	S registers	+1
	4	V registers	+1
	5	V functional units	+1
	6	Scalar memory	+1
	7	Block memory	+1
<i>j=2</i>	0	Number of: Fetches	+1
	1	Scalar references	+1
	2	Scalar conflicts	+1
	3	I/O references	+1
	4	I/O conflicts	+1
	5	Block references	+3 max
	6	Block conflicts	+3 max
	7	Vector memory references	+3 max
<i>j=3</i>	0	Number of: 000 - 017 instructions	+1
	1	020 - 137 instructions	+1
	2	140 - 157, 175 instructions	+1
	3	160 - 174 instructions	+1
	4	176, 177 instructions	+1
	5	Vector integer operations	+3 max
	6	Vector floating point operations	+3 max
	7	Vector memory references	+3 max

READING PERFORMANCE RESULTS

Performance counter totals can be read using instruction 073i11, which transmits either the high-order or low-order bits of a performance counter to the high-order bits of scalar register S_i according to the contents of the performance counter pointer.

Entering monitor mode disables advancing of all performance counters and clears the performance counter pointer. The first execution of a 073i11 instruction reads the low-order bits of counter 0 into S_i and increments the performance counter pointer. The second 073i11 instruction reads the high-order bits of counter 0 into S_i and again increments the pointer. After each 073i11 instruction, the performance counter pointer is advanced by 1. Even values of the pointer select the low-order bits of a performance counter to be read into S_i ; odd values of the pointer select the high-order bits of the performance counter to be read.

Low-order bits 0 through 25 of the performance counter are read into bits 32 through 57 of S_i . High-order bits 26 through 45 of the performance counter are read into bits 38 through 57 of S_i .

A sequence for reading a set of performance counters appears as follows (there must be a 2 CP delay between sequential 073i11 instructions):

073i11	Low-order bits of counter 0 to S_i
2 CP delay	
073i11	High-order bits of counter 1 to S_i
2 CP delay	
073i11	Low-order bits of counter 1 to S_i
2 CP delay	
073i11	High-order bits of counter 2 to S_i
2 CP delay	
.	.
.	.
.	.

TESTING PERFORMANCE COUNTERS

Instruction 073i21 is used to test the operation of the performance counters by incrementing the value stored in the counter while in monitor mode.

Entering monitor mode disables advancing of all performance counters by user programs and clears the performance counter pointer. This pointer determines which performance counter, and which bits in that counter, will be incremented. Even values of the pointer increment bits 0 and 6

of the performance counter when instruction 073i21 is executed, odd values of the pointer increment bit 26. The pointer is advanced from even to odd and to the next counter through instruction 073i11.

There must be a 1 CP delay between sequential 073i21 instructions.

Execution of instruction 073i21 loads register Si with all ones as a side effect of the basic 073 instruction.

SECDED MAINTENANCE MONITOR

D

INTRODUCTION

Modules involved with generating and interpreting the 8-bit check byte used for SECDED include logic that can be used for verifying check bit storage, check bit generation, and error detection and correction.

The instructions used for these maintenance mode functions are:

001501 Set maintenance read mode
001511 Load diagnostic check byte with S1
001521 Set maintenance write mode 1
001531 Set maintenance write mode 2
073i31 Clear all maintenance modes

These instructions are all executed in monitor mode, and for instructions 0015xx, the maintenance mode switch (located on the mainframe's control panel) must be on or the instructions become no-ops.

VERIFICATION OF CHECK BIT STORAGE

To verify the storage ability of the SECDED check bits without moving memory modules, two instructions are used: 001501 and 001521.

The maintenance write mode 1 instruction, 001521, replaces the 8 check bits generated by the SECDED circuitry with specific bits of a data word as it is written into memory. The maintenance read mode instruction, 001501, complements the write instruction by replacing the same bits of a data word with the 8 check bits as it is read from memory.

By using the instructions together (and with error correction disabled through the switch on the mainframe's control panel), specified bits of a data word are stored and read back through the check bit storage paths and verification of SECDED check bit storage operation is accomplished.

Instruction 001521, maintenance write mode 1, and 001501, maintenance read mode, replace data bits with check bits and vice versa as shown below.

<u>Data bit</u>		<u>Check bit</u>
46		0
47		1
62		2
63	Read----->	3
14	<-----Write	4
15		5
30		6
31		7

VERIFICATION OF CHECK BIT GENERATION

The maintenance read mode instruction, 001501, is used to verify the correct generation of SECDED check bits for a word of data.

When the instruction is executed, the 8 check bits for SECDED replace specific data bits as the word is read into memory, as shown above. A test program can easily extract these check bits and verify their correctness, thus checking the accuracy of the SECDED check bit circuitry.

Since the CPU replaces the data bits with check bits on all reads to memory until instruction 073131 is executed (including fetch, scalar and vector reads, and I/O for the CPU), the test program should initially rewrite all of memory using the 001501 instruction to set up the SECDED check bits for a subsequent read by fetch or I/O.

Error correction must be disabled during this test.

VERIFICATION OF ERROR DETECTION AND CORRECTION

The maintenance write mode 2 instruction, 001531, and the load diagnostic check byte with S1 instruction, 001511, are used to verify operation of the SECDED circuitry.

To verify operation, a diagnostic check byte is initially loaded with the high-order bits of register S1 through instruction 001511 as shown below:

<u>S1 bit</u>	<u>Diagnostic check bit</u>
56	0
57	1
58	2
59	3
60	4
61	5
62	6
63	7

This diagnostic check byte is then written into memory in place of the normal SECDED check bits on any subsequent CPU write to memory (writes from I/O through this CPU are not affected). With error correction enabled (through the switch on the mainframe's control panel), a subsequent read of the memory location allows different paths within the error detection and correction circuitry to be checked out.

The diagnostic check byte retains its value until a new one is entered.

CLEARING MAINTENANCE MODE FUNTIONS

Instruction 073i31, clear all maintenance modes, clears the following maintenance mode instructions:

- 001501 Set maintenance read mode
- 001521 Set maintenance write mode 1
- 001531 Set maintenance write mode 2

A Master Clear also clears the instructions.

As a side effect of the 073i31 instruction, Si is loaded with all ones.

INDEX

100

INDEX

- 1-Parcel instruction format
 - with combined j and k fields, 5-2
 - with discrete j and k fields, 5-1
- 100 Mbyte per second channel, 2-16
- 1250 Mbyte channel, 2-14
- 16-bank phasing, 2-8
- 2-Parcel instruction format
 - with combined i, j, k, and m fields, 5-3
 - with combined j, k, and m fields, 5-2
- 6 Mbyte per second channels, 2-16, B-1
 - I/O interrupts, 2-18
 - I/O program flowchart, 2-19
 - data bits, B-1
 - descriptions, B-1
 - input channel error conditions, 2-20
 - input channel programming, 2-19
 - input signal sequence, B-1
 - instructions, 2-16
 - multi-CPU programming, 2-17
 - operation, 2-18
 - output channel programming, 2-20
 - output signal sequence, B-3
 - word assembly/disassembly, 2-18
- 8-bit status register, 4-8
- A registers, see Address registers
- Access conflicts, shared registers, 2-13
- Access priorities for memory, 2-7
- Access time, memory, 2-1
- Active exchange package, 3-13
- Addition algorithm, 4-27
- Addition, floating-point, 4-28
- Address Add functional unit, 4-15
- Address assembly, 2-3
- Address functional units, 4-14
- Address Multiply functional unit, 4-15
- Address processing, 4-1
- Address registers, 4-3
- Addressing, memory, 2-3, 2-4
- Algorithm
 - addition, 4-27
 - derivation of division, 4-31
 - division, 4-22
 - multiplication, 4-28
- AND function, 4-35
- Arithmetic operations 4-21
- Auxiliary I/O processor (XIOP), 1-9

- B registers, see Intermediate registers
- Beginning address registers, 3-3
- Bank phasing, 2-2, 2-8
- Bidirectional Memory Mode flag, 3-10
- Bidirectional memory references, 2-5

- Block reads and writes, concurrent, 2-5
- Block transfer references, 2-5
- Branching within buffers, 3-4
- Buffer I/O processor (BIOP), 1-9
- Buffers, instruction, 3-3

- CA register, see Current Address register
- Central Memory
 - access, 2-4
 - access priorities, 2-7
 - access time, 2-1
 - addressing 12-column mainframe, 2-4
 - addressing, 6-column mainframe, 2-3
 - banks, 2-1
 - cycle time, 2-1
 - error correction, 2-8
 - I/O access priority, 2-7
 - inter-CPU access priority, 2-7
 - organization, 2-2
 - ports, 2-4
 - reference, 2-6
 - size, 1-1
 - transfer rates, 2-1
 - word size, 2-1
- Central Processing Unit
 - computation section characteristics, 4-2
 - control and data paths, 1-6
 - input/output section, 2-14
 - instruction format, 5-1
 - instructions, 5-1
 - overview, 1-5
 - shared resources, 2-1
 - speed, 1-3
- Channel
 - 100 Mbyte per second, 2-16, B-1
 - 1250 Mbyte, 2-14
 - 6 Mbyte per second, 2-16
 - features, 2-15
 - groups, 2-24
 - I/O control, 2-22
 - input/output data paths, 2-23
 - numbers, 2-24
 - types, 2-14
- Channel Limit register (CL), 2-16
- Channels for I/O, 2-6
- Characteristics of system, 1-3
- Check bits, 2-9
- CIP register, see Current Instruction Parcel register
- CL register, See Channel Limit register
- Clear programmable clock interrupt request, 3-20

CLN register, see Cluster Number register
 Clock
 programmable, 3-19
 real-time, 2-10
 Clock period, 1-4
 Cluster number register (CLN), 2-11
 Communication, inter-CPU, 2-11
 Computation section, 4-1
 Concurrent reads and writes, block, 2-5
 Condensing units, 1-13
 Configurations of system, 1-16
 Conflict, memory access, 2-7
 Control and data paths of CPU, 1-6
 Control, inter-CPU, 2-11
 Conventions, notational, 1-4
 Correctable Memory Error Mode flag, 3-10
 CP, see clock period
 CPU, see Central Processing Unit
 CPU operating registers
 A registers, 4-3
 address registers, 4-3
 B registers, 4-5
 S registers, 4-6
 scalar registers, 4-6
 T registers, 4-8
 V registers, 4-9
 Vector registers, 4-9
 CSB - read address, 3-8
 Current Address register (CA), 2-16
 Current Instruction Parcel register (CIP), 3-2
 Cycle time, memory, 2-1

Data Base Address register (DBA), 3-18
 Data formats
 integer, 4-22
 floating-point, 4-23
 Data Limit Address register (DLA), 3-18
 DBA register, see Data Base Address register
 Deadstart sequence, 3-21
 Derivation of the division algorithm, 4-31
 Disk control unit, 1-11
 Disk I/O processor (DIOP), 1-9
 Disk storage units, 1-11
 Division algorithm, 4-22, 4-30
 DLA register, see Data Limit Address register
 Double-precision numbers, 4-27

E - error type, 3-8
 Error correction, see SECEDED
 Exchange
 initiated by deadstart sequence, 3-14
 initiated by interrupt flag set, 3-14
 initiated by program exit, 3-14
 sequence issue conditions, 3-15
 sequence, 3-13
 Exchange Address (XA) register, 3-5
 Exchange mechanism, 3-5
 Exchange package, 3-5
 active, 3-13
 assignments, 3-7
 contents, 3-5

Exchange package, (continued)
 enable Second Vector Logical, 3-8
 management, 3-15
 memory error data, 3-8
 processor number, 3-7
 vector not used (VNU), 3-7
 Exchange package registers
 A registers, 3-12
 Cluster Number register, 3-12
 Exchange Address register, 3-9
 Flag register, 3-11
 Memory Field registers, 3-13
 Mode register, 3-9
 Program Address register, 3-13
 Program State register, 3-12
 S registers, 3-12
 Exchange request, memory ports, 2-6
 Exclusive NOR function, 4-36
 Exclusive OR function, 4-36
 Execution interval, 3-13
 Exponent matrix for floating-point multiply unit, 4-25
 External Interrupts flag, 3-10

F register, see Flag register
 Fetch
 following scalar store, 2-6
 request, 2-6
 Flag register, exchange package, 3-11
 Flags
 Bidirectional Memory Mode, 3-10
 Correctable Memory Error Mode, 3-10
 Exchange register flags, 3-11
 External Interrupts, 3-10
 Floating-point Error Mode, 3-10
 Monitor Mode, 3-10
 Operand Range Error Mode, 3-10
 Operand Range Error, 3-18
 Program Range Error, 3-18
 Semaphore, 3-9
 Uncorrectable Memory Error Mode, 3-10
 Floating-point
 Add functional unit, 4-20
 add functional unit range error, 4-24
 addition, 4-28
 arithmetic, 4-22
 data format, 4-23
 Error Mode flag, 3-10
 exponent matrix, 4-25
 functional units, 4-20
 integer multiply, 4-27
 Multiply functional unit, 4-20
 multiply functional unit out-of-range conditions, 4-25
 multiply partial-product sums pyramid, 4-29
 normalized numbers, 4-24
 range errors, 4-24
 range overflow, 4-24
 reciprocal approximation functional unit range error, 4-27
 subtraction, 4-27

Floating-point arithmetic, 4-22
 exponent range, 4-23
 underflow, 4-23

Functional units, 4-14
 address, 4-14
 Address Add, 4-15
 Address Multiply, 4-15
 Floating-point, 4-20
 Floating-point Add, 4-20
 Floating-point Multiply, 4-20
 Full Vector Logical, 4-18
 Reciprocal Approximation, 4-21
 scalar, 4-15
 Scalar Add, 4-15
 Scalar Logical, 4-16
 Scalar Population/Parity/Leading Zero, 4-16
 Scalar Shift, 4-16
 Second Vector Logical, 4-18
 vector, 4-16
 Vector Add, 4-17
 Vector Population/Parity, 4-19
 Vector Shift, 4-17
 vector reservation, 4-17

g field, 5-1
 Group descriptions, performance counter, C-2

h field, 5-1

i field, 5-1
 I/O channels, 2-6
 I/O memory
 access, 2-21
 access priority, 2-7
 addressing, 2-25
 conflicts, 2-24
 lockout, 2-24
 request conditions, 2-25
 I/O processors, types of, 1-9
 I/O Subsystem, data transfer, 2-16
 IBA register, see Instruction Base Address register
 ICD, see Interrupt Countdown counter
 II register, see Interrupt Interval register
 ILA register, see Instruction Limit Address register
 In-buffer condition, 3-4
 Inclusive OR function, 4-36
 Instruction
 descriptions, 5-6
 issue, 5-5
 summary, A-1
 Instruction Base Address register, 3-17
 Instruction buffers, 3-3
 Instruction fetch
 following scalar store, 2-6
 request, 2-6
 Instruction format
 1-Parcel with combined *j* and *k* fields, 5-2

Instruction format (continued)
 1-Parcel with discrete *j* and *k* fields, 5-1
 2-Parcel with combined *i*, *j*, *k*, and *m* fields, 5-3
 2-Parcel with combined *j*, *k*, and *m* fields, 5-2
 Instruction issue
 and control elements, 3-1
 to memory ports, 2-5
 Instruction Limit Address register (ILA), 3-17
 Instruction parcel, 3-1
 Instructions, general form for, 5-1
 Integer arithmetic, 4-21
 Integer data formats, 4-22
 Inter-CPU
 communication and control, 2-11
 memory access priority, 2-7
 Interfaces, 1-7
 Intermediate registers, 4-3
 Interrupt Countdown Counter (ICD), 3-20
 Interrupt Interval register (II), 3-19
 Issue, 3-2

j field, 5-1

k field, 5-1

Logical operations
 AND function, 4-35
 exclusive NOR function, 4-36
 exclusive OR function, 4-36
 inclusive OR function, 4-36
 mask, 4-36
 Lower Instruction Parcel register (LIP), 3-3

m field, 5-1
 M register, see Mode register
 Managing Exchange package, 3-5
 Mask operation, 4-36
 Mass storage, 1-11
 Master Clear sequence, to external device, 2-21
 Master I/O processor (MIOP), 1-9
 Memory, see Central Memory
 Memory access conflicts
 bank busy, 2-7
 section access, 2-7
 simultaneous bank, 2-7
 Memory bank conflicts, 2-24
 Memory data path with SECEDED, 2-8
 Memory error data fields, 3-8
 Memory field protection, 3-16
 Memory reference conflict resolution, 2-7
 Mode register (M), 3-8
 Monitor Mode flag, 3-10
 Motor-generator units, 1-15
 Multi-CPU programming of 6 Mbyte per second channels, 2-17

Multiplication algorithm, 4-28
 Multiply pyramid, 4-28

 Newton's method, 4-30
 Next Instruction Parcel register (NIP), 3-2
 Normalized floating-point numbers, 4-23
 Notation conventions, 1-4

 Operand
 range error, 3-19
 Range Error flag, 3-19
 Range Error Mode flag, 3-10
 Operating registers, see CPU operating registers
 Organization of system, 1-5
 Organization, memory, 2-2
 Out-of-buffer condition, 3-4

 P register, see Program Address register
 Parallel vector operations, 4-11
 Parity error, 2-20
 Performance counter group descriptions, C-2
 Performance events, selecting, C-1
 Performance monitor, 3-20
 instructions, C-1
 Physical dimensions of system, 1-3
 PN, see Processor number
 Power distribution units, 1-14
 Processor Number (PN), 3-7
 Program
 Address register (P), 3-2
 range error, 3-18
 Range Error flag, 3-18
 State register (PS), 3-11
 Programmable clock, 3-19
 Programmed Master Clear to external device, 2-21

 R - read mode, 3-8
 Read address, 3-8
 Read mode, 3-8
 Reading performance results, C-3
 Real-time clock, 2-10
 Real-time Clock register (RTC), 2-10
 Reciprocal Approximation functional unit, 4-21
 Reciprocal Approximation functional unit iterations, 4-33
 References, memory, 2-5
 Registers
 8-bit status, 4-8
 Address (A), 4-3
 Beginning Address, 3-3
 Channel Limit (CL), 2-16
 Cluster Number (CLN), 2-11
 Current Address (CA), 2-16, 2-25
 Current Instruction Parcel (CIP), 3-2
 Data Base Address, 3-18
 Data Limit Address, 3-18
 Exchange Address (XA), 3-5

Registers (continued)
 Exchange, see Exchange registers
 Flag (F), 3-11
 Instruction Base Address, 3-17
 Instruction Limit Address, 3-17
 Intermediate, 4-3
 Interrupt Interval, 3-19
 Limit Address (CL), 2-16, 2-25
 Lower Instruction Parcel (LIP), 3-3
 Mode (M), 3-8
 Next Instruction Parcel (NIP), 3-2
 operating, see CPU operating registers
 Program Address, 3-2
 Program State (PS), 3-12
 Real-time Clock register, 2-10
 scalar registers (S), 4-6
 Semaphore, 2-12
 shared, 2-11
 Shared Address, 2-12
 Shared Scalar, 2-12
 Vector Length, 4-13
 Vector Mask, 4-13
 RTC register, see Real-time Clock register

 S - syndrome, 3-8
 S registers, see Scalar registers
 SB registers, see Shared Address registers
 Scalar
 Add functional unit, 4-15
 functional units, 4-15
 Logical functional unit, 4-16
 memory references, 2-5
 registers (S), 4-6
 Population/Parity/Leading Zero functional unit, 4-16
 Shift functional unit, 4-16
 SECEDED, 2-8
 SECEDED maintenance functions
 instructions, D-1
 verification of check bit storage, D-1
 verification of check bit generation, D-2
 verification of error detection and correction, D-2
 Second Vector Logical unit enable/disable, 4-18
 Second Vector Logical/Floating-point Multiply input, output data paths, 4-19
 Selecting performance events, C-1
 Semaphore flag, 3-9
 Semaphore registers, 2-12
 Shared
 address registers, 2-12
 register access conflicts, 2-13
 registers, 2-11
 resources of CPU, 2-1
 scalar registers, 2-12
 SM registers, see Semaphore registers
 Solid-state Storage Device, 1-12
 data transfer, 2-15
 Special register values, 5-4
 ST registers, see Shared Scalar registers
 Status register, 4-8

Syndrome, 2-9, 3-8

System

- basic organization, 1-5
- characteristics, 1-3
- configurations, 1-16
- physical dimensions of, 1-3

T registers, see Intermediate scalar registers

Testing performance counters, C-3

Time slot, 2-21

Transfer rates, memory, 2-1

Twos complement integer arithmetic, 4-22

Uncorrectable Memory Error Mode flag, 3-10

Unexpected Ready signal, 2-20

V registers, see Vector registers

V register reservations and chaining, 4-12

Vector

- Add functional unit, 4-17
- Length register, 4-13
- logical functional units, 4-16
- Mask register (VM), 4-13
- Population/Parity functional unit, 4-19
- processing, 4-1
- register as result and operand
 - register, 4-13
- register parallel operations, 4-11
- Shift functional unit, 4-17

VL register, see Vector Length register

VM register, see Vector Mask register

VNU - vector not used, 3-7

Word assembly/disassembly for 6 Mbyte per second channel, 2-18

Word size, memory, 2-1

XA register, see Exchange Address register

XIOP, see Auxiliary I/O processor

READERS COMMENT FORM

CRAY X-MP Series Models 22 and 24 Mainframe Reference Manual

HR-0032 A

Your comments help us to improve the quality and usefulness of our publications. Please use the space provided below to share with us your comments. When possible, please give specific page and paragraph references.

NAME _____

JOB TITLE _____

FIRM _____

ADDRESS _____

CITY _____ STATE _____ ZIP _____

CRAY
RESEARCH, INC.

CUT ALONG THIS LINE

FOLD



NO POSTAGE
NECESSARY
IF MAILED
IN THE
UNITED STATES

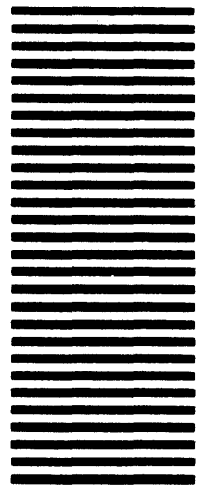

BUSINESS REPLY CARD
FIRST CLASS PERMIT NO 6184 ST PAUL, MN

POSTAGE WILL BE PAID BY ADDRESSEE



**1440 Northland Drive
Mendota Heights, MN 55120
U.S.A.**

Attention:
PUBLICATIONS

FOLD

STAPLE

READERS COMMENT FORM

CRAY X-MP Series Models 22 and 24 Mainframe Reference Manual

HR-0032 A

Your comments help us to improve the quality and usefulness of our publications. Please use the space provided below to share with us your comments. When possible, please give specific page and paragraph references.

NAME _____

JOB TITLE _____

FIRM _____

ADDRESS _____

CITY _____ STATE _____ ZIP _____

CRAY
RESEARCH, INC.

CUT ALONG THIS LINE

FOLD



NO POSTAGE
NECESSARY
IF MAILED
IN THE
UNITED STATES



BUSINESS REPLY CARD

FIRST CLASS PERMIT NO 6184 ST PAUL, MN

POSTAGE WILL BE PAID BY ADDRESSEE



Attention:
PUBLICATIONS

**1440 Northland Drive
Mendota Heights, MN 55120
U.S.A.**

FOLD

STAPLE

CRAY

RESEARCH, INC.

Any shipment to a country outside of the United States requires a U.S. Government export license.

CRAY COMPUTER SYSTEMS

**CRAY X-MP SERIES
MODEL 48
MAINFRAME REFERENCE MANUAL
HR-0097**

Copyright© 1984 by CRAY RESEARCH, INC. This manual or parts thereof may not be reproduced in any form without permission of CRAY RESEARCH, INC.

PREFACE

This publication describes the CRAY X-MP Series Model 48 Computer System. It is written to assist programmers and engineers and assumes a familiarity with digital computers.

The manual describes the overall computer system, its configurations, and equipment. It also describes the operation of the Central Processing Units that execute instructions, provide memory protection, report hardware exceptions, and provide interprocessor communications within the system.

Details of the I/O Subsystem, the disk storage units, and the Solid-state Storage Device are given in the following publications:

- HR-0030 I/O Subsystem Hardware Reference Manual
- HR-0630 Mass Storage Subsystem Hardware Reference Manual
- HR-0031 Solid-state Storage Device (SSD[®]) Reference Manual

////////////////////////////////////

WARNING

This equipment generates, uses, and can radiate radio frequency energy and if not installed and used in accordance with the instructions manual, may cause interference to radio communications. It has been tested and found to comply with the limits for a Class A computing device pursuant to Subpart J of Part 15 of FCC Rules, which are designed to provide reasonable protection against such interference when operated in a commercial environment. Operation of this equipment in a residential area is likely to cause interference in which case the user at his own expense will be required to take whatever measures may be required to correct the interference.

////////////////////////////////////

CONTENTS

<u>PREFACE</u>	iii
1. <u>SYSTEM DESCRIPTION</u>	1-1
INTRODUCTION	1-1
CONVENTIONS	1-1
Italics	1-1
Register conventions	1-3
Number conventions	1-4
Clock period	1-4
SYSTEM COMPONENTS	1-4
Central Processing Units	1-5
Interfaces	1-7
I/O Subsystem	1-8
Disk storage units	1-10
Solid-state Storage Device	1-11
Condensing units	1-13
Power distribution units	1-14
Motor-generator units	1-15
SYSTEM CONFIGURATION	1-16
2. <u>CPU SHARED RESOURCES</u>	2-1
INTRODUCTION	2-1
CENTRAL MEMORY	2-1
Memory organization	2-2
Memory addressing	2-3
Memory access	2-3
Conflict resolution	2-5
Bank Busy conflict	2-6
Simultaneous Bank conflict	2-6
Section Access conflict	2-6
Memory access priorities	2-6
Memory error correction	2-6
INTER-CPU COMMUNICATION SECTION	2-9
Real-time clock	2-9
Inter-CPU communication and control	2-10
Shared Address and Shared Scalar registers	2-11
Semaphore registers	2-11
Shared register and semaphore conflicts	2-12

EXCHANGE MECHANISM (continued)	
Exchange initiated by interrupt flag set	3-14
Exchange initiated by program exit	3-14
Exchange sequence issue conditions	3-15
Exchange package management	3-15
MEMORY FIELD PROTECTION	3-16
Instruction Base Address register	3-17
Instruction Limit Address register	3-17
Data Base Address register	3-18
Data Limit Address register	3-18
Program range error	3-18
Operand range error	3-19
PROGRAMMABLE CLOCK	3-19
Instructions	3-19
Interrupt Interval register	3-19
Interrupt Countdown counter	3-20
Clear programmable clock interrupt request	3-20
PERFORMANCE MONITOR	3-20
DEADSTART SEQUENCE	3-21

4. <u>CPU COMPUTATION SECTION</u>	4-1
INTRODUCTION	4-1
OPERATING REGISTERS	4-3
ADDRESS REGISTERS	4-3
A registers	4-3
B registers	4-5
SCALAR REGISTERS	4-6
S registers	4-6
T registers	4-8
VECTOR REGISTERS	4-9
V registers	4-9
V register reservations and chaining	4-12
Vector control registers	4-13
Vector Length register	4-13
Vector Mask register	4-13
FUNCTIONAL UNITS	4-13
Address functional units	4-14
Address Add functional unit	4-14
Address Multiply functional unit	4-14
Scalar functional units	4-15
Scalar Add functional unit	4-15
Scalar Shift functional unit	4-15
Scalar Logical functional unit	4-16
Scalar Population/Parity/Leading Zero functional unit	4-16
Vector functional units	4-16
Vector functional unit reservation	4-16

B.	<u>6 MBYTE PER SECOND CHANNEL DESCRIPTIONS</u>	B-1
	INTRODUCTION	B-1
	6 MBYTE PER SECOND INPUT CHANNEL SIGNAL SEQUENCE	B-1
	Data bits 2 ⁰ through 2 ¹⁵	B-1
	Parity bits 0 through 3	B-2
	Ready signal	B-3
	Resume signal	B-3
	Disconnect signal	B-3
	6 MBYTE PER SECOND OUTPUT CHANNEL SIGNAL SEQUENCE	B-3
	Data bits 2 ⁰ through 2 ¹⁵	B-4
	Parity bits 0 through 3	B-5
	Ready signal	B-5
	Resume signal	B-5
	Disconnect signal	B-5
C.	<u>PERFORMANCE MONITOR</u>	C-1
	INTRODUCTION	C-1
	SELECTING PERFORMANCE EVENTS	C-1
	READING PERFORMANCE RESULTS	C-3
	TESTING PERFORMANCE COUNTERS	C-3
D.	<u>SECDED MAINTENANCE FUNCTIONS</u>	D-1
	INTRODUCTION	D-1
	VERIFICATION OF CHECK BIT STORAGE	D-1
	VERIFICATION OF CHECK BIT GENERATION	D-2
	VERIFICATION OF ERROR DETECTION AND CORRECTION	D-2
	CLEARING MAINTENANCE MODE FUNCTIONS	D-3

FIGURES

1-1	CRAY X-MP Model 48 mainframe with a Cray I/O Subsystem and an SSD	1-2
1-2	Basic organization of the 4-processor system	1-5
1-3	Control and data paths for a single CPU	1-6
1-4	Typical interface cabinet	1-8
1-5	I/O Subsystem chassis	1-9
1-6	DD-29 Disk Storage Unit	1-11
1-7	Solid-state Storage Device chassis	1-12
1-8	Condensing unit	1-13
1-9	Power distribution units	1-14
1-10	Motor-generator equipment	1-15
1-11	Block diagram of the four-processor system with full disk capacity	1-16
1-12	Block diagram of the four-processor system with block multiplexer channels	1-17
2-1	Central Memory organization for a 4-processor system	2-2

SYSTEM DESCRIPTION

1

INTRODUCTION

The CRAY X-MP model 48 Computer System is a powerful, general purpose machine that contains four central processing units (CPUs). Like all CRAY X-MP multiprocessor systems, it is able to achieve extremely high multiprocessing rates by efficiently using the scalar and vector capabilities of all CPUs combined with the system's random-access solid-state memory (RAM) and shared registers.

Vector processing is the performance of iterative operations on sets of ordered data. When two or more vector operations are chained together, two or more operations can be executing each 9.5-nanosecond clock period, greatly exceeding the computational rates of conventional scalar processing. Scalar operations complement the vector capability by providing solutions to problems not readily adaptable to vector techniques.

The machine has very high performance levels, and equipment options allow systems to be configured for a particular use. Central Memory of the 4-processor mainframe is 8 million 64-bit words (see table 1-1). The system is compatible with all existing models of the Cray I/O Subsystem and its associated mass storage subsystem. In addition, an optional high-performance Cray Solid-state Storage Device (SSD) can be attached to the mainframe. Figure 1-1 illustrates the mainframe with a Cray I/O Subsystem and an SSD.

This section describes system components and configurations. Table 1-1 gives overall system characteristics.

CONVENTIONS

The following conventions are used in this manual.

ITALICS

Italicized lowercase letters, such as *jk*, indicate variable information.

Table 1-1. CRAY X-MP 4-processor system characteristics

Configuration	<ul style="list-style-type: none"> - Mainframe with 4 Central Processing Units (CPUs) - I/O Subsystem with 2, 3, or 4 I/O Processors - Optional Solid-state Storage Device (SSD)
CPU speed	<ul style="list-style-type: none"> - 9.5 ns CPU clock period - 105 million floating-point additions per second per CPU - 105 million floating-point multiplications per second per CPU - 105 million half-precision floating-point divisions per second per CPU - 33 million full-precision floating-point divisions per second per CPU - Simultaneous floating-point addition, multiplication, and reciprocal approximation within each CPU
Memory	<ul style="list-style-type: none"> - Mainframe has 8 million (model 48) 64-bit words in Central Memory
Input/Output	<ul style="list-style-type: none"> - Two 1250 Mbyte per second channel pairs for interface to Solid-state Storage Device (SSD) - Four 100 Mbyte per second channel pairs for interface to I/O Subsystem - Four 6 Mbyte per second channel pairs
Physical	<ul style="list-style-type: none"> - 64 sq ft floor space for mainframe - 15 sq ft floor space for I/O Subsystem - 15 sq ft floor space for SSD - 5.65 tons, mainframe weight - 1.5 tons, I/O Subsystem weight - 1.5 tons, SSD weight - Liquid refrigeration of each chassis - 400 Hz power from motor-generators

REGISTER CONVENTIONS

Parenthesized register names are used frequently in this manual as a form of shorthand notation for the expression "the contents of register ---." For example, "Branch to (P)" means "Branch to the address indicated by the contents of register P."

CENTRAL PROCESSING UNITS

Each CPU has independent control and computation sections. All CPUs share Central Memory and the inter-CPU communication and I/O sections. (CPU sections are described in later sections.) Figure 1-2 shows the mainframe chassis. Figure 1-2 illustrates the basic organization of the computer; figure 1-3 illustrates the components and control and data paths of each CPU in the system.

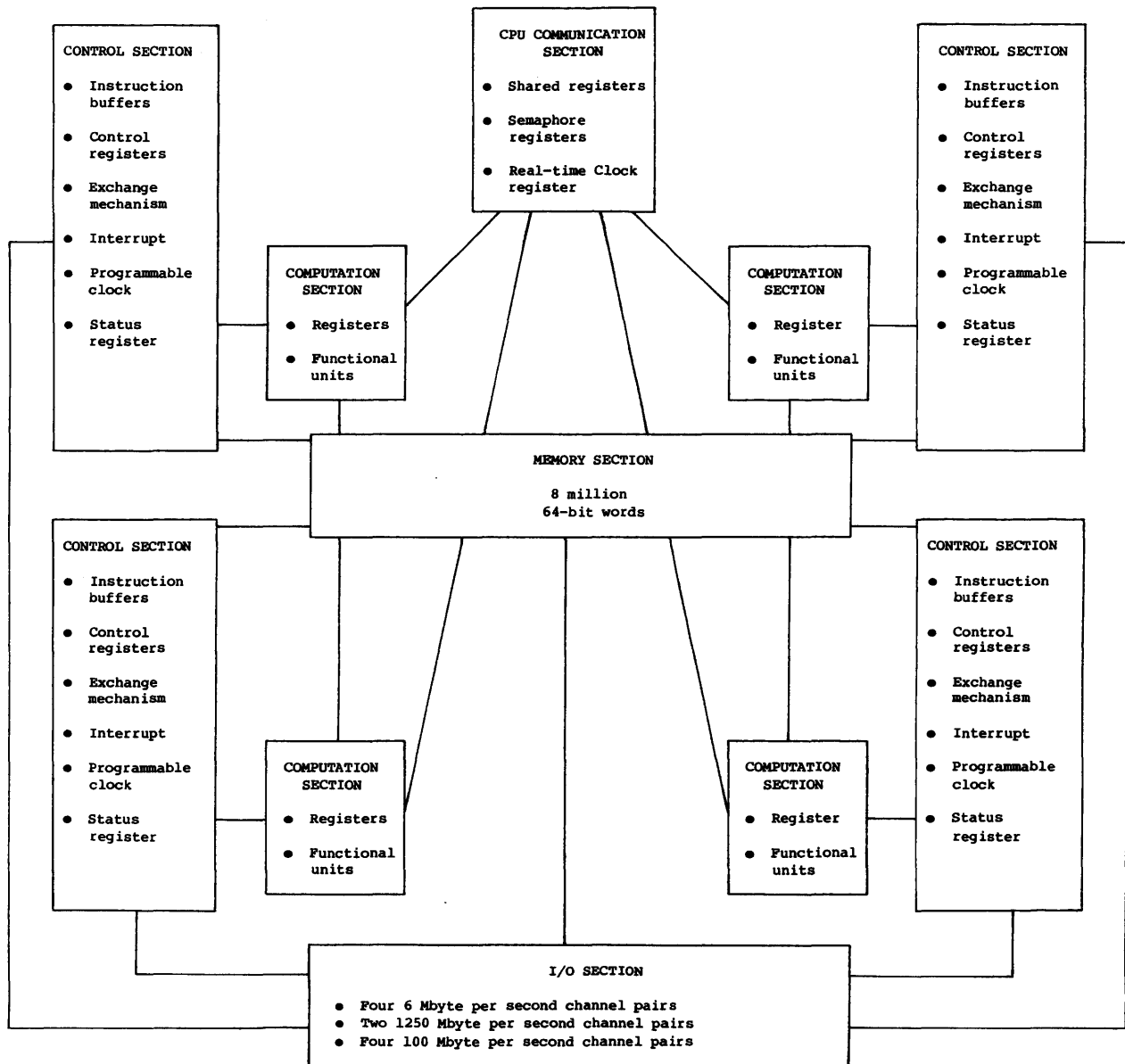

Figure 1-2. Basic organization of the 4-processor system

INTERFACES

The Cray system is designed for use with front-end computers in a computer network. A front-end computer system is self contained and executes under the control of its own operating system.

Standard interfaces connect the Cray mainframe's I/O channels to channels of front-end computers, providing input data to the Cray system and receiving output from it for distribution to peripheral equipment. Interfaces compensate for differences in channel widths, machine word size, electrical logic levels, and control signals. (The Master I/O Processor of the I/O Subsystem communicates with the mainframe through a 6 Mbyte per second channel pair to a channel adapter module in the Cray mainframe.) Communication continues through a front-end interface, to the front-end computer typically through a front-end computer I/O channel.

The front-end interface is housed in a stand-alone cabinet (figure 1-4) located near the host computer. Its operation is invisible to the front-end computer user and the Cray user.

A primary goal of the interface is to maximize the use of the front-end channel connected to the Cray system. Since the MIOP channel connected to the interface is faster than any front-end channel connected to the interface, the burst rate of the interface is limited by the maximum rate of the front-end channel.

Interfaces to front-end computers allow the front-end computers to service the Cray Computer System in the following ways:

- As a master operator station
- As a local operator station
- As a local batch entry station
- As a data concentrator for multiplexing several other stations into a single Cray channel
- As a remote batch entry station
- As an interactive communication station

Peripheral equipment attached to the front-end computer varies depending on the use of the Cray system.

The Master I/O Processor (MIOP) controls the front-end interfaces and the standard group of station[†] peripherals. The Peripheral Expander interfaces the station peripherals to one direct memory access (DMA) port of the MIOP. The MIOP also connects to Buffer Memory and to the

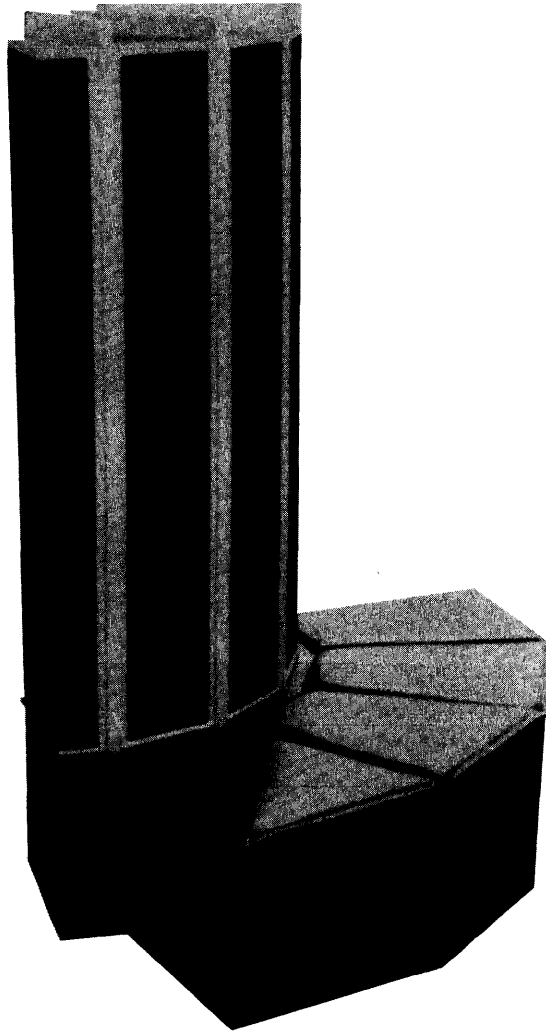

Figure 1-5. I/O Subsystem chassis

[†] The term station means both hardware and software. Station is the link to the front end or can act as a limited front end (as the MIOP).

Each DSU has two accesses for connecting it to controllers. The second independent data path to each DSU exists through another Cray Research, Inc., controller. Reservation logic provides controlled access to each DSU. Dynamic sharing of devices is not supported by the Cray Operating System (COS) software. Further information about the mass storage subsystem is included in the I/O Subsystem Reference Manual, CRI publication HR-0030, and the Mass Storage Subsystem Hardware Reference Manual, CRI publication HR-0630.

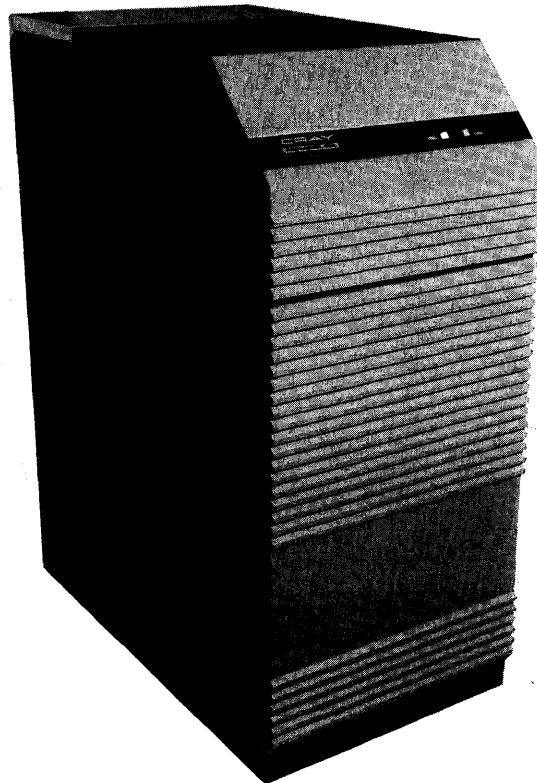

Figure 1-6. DD-49 Disk Storage Unit

SOLID-STATE STORAGE DEVICE

The Solid-state Storage Device (SSD) shown in figure 1-7 is used for temporary data storage and transfers data to and from the mainframe's Central Memory. The transfer speed is dependent on the SSD memory size and configuration as described in the Solid-state Storage Device (SSD) Reference Manual, CRI publication HR-0031. The maximum speed attained from the SSD to Central Memory is 1250 Mbytes per second for each 1250 Mbyte channel.



Cray Research, Inc.
Publications Department
1440 Northland Drive
Mendota Heights, MN 55120
612-452-6650
TLX 298444