

OPTICAL CLOCK MODULE

Optical Clock Module Overview	3
Module Components	4
Oscillators	4
Integrated Circuits (ICs)	5
Optical Transmitter Module (OTM)	5
Coupler	6
Connectors	6
CRAY T94 Clock Deck	7
Optical Clock Path	8
Clock Distribution on System Modules	10
Laser Safety: CRAY T90 Series Systems as Laser Products	11

FIGURES

Figure 1. Optical Clock Signal Path	3
Figure 2. Optical Clock Module	4
Figure 3. CRAY T94 Clock Deck	7
Figure 4. Optical Clock Path	8
Figure 5. Optical Clock Module Block Diagram	9
Figure 6. System Module Clock Distribution Block Diagram ...	10
Figure 7. Sample Caution Label for a Class I Laser Product	12

TABLES

Table 1. CRAY T90 Series OTM Specifications	5
Table 2. Right-angle Head Connectors	6
Table 3. Laser Classes	11

DO NOT WRITE
ON THESE SLIDES

Optical Clock Module Overview

The optical clock module generates an optical clock signal and sends it to all system modules. Each CRAY T90 series system has one optical clock module. In CRAY T94 systems, the optical clock module is mounted on a clock deck and is located on the top of the card cage. In CRAY T932 and CRAY T916 systems, the optical clock module is located between memory module stack D and memory module stack H and is labeled Clock Box. The optical clock module has its own power supply. Refer to the appropriate CRAY T90 Series Power, Cooling and Control System document for more information on the clock module power supply.

The optical clock module consists of two 4 in. x 9 in. printed circuit boards: an oscillator board and a laser board. The oscillator board contains the oscillators and integrated circuits. The laser board contains the optical transmitter modules (OTMs), which house the lasers. Two types of laser boards are available: LP01 for CRAY T94 systems and HP01 for CRAY T916 and CRAY T932 systems.

NOTE: Future optical clock modules will be one PC board; the two clock module types will be the clock module high power (OH01) and clock module low power (OL01) for CRAY T916/T932 systems and CRAY T94 systems, respectively. Both module types are identical; however, the specifications for the OTMs on the two modules differ. The OH01 clock module OTM contains a more powerful laser than the OL01 clock module OTM.

Figure 1 shows the path of the optical clock signal. The oscillators generate an electrical clock signal and send it to the OTMs, which convert it to an optical signal and then send it through the fiber-optic waveguides to an optical receiver on each system module. The optical receiver converts the signal back to an electrical signal and distributes it to a TZ option, which, in turn, distributes it to each option on the system module.

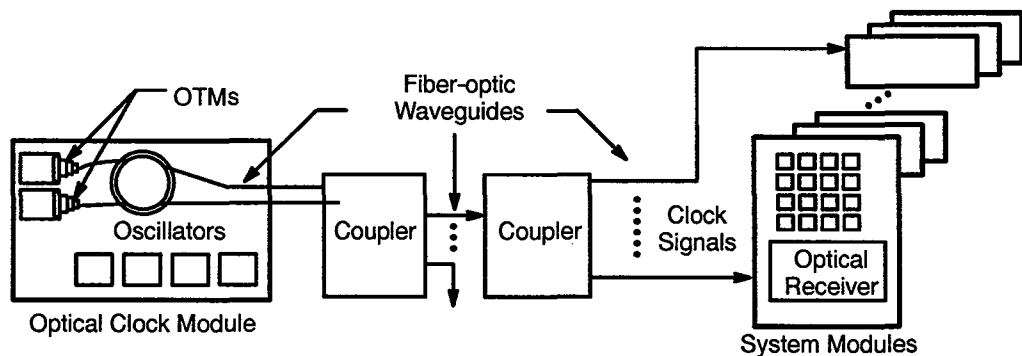

Figure 1. Optical Clock Signal Path

Module Components

An optical clock module consists of oscillators, optical transmitter modules (OTMs), integrated circuits (ICs), and connectors. Figure 2 illustrates the components on an optical clock module.

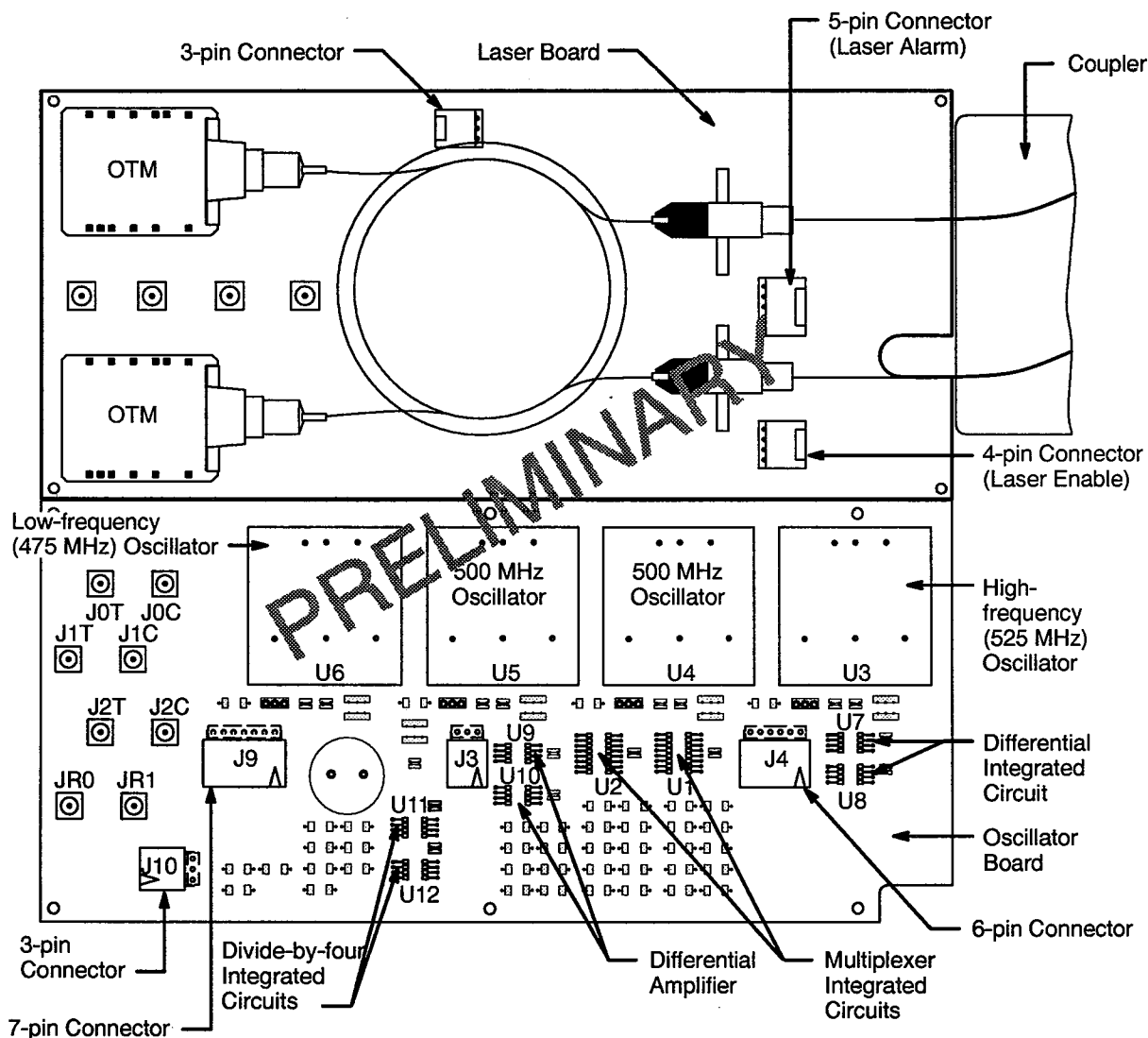

Figure 2. Optical Clock Module

Oscillators

The oscillators create a differential electronic clock (ECL level) signal to drive the OTMs. Four oscillators on the module allow for three different clock frequency levels: the U4 and U5 oscillators provide a 500-MHz clock signal, the high-frequency oscillator provides a 525-MHz frequency

signal, and the low-frequency oscillator provides a 475-MHz frequency signal. Oscillators U4 and U5 are the normal clock frequency oscillators, which provide the CRAY T90 systems with a 2-ns clock. Two normal frequency oscillators are available for redundancy purposes; if one oscillator fails, the second oscillator generates the clock signal. The second oscillator is selected by the control system. The system instantly stops if the clock is lost.

Integrated Circuits (ICs)

The optical clock module uses three types of integrated circuits: multiplexer, differential amplifiers, and divide-by-4 ICs. The multiplexer ICs select one of four paths, based on the input they receive from the control system. The paths are the high-frequency oscillator, low-frequency oscillator, the normal clock frequency oscillator, and the external generator. The differential amplifier ICs amplify the signals going to the OTMs or coming from the control system. The divide-by-4 ICs direct the signal to the trigger source for the respective multiplexer IC. The trigger source ensures an accurate clock signal reference point.

Optical Transmitter Module (OTM)

The OTMs contain the lasers that send the optical signals through the fiber-optic waveguides to the optical receiver on the system modules. The specifications for the lasers are different for the various models of CRAY T90 series systems. Table 1 lists the laser specifications for the OTMs in CRAY T932, CRAY T916, and CRAY T94 systems.

Table 1. CRAY T90 Series OTM Specifications

Specification	System	
	CRAY T932 and CRAY T916 (OH01)	CRAY T94 (OL01)
Rated power	12.229 milliwatt (mW)	2 milliwatt (mW)
Operating peak power	10 mW	1 mW
Operating average power	5 mW	0.5 mW
Wavelength	1290 nm	1300 nm
Pulse frequency	500 MHz nominal, range 400 MHz to 550 MHz	500 MHz nominal, range 400 MHz to 550 MHz

Coupler

The coupler splits the clock signal coming from the OTM and sends it to the system modules. Two levels of couplers are associated with each optical clock module. In CRAY T94 systems, the coupler on the clock deck is a 2-by-2 coupler: two inputs (coming from the two OTMs) and two outputs (~~the other only one output is used~~). This coupler sends the optical clock signal to a 1-by-8 coupler. The 1-by-8 coupler splits the signal and sends it to 8 different system modules.

In CRAY T916 and CRAY T932 systems, the coupler coming off the module is a 4-by-4 coupler in which only two inputs are used (one from each OTM). Only two outputs are used in CRAY T916 systems, and all four outputs are used in CRAY T932 systems (refer to Figure 4). This coupler sends the optical clock signal to a 1-by-24 coupler, which splits the signal and sends it to up to 24 different system modules.

Connectors

The optical clock module has two types of connectors: right-angle head connectors and SMA jacks. Table 2 describes the function of the five different right-angle head connectors. The SMA jacks are the connectors for the external generator source and the trigger source.

Table 2. Right-angle Head Connectors

Connector Description	Connector Function
3-pin	Power. Powers on the optical clock module.
4-pin	Laser Enable. Enables one of two lasers.
5-pin	Laser alarm.
6-pin	Oscillator path select. Selects one of four paths: low frequency, high frequency, normal frequency, or external generator.
7-pin	Oscillator power select. Powers on the selected oscillator.

CRAY T94 Clock Deck

In CRAY T94 systems, the optical clock module is mounted on a clock deck. The clock deck sits on top of the card cage. The clock deck is a field replaceable unit (FRU) if the coupler fails; however, if the optical clock module fails, then the module becomes the FRU instead of the clock deck.

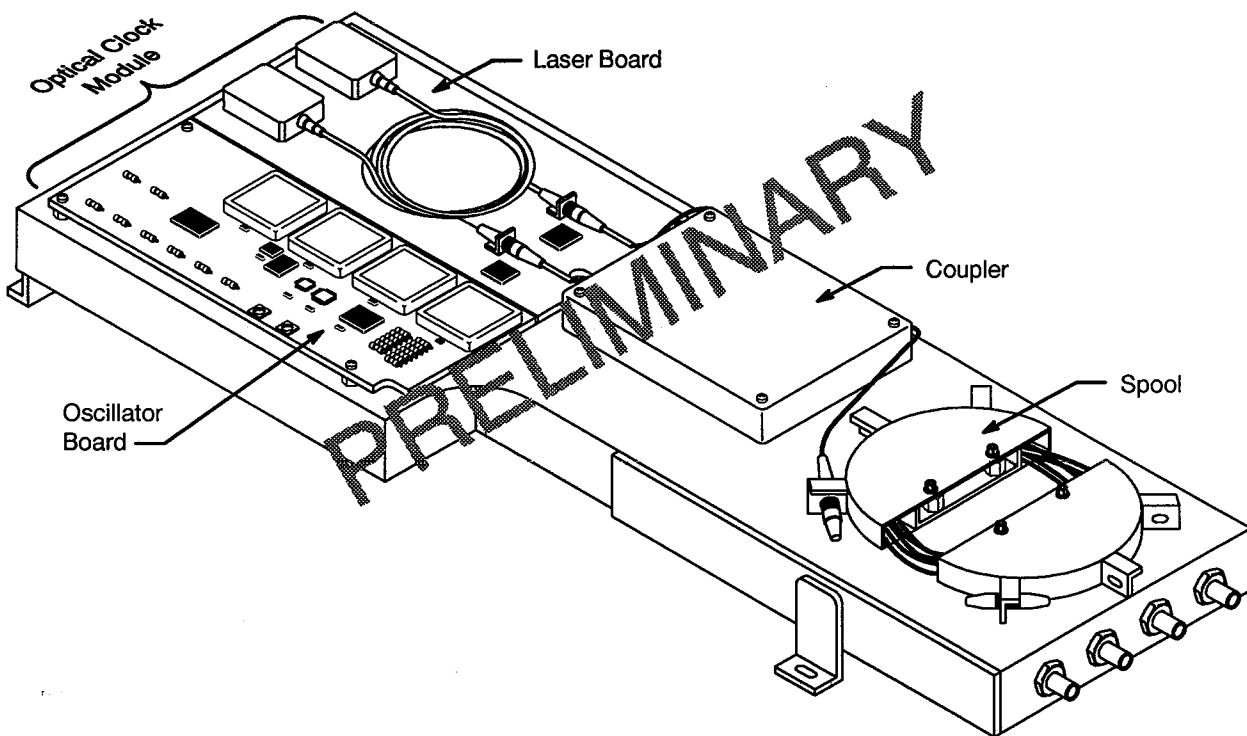

Figure 3. CRAY T94 Clock Deck

Optical Clock Path

Figure 4 shows the optical clock path for CRAY T94, CRAY T916, and CRAY T932 systems. In CRAY T94 systems, the optical clock module is capable of sending the clock signal to 16 system modules. In CRAY T916 and CRAY T932 systems, the optical clock module is capable of sending the clock signal to up to 96 different system modules. In CRAY T932 systems, each output of the 1-by-24 coupler can connect within any one of the four quadrants of the mainframe.

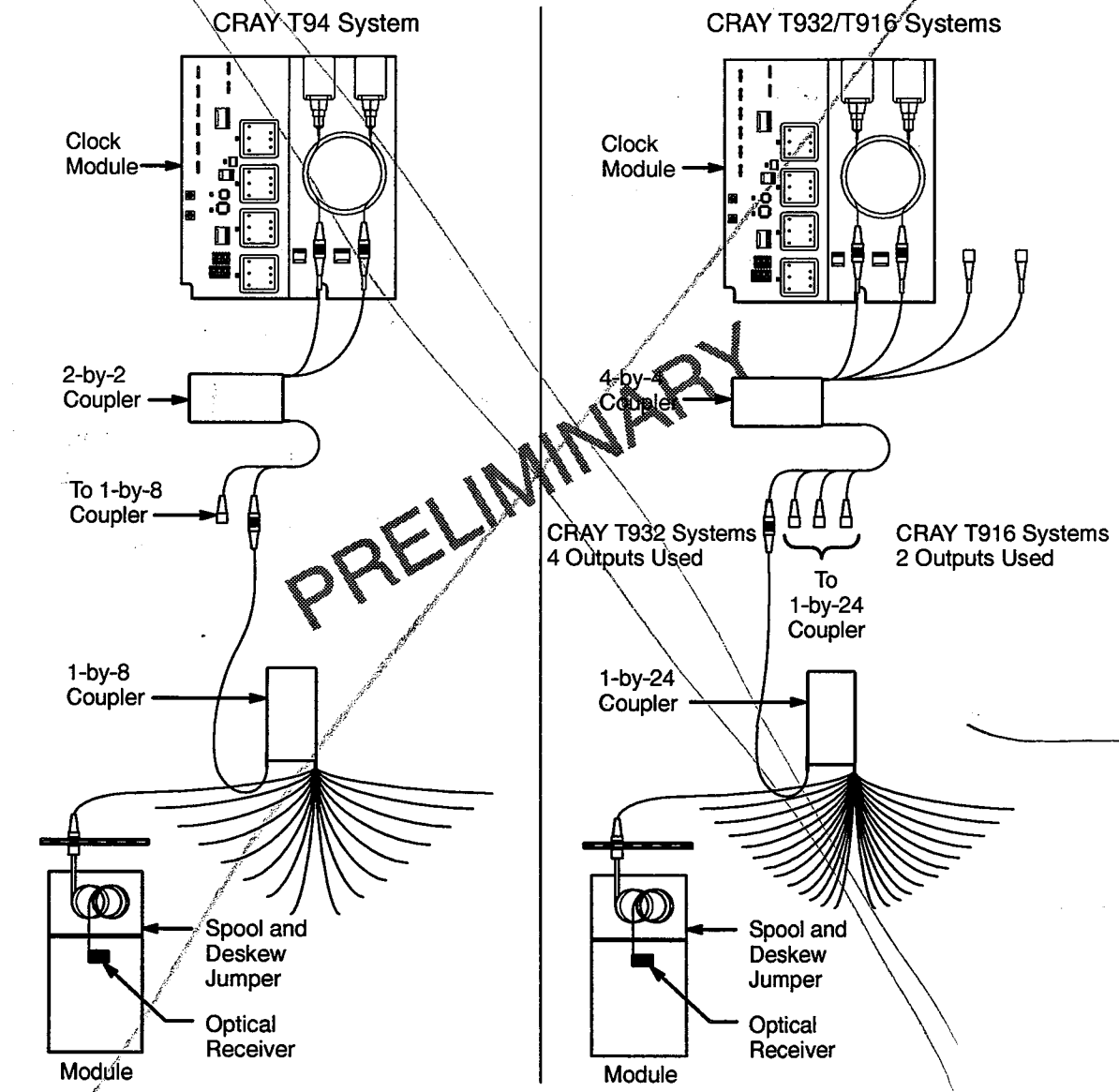

Figure 4. Optical Clock Path

Optical Clock Path

Figure 4 shows the optical clock path for CRAY T94, CRAY T916, and CRAY T932 systems. In CRAY T94 systems, the optical clock module is capable of sending the clock signal to 16 system modules. In CRAY T916 and CRAY T932 systems, the optical clock module is capable of sending the clock signal to up to 96 different system modules. In CRAY T932 systems, each output of the 1-by-24 coupler can connect within any one of the four quadrants of the mainframe.

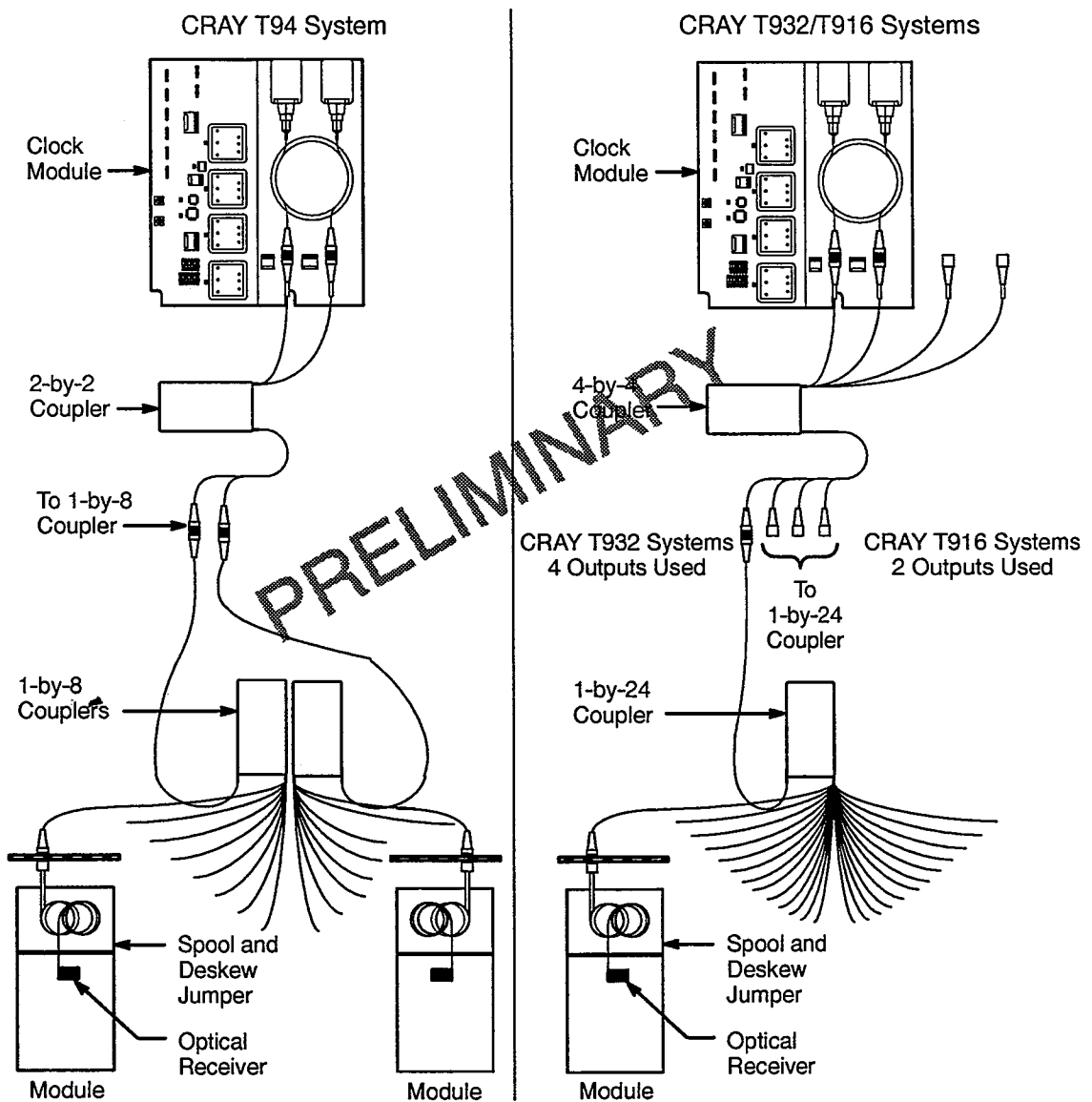

Figure 11. Optical Clock Path

C

C

C

Figure 5 is a block diagram of the optical clock path. The control system sends three signals simultaneously to the optical clock module. One signal selects a path to enable the multiplexer, another signal powers on the specified oscillator or external generator, and a third signal powers on the associated OTM.

The selected oscillator (or external generator) sends an electric clock pulse to the multiplexer. The multiplexer sends the signal through a divide-by-4 IC and a differential amplifier IC. The divide-by-4 IC sends the signal to the trigger source. The differential amplifier IC sends the signal to the associated OTM. The OTM converts the electrical signal to an optical signal and then sends it to the optical receiver on the system module.

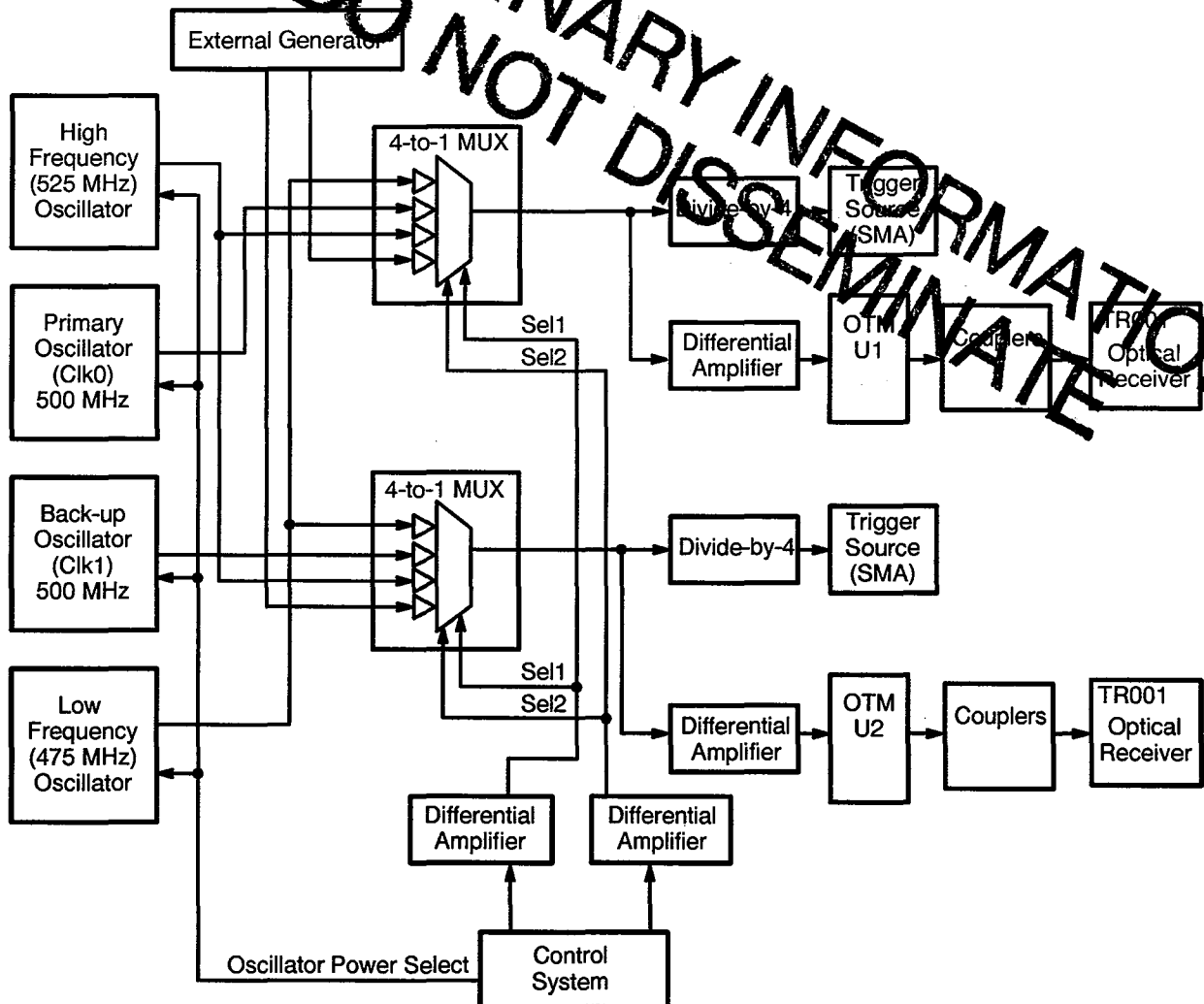

Figure 5. Optical Clock Module Block Diagram

Clock Distribution on System Modules

Each system module has an optical receiver (TR001) that converts the optical signal back to an electrical signal. The optical receiver then sends the T/C clk signal to the TZ option. The TZ option sends a true and complement copy of this signal to each option on the module. The TP connector receives the **Output T/C Null** signal, which is a deskew point for probing the clock signal on the module. The other 81 TZ option outputs (OAB through ODR) go to the module options and enter the options as a **Clock Input** signal, Boolean term IZY.

The TZ option has forced inputs on 23 different pins (IBA through IBW) for encoding module identification information including the module type and module serial number. The boundary scan register (BSR) obtains this data and uses it for boundary scan functions. For more information on boundary scan and module identification, read the *BS Module* document, publication number HTM-xxxx.

The TZ option also has two forced input signals: **Output Select 0** and **Output Select 1**. These signals allow for four different TZ option output configurations, which turn off unused outputs to help reduce the amount of noise on the module.

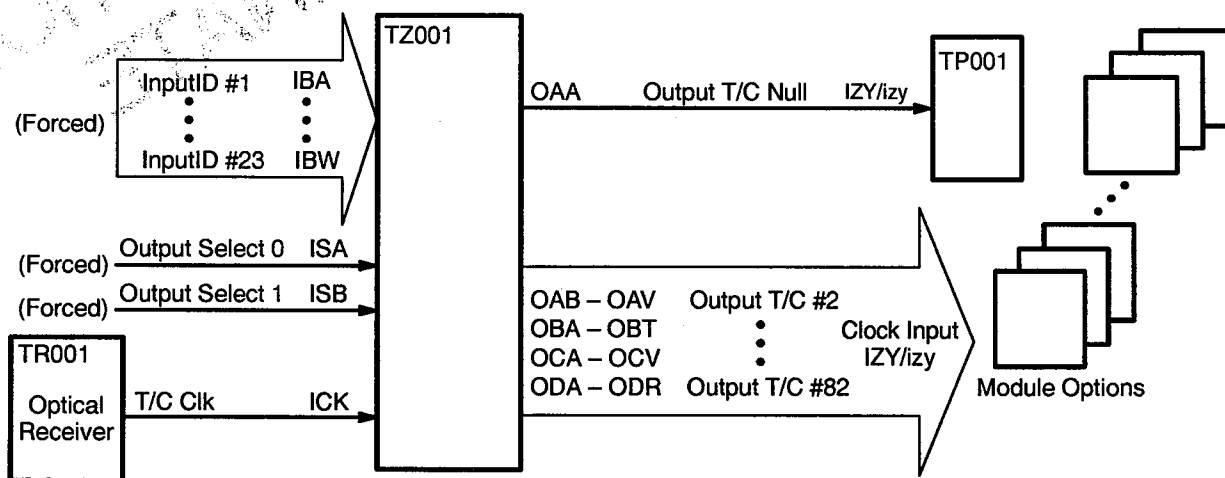

NOTE: Each differential output pair from the TZ option can drive two options on directly opposite sides of a system module.

Figure 6. System Module Clock Distribution Block Diagram

Laser Safety: CRAY T90 Series Systems as Laser Products

The CRAY T90 series systems are considered laser products because they incorporate a laser on the optical clock module. A laser is capable of producing electromagnetic radiation; therefore, you must follow laser safety procedures when working with the optical clock module.

Lasers are classified by the level of radiation accessible to humans during the operation of the laser or laser product. Table 3 lists the different laser classes and describes their wavelength range and optical power accession limits. The accession limit is the maximum rating or sudden outburst possible from the specified laser class. Note that a Class I laser is the safest type of laser or laser product.

Table 3. Laser Classes

Class	Wavelength Range	Accession Limits
I	180 nm to 10^6 nm	Varies with λ and exposure time
Ila	400 nm to 710 nm	3.9×10^{-6} W (3.9 microwatts)
II	400 nm to 710 nm	1.0×10^{-3} (1.0 milliwatt)
IIla	400 nm to 710 nm	5.0×10^{-3} (5.0 milliwatts)
IIlb	180 nm to 400 nm	Varies with λ and exposure time
	400 nm to 10^6 nm	0.5 watt

The lasers on the optical clock module are Class IIlb lasers; the manufacturer establishes this classification. However, when Cray Research, Inc. (CRI) incorporates these lasers into the CRAY T90 systems, the laser product (or CRAY T90 system) is considered a Class I laser product. This is because the classification is determined by the amount of radiation exposure during system operation. During the operation of a CRAY T90 system, all of the laser light is confined to the fiber-optic waveguides in the system. No laser light radiates outside of these fiber-optic waveguides; therefore, no laser light radiates outside of the mainframe cabinet.

NOTE: If a CRAY T932 system is degraded for maintenance purposes, the degraded portion of the system still receives the clock signal. Be sure to follow all laser safety procedures when replacing modules or performing system maintenance on a degraded CRAY T932 system.

If you ever apply power to the optical clock module when it is not enclosed in the mainframe cabinet (STCO and Engineering only), or if you are maintaining a degraded CRAY T932 system, be sure to follow these guidelines to ensure safety:

- Read and follow the information on all caution/warning/danger labels before applying power to the module. Figure 7 illustrates a sample caution label for a laser product.

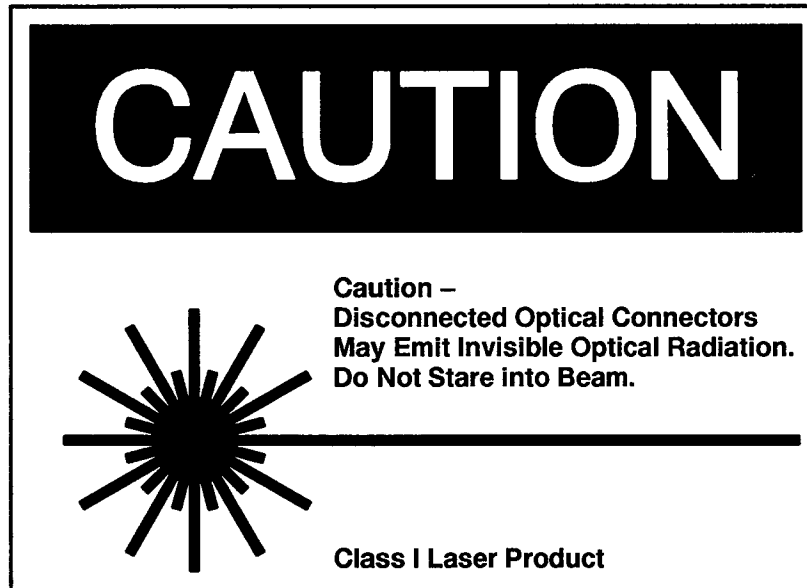
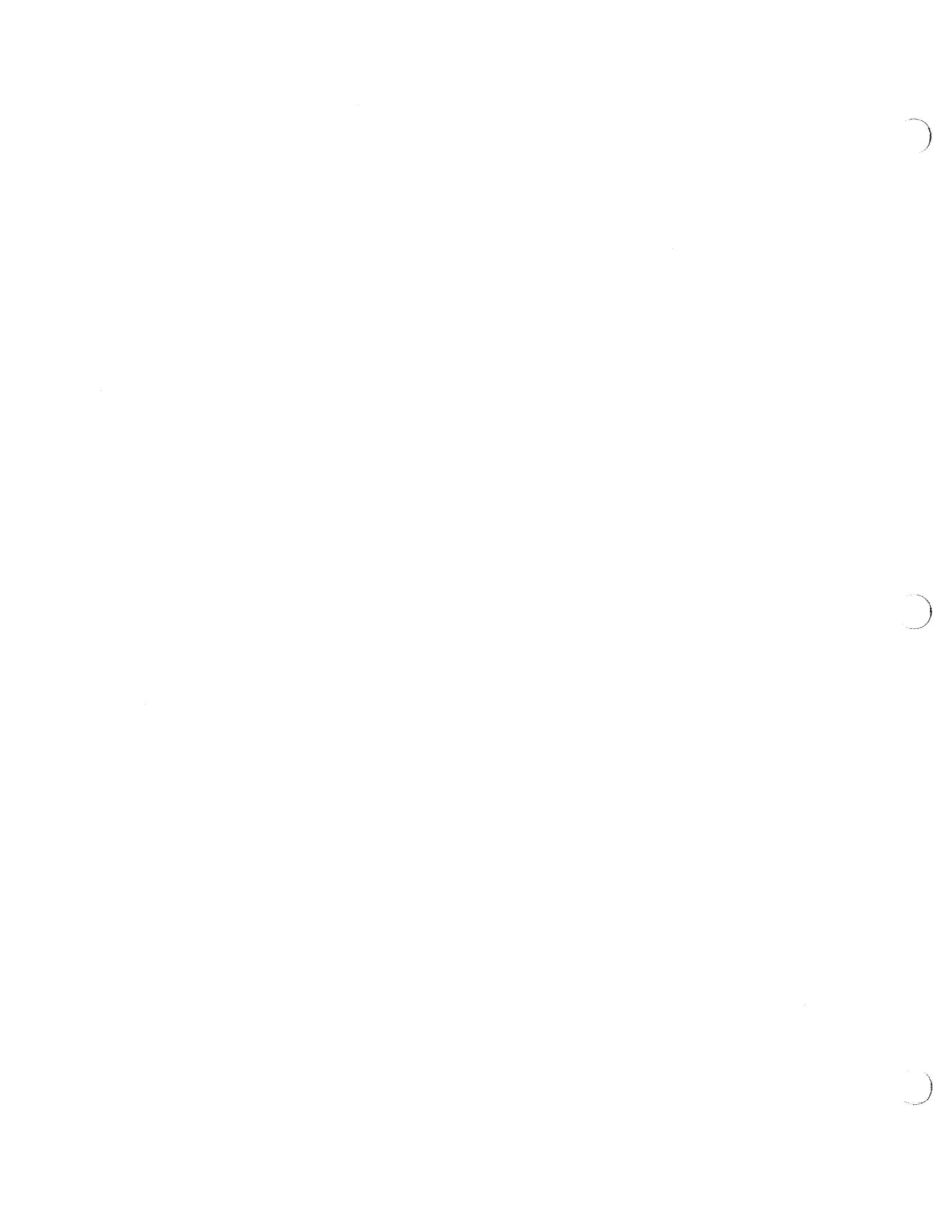

Figure 7. Sample Caution Label for a Class I Laser Product

- Be sure that safety goggles or eye protection is effective at the wavelength(s) emitted by the optical clock module before applying power to the module.
- Always attach the connector to the fiber before applying power to the module. This ensures that all light is confined within the fiber-optic waveguide, practically eliminating any potential hazard.
- Never look into the end of a fiber to see whether light is being emitted. Most fiber-optic laser wavelengths (1300 nm and 1550 nm) are invisible to the eye and will cause permanent damage. Shorter wavelength lasers (for example 780 nm) are visible and are very damaging. Always use an optical power meter to verify light output.

- Never look into the end of a fiber on a powered device with any type of magnifying device such as a microscope, eye loupe, or magnifying glass. This will cause a permanent, irreversible burn on your retina.
- Call the manufacturer with any questions about laser safety before applying power to the optical clock module.

If you are ever exposed to or injured from laser radiation, be sure to fill out a Health Incident Report and submit it (within 24 hours of the incident) to the Health/Safety/Environment department in Chippewa Falls, Wisconsin.



Reader Comment Form

Title: Optical Clock Module
Preliminary Information

Number: HTM-xxx-0
August 1994

Your feedback on this publication will help us provide better documentation in the future. Please take a moment to answer the few questions below.

For what purpose did you primarily use this document?

Troubleshooting
 Tutorial or introduction
 Reference information
 Classroom use
 Other - please explain _____

Using a scale from 1 (poor) to 10 (excellent), please rate this document on the following criteria and explain your ratings:

Accuracy _____
 Organization _____
 Readability _____
 Physical qualities (binding, printing, page layout) _____
 Amount of diagrams and photos _____
 Quality of diagrams and photos _____

Completeness (Check one)

Too much information _____
 Too little information _____
 Just the right amount of information

Your comments help Hardware Publications and Training improve the quality and usefulness of your publications. Please use the space provided below to share your comments with us. When possible, please give specific page and paragraph references. We will respond to your comments in writing within 48 hours.

NAME _____
JOB TITLE _____
FIRM _____
ADDRESS _____
CITY _____ STATE _____ ZIP _____
DATE _____

[or attach your business card]

CRAY
RESEARCH, INC.

CUT ALONG THIS LINE

Fold



NO POSTAGE
NECESSARY
IF MAILED
IN THE
UNITED STATES

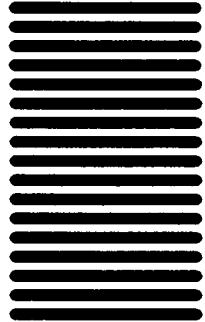

BUSINESS REPLY CARD

FIRST CLASS PERMIT NO 6184 ST. PAUL, MN

POSTAGE WILL BE PAID BY ADDRESSEE



**Attn: Hardware Publications and Training
890 Industrial Boulevard
Chippewa Falls, WI 54729**

Fold

STAPLE

LASER Board

OSCILLATOR Board

LP01 or HP01

OSC4

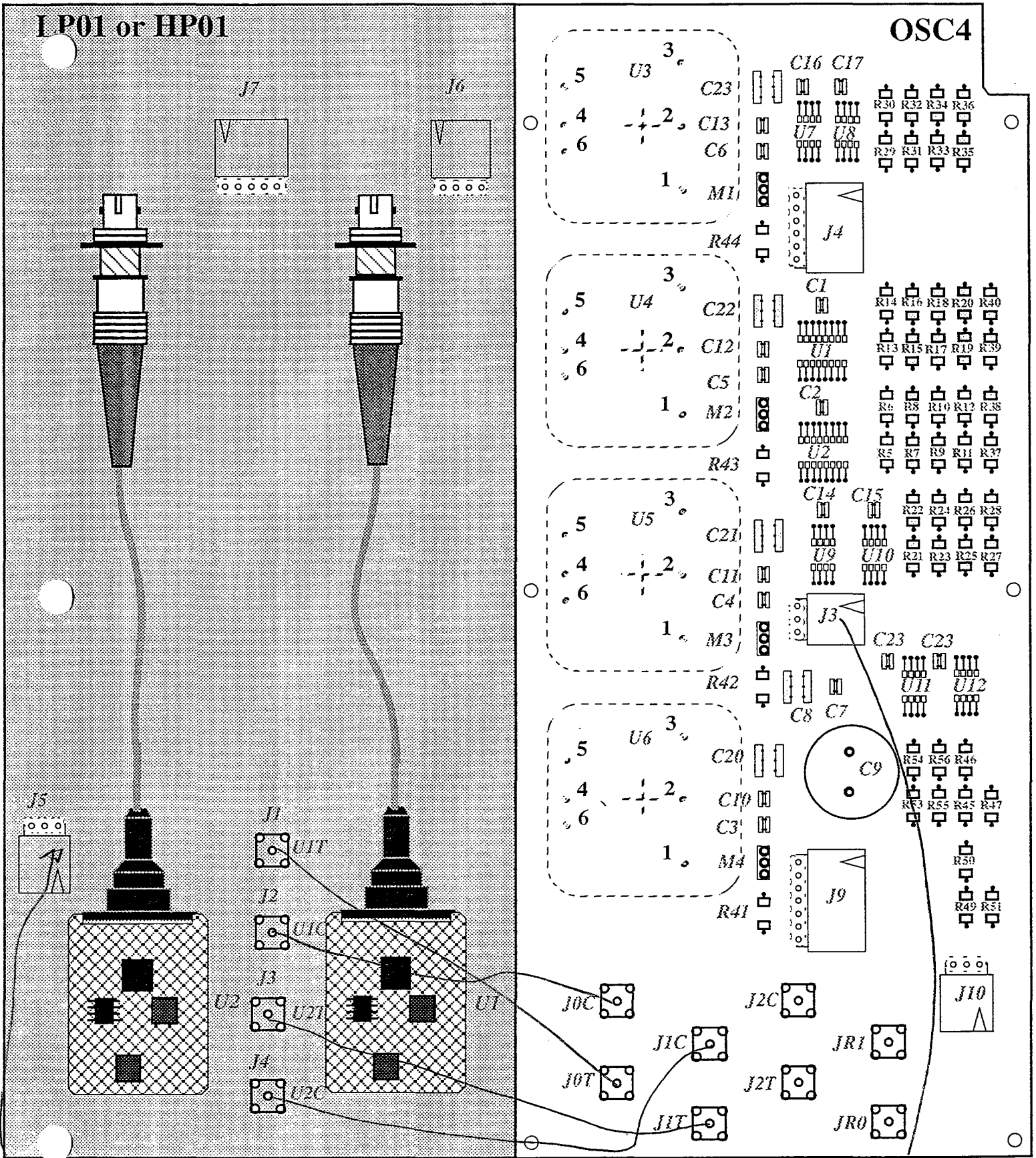

**WIRING OF THE CLOCK MODULE,
LASER BOARD TO OSC4**

- 1 - Attach 3 pin molex jumper from connector LP01_J5 to connector OSC4_J10.**
- 2 - Attach SMA coaxial jumper from connector LP01_J1 to connector OSC4_J0T.**
- 3 - Attach SMA coaxial jumper from connector LP01_J2 to connector OSC4_J0C.**
- 4 - Attach SMA coaxial jumper from connector LP01_J3 to connector OSC4_J1T.**
- 5 - Attach SMA coaxial jumper from connector LP01_J4 to connector OSC4_J1C.**