

CRAY J90™ Series ATM-1V Upgrade Procedure

HMU-163-0

Cray Research Proprietary

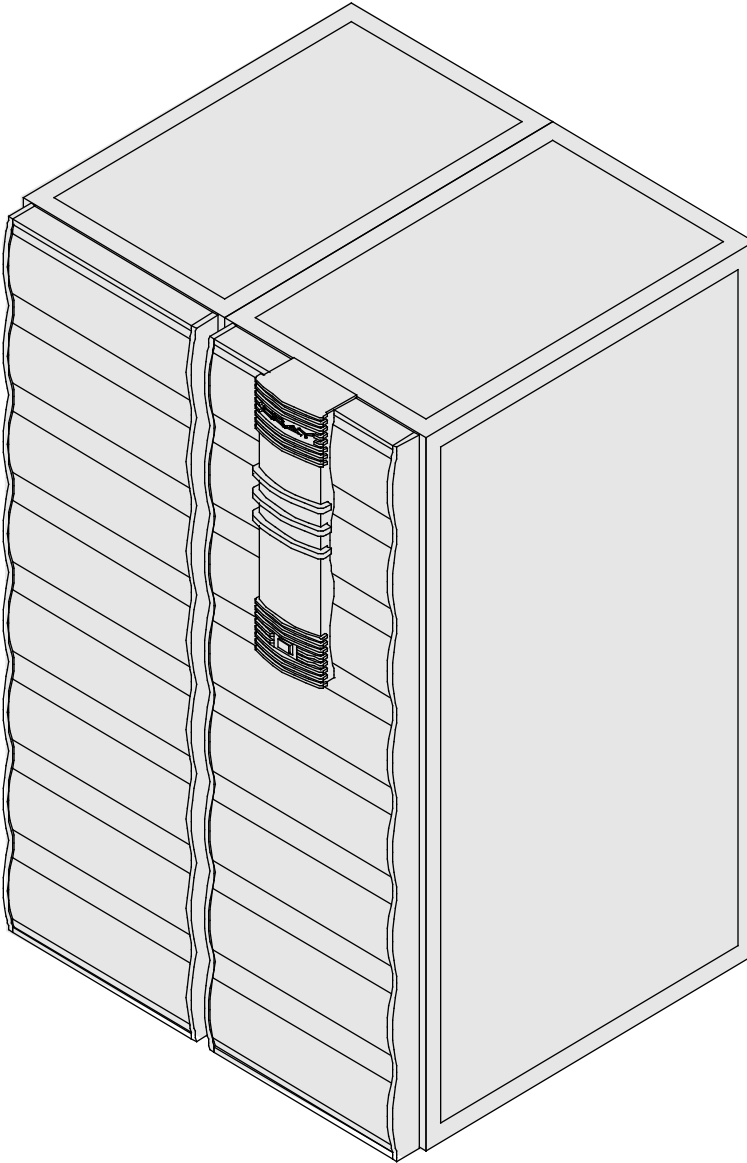

Cray Research, Inc.

Record of Revision

REVISION	DESCRIPTION
----------	-------------

April 1996. Original version that includes the Interphase ATM card.

Any shipment to a country outside of the United States requires a letter of assurance from Cray Research, Inc.
--

This document is the property of Cray Research, Inc. The use of this document is subject to specific license rights extended by Cray Research, Inc. to the owner or lessee of a Cray Research, Inc. computer system or other licensed party according to the terms and conditions of the license and for no other purpose.

Cray Research, Inc. Unpublished Proprietary Information — All Rights Reserved.

Autotasking, CF77, CRAY, CRAY-1, Cray Ada, CraySoft, CRAY Y-MP, HSX, LibSci, MPP Apprentice, SSD, SUPERCLUSTER, SUPERSERVER, UniChem, UNICOS, and X-MP EA are federally registered trademarks and Because no workstation is an island, CCI, CCMT, CF90, CFT, CFT2, CFT77, ConCurrent Maintenance Tools, COS, CRAY-2, Cray Animation Theater, CRAY APP, CRAY C90, CRAY C90D, Cray C++ Compiling System, CrayDoc, CRAY EL, CRAY J90, Cray NQS, Cray/REELlibrarian, CRAY S-MP, CRAY SUPERSERVER 6400, CRAY T3D, CRAY T3E, CRAY T90, CrayTutor, CRAY X-MP, CRAY XMS, CRInform, CRI/TurboKiva, CS6400, CSIM, CVT, Delivering the power . . ., DGauss, Docview, EMDS, GigaRing, HEXAR, IOS, ND Series Network Disk Array, Network Queuing Environment, Network Queuing Tools, OLNET, RQS, SEGLDR, SMARTE, SUPERLINK, System Maintenance and Remote Testing Environment, Trusted UNICOS, UNICOS MAX, and UNICOS/mk are trademarks of Cray Research, Inc.

Requests for copies of Cray Research, Inc publications should be directed to:

CRAY RESEARCH, INC.
Logistics
1100 Lowater Road
Chippewa Falls, WI 54729

Comments about this publication should be directed to:

CRAY RESEARCH, INC.
Service Publications and Training
890 Industrial Blvd.
Chippewa Falls, WI 54729

CRAY J90 SERIES ATM-1V UPGRADE PROCEDURE

Device to Be Upgraded	3
Description of Upgrade	3
ATM-1V Upgrade Prerequisites	3
Training Requirements	3
ESD Precautions	3
ESD Smock	4
Wrist Strap	4
Reference Publications	4
Estimated Time to Install Upgrade	5
Parts Required	5
Tools Required	5
Software Required	5
Conventions	6
Getting Started	6
Create a Backup Copy of the UNICOS File System	6
Modify the IOS Configuration File	6
Configure the VME Interface	7
Files Changed by ICMS	18
/etc/config/param File	19
/etc/config/atm.pvc File	21
/etc/hosts File	22
/etc/networks File	22
/etc/config/interfaces File	23
Installing the VME Hardware	24
Power Down the CRAY J90 Series System	25
Open the CRAY J90 Series I/O Cabinet Rear Door	26
Open the CRAY J90 Series I/O Cabinet Front Door	26
Install the ATM-1V Controller	26

Install VME Bulkhead Plate	28
Connect ATM-1V Controller Cables	28
Install I/O Bulkhead Plate and Connectors	29
Connect Intermediate Cable to VME Bulkhead	30
Disconnect all Cables from VME Bulkhead	30
Route Cables through Cable Tray and Flexible Cable Way	33
Connect the Multimode 3-meter Cables to the I/O Bulkhead	34
Replace VME Tray	34
Close the CRAY J90 Series I/O Cabinet Front Door	34
Close the CRAY J90 Series I/O Rear Cabinet Door	35
Power Up the CRAY J90 Series System	35
Loading the IOS and Booting the System	35
Testing the ATM-1V Upgrade	36
Configure Up TCP/IP for the VME Interfaces	38
Debugging a VME Problem	38
Removed Parts Disposition	38
Cruise Reporting	38

Figures

Figure 1. ATM-1V Jumper Settings	27
Figure 2. VME Bulkhead (Back View)	28
Figure 3. I/O Bulkhead	29
Figure 4. ATM-1V Bulkhead Connector Assembly	30
Figure 5. Flexible Cable Way	32
Figure 6. Flexible Cable Way Crossbars	33

Tables

Table 1. Estimated Times to Install Upgrade	5
Table 2. ATM-1V Upgrade Kit Contents (P/N 90446600) .	5

Device to Be Upgraded

This document contains procedures on how to add an Interphase ATM-1V asynchronous transfer mode (ATM) controller to a CRAY J90 series system.

Description of Upgrade

Cray Research customers have the option of implementing ATM in their CRAY J90 series systems. This procedure is written to aid CRI support personnel in the task of installing, configuring, and testing an ATM-1V.

This procedure includes only information for installing an Interphase ATM controller.

ATM-1V Upgrade Prerequisites

The following list describes some special configuration considerations:

- It is recommended that a full backup of existing file systems be completed before this upgrade is started
- UNICOS 8.0.4.2 release or above. The ATM driver is not supported on any earlier releases.

Training Requirements

Cray Research personnel who perform this upgrade must have completed training in CRAY J90 series hardware and system administration. If this is not possible, a hardware-trained person must have a system administrator available during this upgrade. Experience in upgrading or installing the UNICOS operating system on a CRAY J90 series system or CRAY Y-MP EL system is advised.

ESD Precautions

Observe ESD precautions during the entire upgrade process. Required apparel includes an ESD smock and an ESD wrist strap. Do not wear watches or jewelry when you work on a CRAY J90 series system cabinet.

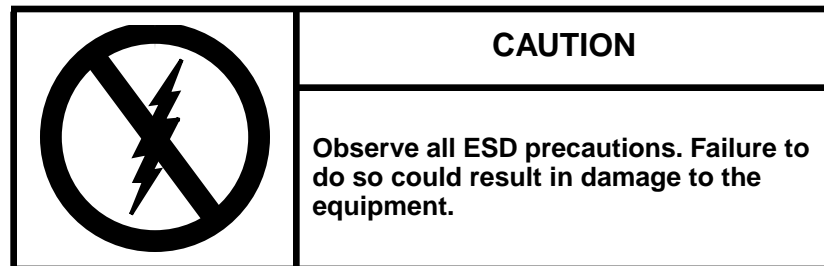

ESD Smock

Wear a Cray Research-approved static-dissipative smock when servicing or handling an ESD-sensitive device. Completely button the smock and wear it as the outermost layer of clothing. You must have a portion of the smock's sleeves in direct contact with the skin of your arms. Skin contact is essential for a dissipative path-to-earth ground through your wrist strap. Tuck hair that exceeds shoulder length inside the back of the smock.

Wrist Strap

Wear a Cray Research-approved wrist strap when handling an ESD-sensitive device to eliminate possible ESD damage to equipment. Connect the wrist strap cord directly to earth ground.

Reference Publications

- *UNICOS Basic Administration Guide for CRAY J90 and CRAY EL Series*, Cray Research publication number SG-2416
- *CRAY IOS-V Commands Reference Manual*, Cray Research publication number SR-2170
- *CRAY IOS-V Messages*, Cray Research publication number SQ-2172
- *CRAY J916 Service Manual Kit*, Cray Research publication number HMK-101-0
- *UNICOS Installation and Configuration Tool Reference Manual*, publication number SR-3090
- *UNICOS Installation/Configuration Menu System User's Guide*, publication SG-2412

Estimated Time to Install Upgrade

Table 1 divides the ATM-1V upgrade process into three separate procedures. Use this table to determine how much system time you should request to complete this upgrade.

NOTE: It is recommended that you contact the customer and request that he or she complete a full backup prior to this upgrade.

Table 1. Estimated Times to Install Upgrade

Installation Task	Estimated Time to Install Upgrade
Software Configuration and Verification	1.5 hours
Hardware Installation	1 hour
Hardware Verification Testing	0.5 hour

Parts Required

Table 2. ATM-1V Upgrade Kit Contents (P/N 90446600)

CRI Part number	Quantity	Description
90446700	1	Module Assembly, ATM-1V
90446400	1	Cable Assembly, AT-1, 20-in. Fiber Optics
90446900	1	Plate Assembly, Bulkhead ATM, BNC
90369300	1	Cable Assembly, Multimode, FDDI 3 Meters
90447000	1	Adapter, Bulkhead, SC-ST
90447100	1	Plate Assembly, Bulkhead. ATM Connector
90047005	2	Screw, Panhead Phillips 2-56X3/16SS
90452200	1	Connector, Loopback, SC Low Loss
90030500	10	Cable Tie, Mounting Nylon 4 inches

Tools Required

The majority of tools required for performing upgrades are common hand-held tools that are included with the Customer Service toolkit.

Software Required

- Minimum IOS kernel revision - 1.7
- Minimum UNICOS revision - 8.0.4.2
- No special considerations

Conventions

The following conventions are used throughout this document:

<u>Convention</u>	<u>Meaning</u>
command	This fixed-space font denotes literal items such as commands, files, routines, path names, signals, messages, and programming language structures.
manpage(<i>x</i>)	Man page section identifiers appear in parentheses after man page names.
<i>variable</i>	Italic typeface denotes variable entries, words or concepts being defined.
user input	This bold fixed-space font denotes literal items that the user enters in interactive sessions. Output is shown in nonbold, fixed-space font.
<KEY>	This convention indicates a key on the keyboard.

Getting Started

Check off each step as you complete it.

Create a Backup Copy of the UNICOS File System

It is recommended that you create a backup copy of the UNICOS file system before you proceed with the upgrade procedures. Refer to the *UNICOS Basic Administration Guide for CRAY J90 and CRAY EL Series*, publication number SG-2416, for details on how to create a backup copy of the UNICOS file system.

Modify the IOS Configuration File

In any window on the workstation, edit the IOS configuration file and add the IOS ATM driver to the appropriate IOS files, as follows:

```
# vi /opt/ios/9xxx/config
```

The following code shows an example of the added IOS ATM driver to the IOS system named IOS1 in the configuration file:

```
IOS1: 2093 1228800
#-----
#Device driver name
#-----
/dev/disk
/dev/ipi
/dev/esdi
/dev/atmi
```

Configure the VME Interface

This subsection describes the steps needed to configure the VME interface by using the UNICOS Installation / Configuration Menu System (ICMS). For information on how to use the ICMS, refer to the *UNICOS Installation/Configuration Menu System User's Guide*, publication SG-2412, and the *UNICOS Installation and Configuration Tool Reference Manual*, publication SR-3090.

When you configure the VME interface in the UNICOS operating system, you will be updating the following files:

- /etc/config/param
- /etc/config/atm.pvc
- /etc/hosts
- /etc/networks
- /etc/config/interfaces

Details on the changes made to these files are provided in the “Files Changed by ICMS” subsection, [page 18](#).

NOTE: Because some of the menus are associated with other configuration files, files other than ones previously listed will be updated. If the UNICOS Installation/Configuration Menu System resembles your system's configuration, everything will be updated appropriately. If your system's configuration does not match the UNICOS Installation/Configuration Menu System, perform [Step 3](#) through [Step 8](#) starting on [page 8](#).

To configure the VME interface by using the ICMS, perform the following steps:

1. Log in as `root`.
2. Enter the UNICOS Installation/Configuration Menu System by entering the following command on the system console:

```
# /etc/install/install
```

3. Once you are in the ICMS, it is recommended that you use the `import` utility to update the system configuration before you configure anything. To import the current system configuration into the menu system, go to the Import Options option, as shown:

```
UNICOS Installation/Configuration Menu System
.  Utilities
.  .  Import Utility
.  .  .  Import Options
```

4. Set the import options to the following values

```
Import Options
S->  Import root mount point
      Stop import on error?      YES
      Import host or guest versions?  host
      Reload default import table ...
```

5. After selecting the Import Options, select `e`.

NOTE: It is important to import files used by the site ([Step 6](#)) to ensure that any changes initiated outside of the tool get included before changes made for ATM are activated.

6. Exit the Import Options option and select the Import Table option, as shown:

```
UNICOS Installation/Configuration Menu System
.  Utilities
.  .  Import Utility
.  .  .  Import Table
```

The configuration files associated with ATM must be imported. Set to `NO` any Import Table option that your site does not use. Set the following Import Table options to `YES`:

Import Table					
Class	Description	Import?	Program	Options	
----	-----	-----	-----	-----	
E->	HARDWARE	Param	YES	hdwparam.sh	-i \$RELEA
	KERNEL	Config.h uts	YES	utsconfh.sh	-i \$RELEA
	KERNEL	Param uts	YES	utsparam.sh	-i \$RELEA
	KERNEL	Comm channels	YES	utscparam.sh	-i \$RELEA
	HOSTS	Hosts	YES	utlimp.sh	hosts
	NETWORKS	Networks	YES	utlimp.sh	networks
	NETIF	Network Interfaces	YES	netifs.sh	-i

7. Exit the Import Table option by selecting e, and select the Import Utility option, as shown:

```

UNICOS Installation/Configuration Menu System
.  Utilities
.  .  Import Utility
    
```

Set the Import class to run option to ALL, as follows:

```

Import Utility
Import options ==>
M-> Import table ==>
Import class to run
ALL
Run the import process ...
    
```

8. Execute the Run the import process option. This option overwrites the menu system database. Exit the Import Utility option and answer y (yes) to the following question:

```

Do you want to continue? y
    
```

9. Go to the Native ATM Configuration option, as shown:

```

UNICOS Installation/Configuration Menu System
.  Configure System
.  .  Kernel Configuration
.  .  .  Communication Channel Configuration
.  .  .  .  Native ATM Device Configuration
    
```

Enter the appropriate parameters to build the atmdev entries in the /etc/config/param file, as in the following example:

```

Native ATM Configuration
-> ATM device ordinal 0
    I/O cluster number 0
    IOP number         0
    IOP Channel number 020

```

The following list describes the parameters:

<u>Parameter</u>	<u>Description</u>
ATM device ordinal	Specifies the VME interface that will be defined in the param file. Possible values are 0 through 15.
I/O cluster number	Specifies the IOS in which the ATM module will reside. Possible values are 0 through 15.
IOP number	Value must be 0.
IOP channel number	Specifies the channel number that the I/O processor (IOP) uses to communicate with the ATM controller in the IOS. A maximum of two ATM controllers are allowed per IOS. Use channel 20 octal for the first ATM controller and channel 21 octal for the second.

Create entries for all VME interfaces that are being installed.

- Exit the Native ATM Configuration option and answer y (yes) to the following question:

```
Do you want to update form file? (y/n): y
```

- To configure the VME interfaces, go to the Network Parameters option, as shown:

```

UNICOS Installation/Configuration Menu System
.   Configure System
.   .   Kernel Configuration
.   .   .   Network Parameters

```

To update the `/etc/config/param` file, enter the appropriate network parameters, as shown in the following example:

Network Parameters	
Number of TCP memory buffers (TCP_NMBSPACE)	4000
Max. Native ATM network devices (atmmxdevs)	2
ATM ARP receive space (atmarp_recv)	131072
ATM ARP send space (atmarp_send)	65536
Max. ATM ARP entries (atmarp_entries)	1024

The following list describes the parameters:

<u>Parameter</u>	<u>Description</u>
Number of TCP memory buffers (TCP_NMBSPACE)	Specifies the number of mbufs to be defined for the system. This value is system-dependent.
Max. Native ATM network devices (atmmxdevs)	Specifies the maximum number of ATM modules allowed for this system. Valid values are 1 through 16. Set this value to the number of ATM interfaces to be installed in this system.
ATM ARP receive space (atmarp_recv)	Specifies the amount of socket receive space used by the atmarp(1) command. This value should always be a power of 2. The default value of 131072 should be sufficient for most systems.
ATM ARP send space (atmarp_send)	Specifies the amount of socket send space used by the atmarp(1) command. This value should always be a power of 2. The default value of 65536 should be sufficient for most systems.
Max. ATM ARP entries (atmarp_entries)	Specifies the maximum number of address resolution protocol (ARP) entries allowed in the ATM ARP table. The default value of 1024 should be sufficient for most systems. This value is directly related to the number of remote hosts that communicate through the ATM.

12. To activate the kernel configuration, go to the Activate the Kernel Configuration option, as shown:

```

UNICOS Installation/Configuration Menu System
.   Configure System
.   .   Kernel Configuration
.   .   .   Activate the Kernel Configuration

```

Answer y (yes) to the following question:

Do you want to proceed with the configuration update? **y**

You need to complete the next two steps only if you will be configuring Permanent Virtual Circuits (PVCs) for remote hosts with which this system will communicate through the VME interface. PVCs provide a means to state a path to a remote host specifically. PVCs are created and deleted by using the `atmarp(8)` command. The next two steps configure the parameters that will be used by the `atmarp(8)` command.

NOTE: Switched Virtual Circuit (SVC) support is under development and will be added to the UNICOS system at a later release. SVCs are a dynamic way to create a path to a remote host. SVCs use a protocol called *signaling* to set up and delete an available path between two hosts. The software performs SVCs automatically.

13. Exit the Activate the Kernel Configuration option by entering e, and go to the Permanent Virtual Circuit Configuration option, as shown:

```

UNICOS Installation/Configuration Menu System
.   Configure System
.   .   Network Configuration
.   .   .   Native ATM Configuration
.   .   .   .   Permanent Virtual Circuit Configuration

```

To update the `/etc/config/atm.pvc` file, use the n key to enter the Permanent Virtual Circuits (PVCs) for all remote hosts with which this system will communicate through the VME interface. The following text is an example of a `/etc/config/atm.pvc` file:

Permanent Virtual Circuit Configuration						
	Remote Hostname	Interface	AAL	VPI	VCI	QOS (Kb/s)
	-----	-----	---	---	---	-----
E->	remotehost_atm0	atm0	5	0	32	1
	remotehost_atm1	atm1	5	0	33	1

Following is a description of the parameters:

<u>Parameter</u>	<u>Description</u>
Remote Hostname	Specifies the IP host name of the remote host. This name must be located in the <code>/etc/hosts</code> file.
Interface	Specifies the name of the VME interface that this system will use to reach the remote host. The name is as it appears in the output of the <code>netstat -i</code> command.
AAL	Specifies the ATM Adaptation Layer (AAL) to be used by this PVC. This value is based on ATM standards. Currently, the ATM connection supports only AAL 5. Specify this number in decimal form.
VPI	Specifies the Virtual Path Identifier (VPI). The VPI is placed into each ATM cell header so that the cell can be routed through the ATM network. Currently, ATM interfaces support only VPI 0. Specify this number in decimal form.
VCI	Specifies the Virtual Channel Identifier (VCI). The VCI is placed into each ATM cell header so that the cell can be routed through the ATM network. This number should be between 32 and 1023. Consult your local network administrator when determining the VCI. Specify this number in decimal form.
QOS (Kb/s)	Specifies the quality of service expressed in kilobits per second. This is the peak data rate at which this host will deliver ATM cells to the remote host through the ATM interface. Placing a 0 in this field causes the peak rate control feature to be disabled when sending to this remote host, thus allowing unlimited bandwidth. Specify this number in decimal form.

14. Exit the Permanent Virtual Circuit Configuration option by entering e, and answer y (yes) to the following question:

Do you want to update form file? (y/n): **y**

15. To activate the VME (Native ATM) configuration, go to the Activate the Native ATM Configuration option, as shown:

```
UNICOS Installation/Configuration Menu System
.   Configure System
.   .   Network Configuration
.   .   .   Native ATM Configuration
.   .   .   .   Activate the Native ATM Configuration
```

Answer y (yes) to the following question:

Do you want to proceed with the configuration update? **y**

16. Exit the Activate the Native ATM Configuration option by entering e, and go to the Host Address Configuration option, as shown:

```
UNICOS Installation/Configuration Menu System
.   Configure System
.   .   Network Configuration
.   .   .   General Network Configuration
.   .   .   .   Host Address Configuration
```

To update the /etc/hosts file, use the n key to configure the VME connection for TCP/IP. The following screen is an example of a /etc/hosts file:

Host Address Configuration			
Proto	Name	Address	Comment
-----	----	-----	-----
inet	edge_atm0	128.162.102.25	
inet	remotehost_atm0	128.162.102.30	
inet	remotehost_atm1	128.162.102.31	

The following list describes the configuration parameters:

<u>Parameter</u>	<u>Description</u>
Proto	Specifies the Internet protocol
Name	Specifies the IP address alias
Address	Specifies the standard IP address value

17. To update the `/etc/networks` file, go to the Network Address Configuration option, as shown:

```

UNICOS Installation/Configuration Menu System
.   Configure System
.   .   Network Configuration
.   .   .   General Network Configuration
.   .   .   .   Network Address Configuration

```

Configure the ATM Internet network address for TCP/IP by creating an entry in the `/etc/networks` file for each ATM network. There will be a network address for each ATM interface that will communicate through TCP/IP. The following screen is an example of a `/etc/networks` file:

Network Address Configuration				
	Proto	Name	Address	Comment
	-----	----	-----	-----
E->	inet	atmnet	128.162.102	

The following list describes the configuration parameters:

<u>Parameter</u>	<u>Description</u>
Proto	Specifies the Internet protocol
Name	Specifies the IP address alias
Address	Specifies the standard IP address value

18. Exit the Network Address Configuration option by entering `e`, and go to the Network Interface Configuration option, as follows:

```

UNICOS Installation/Configuration Menu System
.   Configure System
.   .   Network Configuration
.   .   .   General Network Configuration
.   .   .   .   Network Interface Configuration

```

To update the `/etc/config/interfaces` file, use the `n` key to enter the appropriate information to automatically configure up the VME interface during a UNICOS boot for this system, as shown in the following example:

Network Interface Configuration							
Name	Hycf	Family	Address	Dest	Subnet	Type	Bcst
----	----	-----	-----	----	-----	----	----
lo0		inet	localhost				
en0		inet	edge.cray.com		0xffffffff00		
fddi0		inet	edge-fddi.cray.com		0xffffffff00		128.16
E-> atm0		inet	edge-atm0		0xffffffff00	pvc	

The following list describes the configuration parameters:

<u>Parameter</u>	<u>Description</u>
Name	Specifies the interface name and ordinal of the ATM interface to be configured. The syntax is atm x , where x is the ordinal number of the ATM interface.
Hycf	Not used.
Family	Must be set to inet.
Address	Specifies the IP host address for this interface connection. This parameter must be defined in the <code>/etc/hosts</code> file.
Dest	Specifies the destination (point-to-point) address. It is not needed for the ATM connection.
Subnet	Specifies the subnetwork address mask to be used for this interface.
Type	Specifies the interface type, used to select the type of signaling to be used across the ATM network. These values also imply the type of encapsulation used for IP datagrams. The following types are supported: <ul style="list-style-type: none"> • <code>pvc</code> - Permanent Virtual Circuit. Implies 802.2 LLC encapsulation. • <code>spans</code> - Simple Protocol for ATM Network Signaling (SPANS) protocol. Implies null encapsulation and Switched Virtual Circuits (SVC).

<u>Parameter</u>	<u>Description</u>
	<ul style="list-style-type: none"> q2931 - Q2931 is the Switched Virtual Circuit standard. This is under development and does not currently work. Implies 802.2 LLC encapsulation and Switched Virtual Circuits (SVC). <p>NOTE: If the interface type is set to pvc, signaling will not be performed on that interface. However, if an interface is marked as spans or q2931, PVCs are still supported on that interface when you use the atmarp command to place them in the atmarp table.</p>
Bcst	Specifies broadcast address.

19. Exit the Network Interface Configuration option by entering e, and answer y (yes) to the following question:

```
Do you want to update form file? (y/n): y
```

20. Go to the General Network Configuration option, as follows:

```
UNICOS Installation/Configuration Menu System
.   Configure System
.   .   Network Configuration
.   .   .   General Network Configuration
```

21. Activate general network configuration, as follows:

```
General Network Configuration
Host address configuration ==>
Network address configuration ==>
Networking services configuration ==>
Network hardware address configuration ==>
Network interface configuration ==>
Import general network configuration ==>
A-> Activate general network configuration
```

Answer y (yes) to the following question:

```
Do you want to proceed with the configuration update? y
```

22. Copy the param file to the console disk by selecting the Expander File Transfers menu, as follows:

```

UNICOS Installation/Configuration Menu System
.   Utilities
.   .   File Transfer Utilities

```

23. Verify that the following parameters are configured to transfer the /etc/config/param file to the console disk:

```

Expander File Transfers

```

```

S->Transfer UNICOS kernel to the expander? NO
Transfer CSL param file to the expander? YES

```

```

Expander directory name           sys
Expander file name suffix

```

```

Do the transfer to the expander . . .

```

24. Execute the transfer by selecting the following option:

```

A-> Do the transfer to the expander ...

```

25. Exit the UNICOS Installation/Configuration Menu System by typing q (quit) and answering y (yes) to the following question:

```

Do you want to quit? y

```

For examples of the files that have been updated by the preceding process, refer to the following subsections.

Files Changed by ICMS

The following subsections describe and show examples of the files that are updated when you configure the VME interface by using the ICMS. The examples in the following subsections show only the part of the files that relate to the ATM interface configuration. Exact parameter settings will be system-dependent.

The following files are updated:

- /etc/config/param
- /etc/config/atm.pvc
- /etc/hosts

- /etc/networks
- /etc/config/interfaces

/etc/config/param File

The /etc/config/param file contains the parameters needed to configure the VME interface for the host system.

In the `network` section of the file, you must create entries for all VME interfaces that are being installed. Enter appropriate values for the following parameters:

<u>Parameter</u>	<u>Description</u>
<code>tcp_nmbspace</code>	Number of TCP memory buffers. Specifies the number of mbufs to be defined for the system. This value is system-dependent.
<code>atmmxdevs</code>	Maximum VME (Native ATM) network devices. Specifies the maximum number of VME modules allowed for this system. Valid values are 1 through 16. Set this value to the number of VME interfaces to be installed in this system.
<code>atmarp_recv</code>	ATM ARP receive space. Specifies the amount of socket receive space used by the <code>atmarp(1)</code> command. This value should always be a power of 2. The default value of 131072 should be sufficient for most systems.
<code>atmarp_send</code>	ATM ARP send space. Specifies the amount of socket send space used by the <code>atmarp(1)</code> command. This value should always be a power of 2. The default value of 65536 should be sufficient for most systems.
<code>atmarp_entries</code>	Maximum ATM ARP entries. Specifies the maximum number of address resolution protocol (ARP) entries allowed in the ATM ARP table. The default value of 1024 should be sufficient for most systems. This value is directly related to the number of remote hosts that communicate through the ATM.
<code>atmdev</code>	ATM device ordinal. Specifies the ATM interface that will be defined in the <code>param</code> file. Possible values are 0 through 15.

<u>Parameter</u>	<u>Description</u>
path	I/O path that consists of the following three parameters: cluster, eiop, and channel.
cluster	I/O cluster number. Specifies the IOS in which the ATM module will reside. Possible values are 0 through 15.
eiop	IOP number. This number will always be 0.
channel	IOP channel number. Specifies the channel number that the I/O processor (IOP) uses to communicate with the ATM module in the IOS. This number is unique to each IOS. Valid values for this field are octal 20 and octal 21. Use octal 20 for the first module and octal 21 for the second module.

The following screen is an example of a `/etc/config/param` file:

```
# /etc/config/param file
.
.
.
network {
    4000 tcp_nmbospace;
    2 atmmaxdevs;
    131072 atmarp_recv;
    65536 atmarp_send;
    1024 atmarp_entries;
.
.
.
atmdev 0 {
    iopath {
        cluster 0;
        eiop 0;
        channel 020;
    }
}
.
.
.
```

/etc/config/atm.pvc File

The `/etc/config/atm.pvc` file shows the Permanent Virtual Circuits (PVCs) for all remote hosts that will communicate to this system through the ATM interfaces.

Create the following parameters in the `/etc/config/atm.pvc` file:

<u>Parameter</u>	<u>Description</u>
<code>remote.host.name</code>	IP host name of the remote host. This name must be located in the <code>/etc/hosts</code> file.
<code>interface</code>	Name of the ATM interface that this system will use to reach the remote host. The name is as it appears in the output of the <code>netstat -i</code> command.
<code>AAL.number</code>	ATM Adaptation Layer (AAL) to be used by this PVC. This value is based on ATM standards. Currently, the ATM connection supports only AAL 5. Specify this number in decimal form.
<code>VPI.number</code>	Virtual Path Identifier (VPI), placed into each ATM cell header so that the cell can be routed through the ATM network. Currently, ATM interfaces support only VPI 0. Specify this number in decimal form.
<code>VCI.number</code>	Virtual Channel Identifier (VCI), placed into each ATM cell header so that the cell can be routed through the ATM network. This number should be between 32 and 1023. Consult your local network administrator when determining the VCI. Specify this number in decimal form.
<code>QOS.number</code>	Quality of service expressed in kilobits per second. This is the peak data rate at which this host will deliver ATM cells to the remote host through the ATM interface. Placing a 0 in this field causes the peak rate control feature to be disabled when sending to this remote host, thus allowing unlimited bandwidth. Specify this number in decimal form.

The following text is an example of a `/etc/config/atm.pvc` file:

```

#/etc/config/atm.pvc file

# hostname      ifc      AAL      VPI      VCI      QOS
# -----      ---      ---      ---      ---      ---
#
remotehost_atm0 atm0      5        0        32       0
remotehost_atm1 atm1      5        0        33       0

```

/etc/hosts File

The `/etc/hosts` file contains host names. Create the following parameters in this file:

<u>Parameter</u>	<u>Description</u>
address	Standard IP address value
name	IP address alias

The following screen is an example of a `/etc/hosts` file:

```

#/etc/hosts file

128.162.102.25      edge-atm0
128.162.102.30      remotehost_atm
128.162.102.31      remotehost_atm1

```

/etc/networks File

The `/etc/networks` file contains the name and address of your ATM network. Create the following parameters in this file:

<u>Parameter</u>	<u>Description</u>
name	IP address alias
address	Standard IP address value

The following screen is an example of a `/etc/networks` file:

```

#/etc/networks file

atm01      128.162.102
.
.
.

```

Create as many entries as there are VME ATM interfaces configured for TCP/IP.

`/etc/config/interfaces` File

The `/etc/config/interfaces` file contains the parameters required to configure up the ATM interface by using the `/etc/initif` script.

Create the following parameters in the `/etc/config/interfaces` file:

<u>Parameter</u>	<u>Description</u>
name	Interface name and ordinal of the ATM interface to be configured.
family	Interface family name. Must be set to <code>inet</code> .
IP.host_address	IP host address for this interface connection. This parameter must be defined in the <code>/etc/hosts</code> file.
subnet	Subnetwork address mask to be used for this interface.
interface.type	Interface type, used to select the type of signaling to be used across the ATM network. These values also imply the type of encapsulation used for IP datagrams. The following types are supported: <ul style="list-style-type: none"> • <code>pvc</code> - Permanent Virtual Circuit. Implies 802.2 LLC encapsulation. • <code>spans</code> - Simple Protocol for ATM Network Signaling (SPANS) protocol. Implies null encapsulation and Switched Virtual Circuits (SVCs).

<u>Parameter</u>	<u>Description</u>
	<ul style="list-style-type: none"> q2931 - Q2931 is the Switched Virtual Circuit standard. This is under development and does not currently work. Implies 802.2 LLC encapsulation and Switched Virtual Circuits (SVC). <p>NOTE: If the interface type is set to pvc, signaling will not be performed on that interface. However, if an interface is marked as spans or q2931, PVCs are still supported on that interface when you use the atmarp command to place them in the atmarp table.</p>

The following text is an example of a /etc/config/interfaces file:

```
#/etc/config/interfaces file
# File format is:
#
# name   hycf_file      family  address          pt-to-pt-dest    args:
#                                     netmask
#                                     iftype
#                                     broadcast
#                                     mtu
#                                     rbuf
#                                     wbuf
#                                     bg
#                                     hwloop
atm0    -               inet    edge-atm0 -      netmask 0xffffffff00 iftype pvc
```

Installing the VME Hardware

The installation of the VME hardware consists of the following procedures:

- Powering down and removing panels
- Setting the ATM-1V jumpers

NOTE: The labels on the ATM-1V cables have the following meanings:

Transmit [TX] = output
Receive [RX] = input

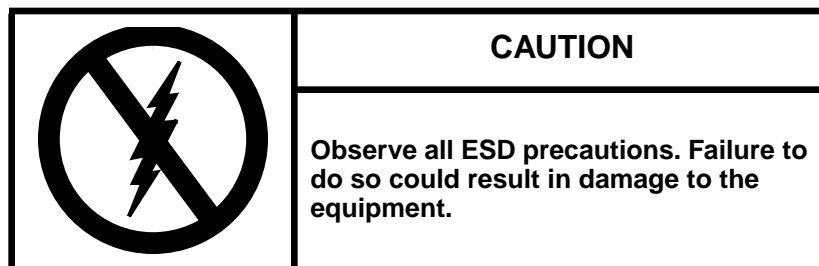

Power Down the CRAY J90 Series System

1. Ensure that the customer has brought the system to single-user mode.
2. Using the right mouse button, click on any open working space. The `Workspace` menu will appear.
3. From the `Workspace` Menu, select the `J90 Console` menu item.

NOTE: You must have superuser privileges to perform [Step 4](#).

4. Log into the UNICOS operating system by entering `<CONTROL-a>` to get a UNICOS prompt and enter the root login and password.
5. Shut down the UNICOS operating system by entering the following commands at a UNICOS prompt:

```
# cd /
# /etc/shutdown 120      (executes after 120 seconds)
# /bin/sync
# /bin/sync
# /bin/sync
# /etc/ldsync           (if you are using ldcache)
```

6. Stop the `J90 Console` connection by entering the following commands:

```
# <CONTROL-a>          (toggles to the IOS)
sn9xxx-ios0> mc
sn9xxx-ios0> reset     (takes 30 – 45 seconds to execute)
BOOT[sn9xxx-ios0]> ~. <CONTROL-c>
```

7. Open the mainframe cabinet front door by pushing down on the latch and swinging the door open.
8. Power off the system by pressing the `CCU SYSTEM OFF` button.

Open the CRAY J90 Series I/O Cabinet Rear Door

1. At the rear of the I/O cabinet, locate the two door-locking fasteners at the left top and left bottom of the door. Turn these fasteners 1/4-turn counterclockwise with a 5/32-in. allen wrench.
2. Grasp the door handle and swing the door open to the right.

Open the CRAY J90 Series I/O Cabinet Front Door

1. At the front of the I/O cabinet, locate the latch on the upper-right corner of the door.
2. Push down on the latch and swing the door open.

Install the ATM-1V Controller

Install the ATM-1V controller board into the correct IOS (depending on customer's system configuration) using the next available slot in that IOS.

1. Pull out the VME tray.
 - a. Remove the four screws that secure the VME tray to the cabinet.
 - b. Pull out the VME tray as far as it will go.
 - c. Release the screws that hold the top cover to the VME tray.
 - d. Remove the top cover from the VME tray and set it aside.
2. Unpack the new controller board if you are performing an upgrade.
3. Place the new board on an ESD-protected surface.
4. Change any jumpers or switches necessary on the new ATM-1V controller board. Refer to [Figure 1](#).
5. Select and remove the appropriate VME slot filler from the slot where the ATM-1V controller board will be installed.
6. Insert the ATM-1V controller board into the guide slots in the VME chassis.
7. Secure the ATM-1V controller board by tightening the screws to the VME chassis.

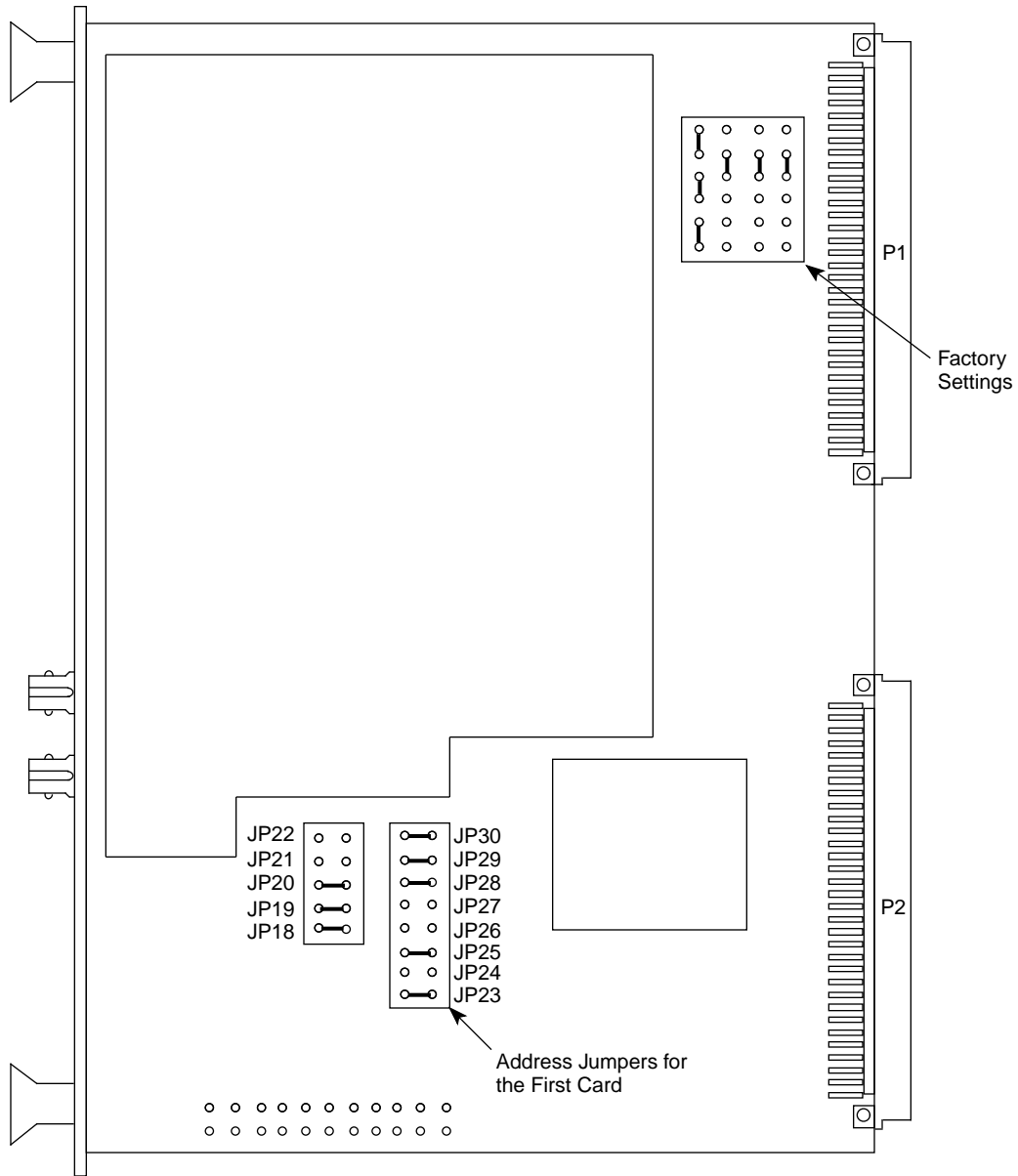

NOTE: Second and third ATM controller switch Settings in an IOS

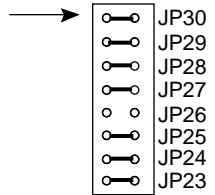
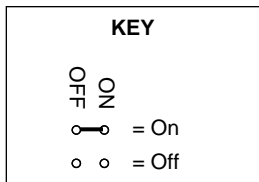

Second Card

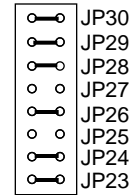

Third Card

Figure 1. ATM-1V Jumper Settings

Install VME Bulkhead Plate

Try to use a location on the bulkhead that is in line with the new ATM-1V controller in the IOS to minimize the crossing of cables.

1. Remove the appropriate blank bulkhead plate that is attached to the VME bulkhead by two screws. Refer to [Figure 2](#) for the location of the VME bulkhead.
2. Install the BNC bulkhead plate assembly (P/N 90446900); use the two screws that you removed in the previous step ([Step 1](#)). The upper connector on the plate is the transmit connector and the lower connector is the receive connection.

NOTE: Ensure that the plate's gasket is positioned away from the metal mesh of the adjacent plate.

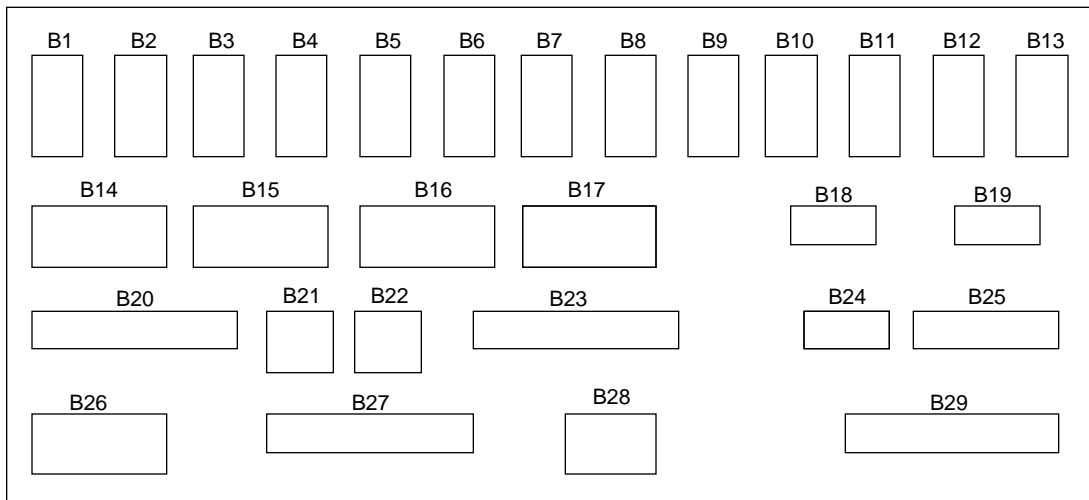

Figure 2. VME Bulkhead (Back View)

Connect ATM-1V Controller Cables

1. Locate the 20-in. fiberoptic cable assembly (P/N 90446400) and connect the 90-degree bend ends to the ATM-1V controller ports.
 - a. Attach the cable end labeled TX to the transmit port (T) on the ATM-1V controller.
 - b. Attach the other end of the cable to the VME bulkhead plate transmit (upper) connector installed in the previous subsection.

- c. Attach the cable end labeled RX to the receive port (R) on the ATM-1V controller.
- d. Attach the other end of the cable to the VME bulkhead plate receive (lower) connector installed in the previous subsection.

Install I/O Bulkhead Plate and Connectors

NOTE: The bulkhead plate assembly may be shipped preassembled. Install the SC-ST adapter (P/N 90447000) into the ATM connector bulkhead plate assembly (P/N 90447100). Secure the assembly with the two panhead screws provided (P/N 90047005).

- 1. Remove the cover plates from I/O bulkhead location A14 or A12. Refer to [Figure 3](#). Each cover plate is connected by two screws.

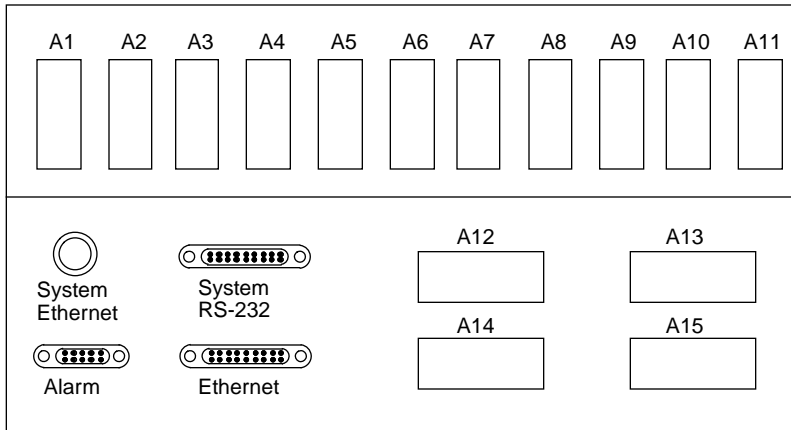

Figure 3. I/O Bulkhead

- 2. Install the assembled ATM bulkhead plate into slot A14 or A12 with the keys facing upwards. Refer to [Figure 4](#).

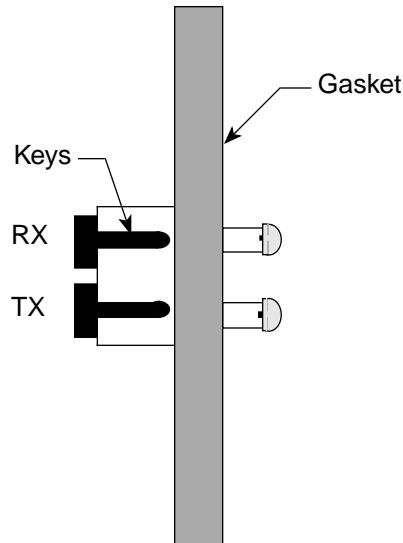

Figure 4. ATM-1V Bulkhead Connector Assembly

Connect Intermediate Cable to VME Bulkhead

1. Ensure that the multimode 3-meter cable assembly (P/N 90369300) is labeled with RX and TX on both cable ends.
2. Connect one of the ends (2 connectors, RX or TX) of the multimode 3-meter cable assemblies (P/N 90369300) to the VME bulkhead plate assembly to match the RX and TX controller cables inside the VME cabinet.

Disconnect all Cables from VME Bulkhead

NOTE: You may want to push the VME tray in and secure it with a single screw to disconnect the cables.

1. Disconnect all cables from the VME bulkhead that are routed through the flexible cable way.

NOTE: Whether one or both of the flexible cable ways are disconnected depends on the number of cables being routed and where the cables will be attached on the VME bulkhead.

2. Disconnect the flexible cable way by removing the two screws that secure it to the VME tray. Refer to [Figure 5](#).
3. Lay the cable way flat.

4. Loosen the two 1/4-turn screws from the front of the I/O cabinet just below the VME tray.
5. Remove the cable tray cover by sliding the cover out through the front of the I/O cabinet and set it aside.

NOTE: If the ATM-1V cables will be routed through only one of the two flexible cable ways, only the crossbars for that flexible cable way need to be opened. If cables will be routed through both of the flexible cable ways, both crossbars will have to be opened.

6. Pry open each crossbar of the cable way, using a standard 1/8-in. flat-bladed screwdriver and leave the inner side attached. Refer to [Figure 6](#).

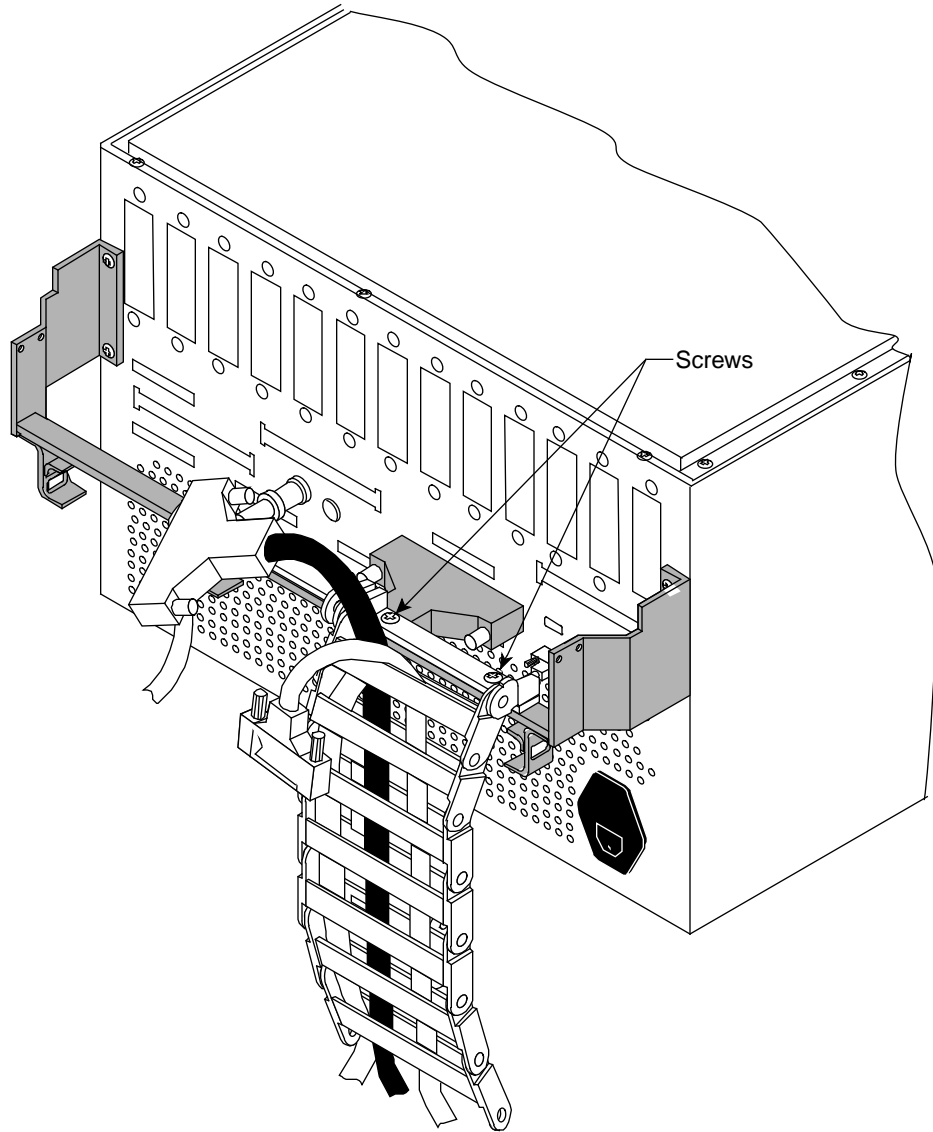

Figure 5. Flexible Cable Way

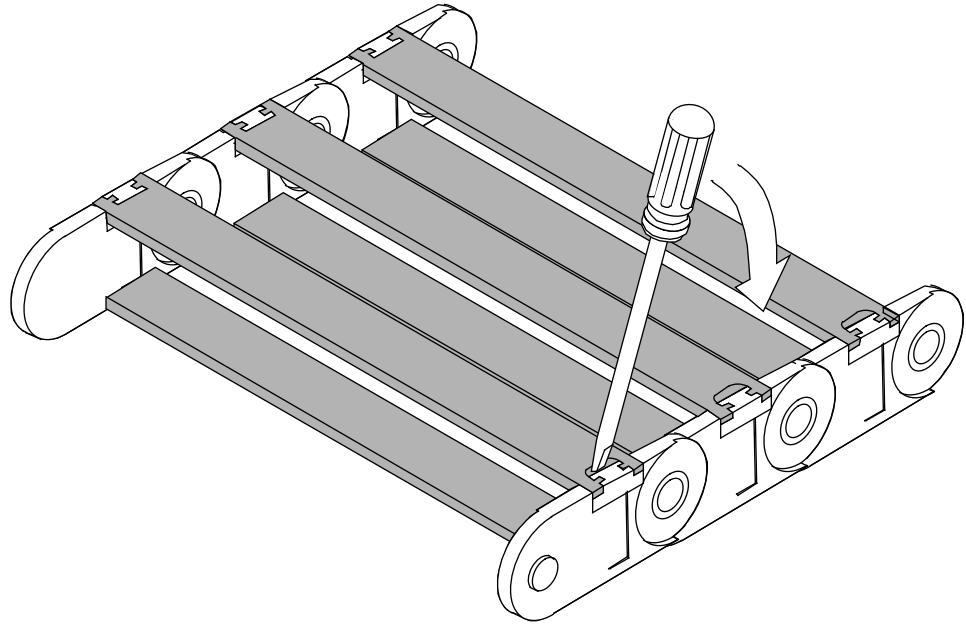

Figure 6. Flexible Cable Way Crossbars

Route Cables through Cable Tray and Flexible Cable Way

1. Place the ATM-1V cables in the flexible cable way and in the cable-routing tray. Ensure that the cables do not cross in the flexible cable way because this will make adjusting the cables more difficult.
2. After the cables have been routed, loosely secure the ATM-1V cables with tie wraps.
3. Snap down all crossbars for the flexible cable way. (This is not easy!) Then, ensure that both ends of each crossbar are secure.
4. Slide the VME tray into the cabinet carefully and secure it with one screw.

CAUTION

Do not pinch the cables when sliding in the VME tray or the cable cover.

NOTE: Y1, power, and control cables are routed below the VME flexible cable-way attachment bar.

5. Reconnect the flexible cable way using the two screws originally removed from the flexible cable-way bar. Refer to [Figure 4](#).
6. Reattach the Y1 cables to the back of the bulkhead.
7. Reattach the rest of the cables to the VME bulkhead using cable and bulkhead labels.

Connect the Multimode 3-meter Cables to the I/O Bulkhead

Connect the multimode 3-meter cable assembly (P/N 90369300) cable to the I/O bulkhead plate as shown in [Figure 3](#). Ensure that the keys are facing upwards as shown in [Figure 4](#), and then connect the cable connectors labeled RX and TX.

Replace VME Tray

1. Remove the single retaining screw and extend the VME tray out until the tray slides lock.
2. Adjust the cables slightly inside the cable tray and flexible cable way if there is excess slack at the VME bulkhead.
3. Tighten all tie wraps.
4. Reinstall the cable tray cover by sliding it carefully in and over the cable tray from the front of the I/O cabinet.
5. Secure the cable tray cover at the front of the I/O cabinet with two 1/4-turn screws.
6. Install the VME cover.
7. Slide the VME tray in carefully.
8. Install the four screws in the front of the VME tray.

Close the CRAY J90 Series I/O Cabinet Front Door

Swing the door shut and ensure that it latches.

Close the CRAY J90 Series I/O Cabinet Rear Door

1. Swing the door shut.
2. Turn the fasteners clockwise with a 5/32-in. allen wrench until the two circle symbols meet and the fastener latches.

Power Up the CRAY J90 Series System

1. Using the right mouse button, click on any open working space. The `Workspace` menu will appear.
2. Select the `J90 Console` menu item.
3. Move the circuit breaker on the back of the I/O cabinet to the ON position first, and then move the circuit breaker on the mainframe cabinet to the ON position.
4. Press the `Alarm Acknowledge` button on the CCU.
5. Press the `CPU RESET` button on the CCU.
6. Press the `VME RESET` button on the CCU.
7. Verify that the `SYSTEM READY` light on the control panel illuminates.
8. Close the mainframe front door.

Loading the IOS and Booting the System

To boot the system, perform the following steps from the system console:

1. To load the IOS, enter the following command at the IOS prompt:

```
# load
```

If the ATM-1V module is recognized in the IOS, you should see the following message displayed:

```
ATM: Unit 0 - detected
```

If there are two ATM-1V modules in an IOS, you should see the

following message also:

```
ATM: Unit 1 - detected
```

If you do not see these messages, you might see the following message:

```
drv_exec: /DEV/ATMV initialization failed
```

If you see this message, perform the following steps:

- a. Power down the IOS.
 - b. Remove the ATM-1V modules.
 - c. Recheck the jumper settings.
 - d. Reinstall the ATM-1V modules.
 - e. Perform the IOS load again.
2. Boot the system to single-user mode by entering the following command:

```
# boot
```

3. Enter multiuser mode in the UNICOS system by entering the following command:

```
# /etc/init 2
```

Testing the ATM-1V Upgrade

1. Connect the loopback connector, P/N 90452200, at the I/O bulkhead.
2. Log in as `root`.
3. Configure down the VME controllers by using the following command:

```
# /etc/ifconfig atm0 down
```

Repeat this command for each VME interface.

4. Configure up each VME controller with hardware loopback turned on for the interface by issuing the following `ifconfig` command:

```
# /etc/ifconfig atm0 edge_atm0 netmask 0xffffffff00 hwloop
```

Repeat this command for each VME interface. Change the ATM IP address and network mask values to the site's chosen values.

5. Issue the following command to configure an ATM ARP table entry:

```
# /etc/atmarp -s edge_atm0 atm0 5 0 50
```

Substitute your system's ATM IP address in this command.

6. With the cable connected in loopback configuration (from the transmit connector to the receive connector), use the `ping` command to test the ATM, as shown in the following example:

```
# /etc/ping edge_atm0
```

Execute the following command to see the input and output packets (Ipkts and Opkts fields, respectively) for each of the VME interfaces:

```
# netstat -i
```

The following example shows the output from a `netstat -i` command:

netstat -i							
Name	Mtu	Network	Address	Ipkts	Ierrs	Opkts	Oerrs
en0	1496	128.162.101	edge	253535	0	61027	0
fddi0	4352	128.162.84	edge-fddi	204070	0	24363	0
atm0	9180	128.162.83	edge_atm0	56	0	56	0
hi0*	65536	none	none	0	0	0	0
lo0	65535	127	localhost	200366	0	200366	0

7. Remove one end of the cable to verify that the ping processes stop. This verifies that the packets are going out of the transmit port of the ATM card and being received through the receive port. If the ping process continues to run, verify that each step in this section was performed.
8. Make the ATM network connection.
9. At this point, you can perform other tests across the loopback connection. Some TCP tests that can be executed are `nettest(8)`, `ftp(1B)`, and `telnet(1B)`. Refer to the appropriate man pages for details.
10. After performing these tests, disable the hardware loopback on each VME interface by executing the following command:

```
# /etc/ifconfig atm0 down
```

Repeat this command for each VME interface.

Configure Up TCP/IP for the VME Interfaces

To configure TCP/IP for the VME controllers, issue the `initif` command, as follows:

```
# /etc/initif atm0
```

The `initif(8)` command configures up the interface by performing an `ifconfig up` command and creates `atmarp` entries for each Permanent Virtual Circuit (PVC). Repeat this command for each VME interface.

Debugging a VME Problem

You can use the following commands as tools to debug a VME problem:

- `ifconfig(8)`
- `netstat(1B)`
- `atmarp(8)`
- `atmadmin(8)`

Removed Parts Disposition

Do not dispose of removed parts locally; return the removed parts to:

Cray Research, Inc.
1000 Halbleib Road
Chippewa Falls, WI 54729
Attention: Removed Equipment Management

Cruise Reporting

Report upgrades in CRUISE. Refer to *CS Reporting and Tracking Guidelines*, publication HOM-203-0, and *CRUISE User Guide*, publication HOM-248-0, for requirements and instructions.

CRAY J90™ Series ATM-1V Upgrade Procedure

HMU-163-0

Cray Research Proprietary

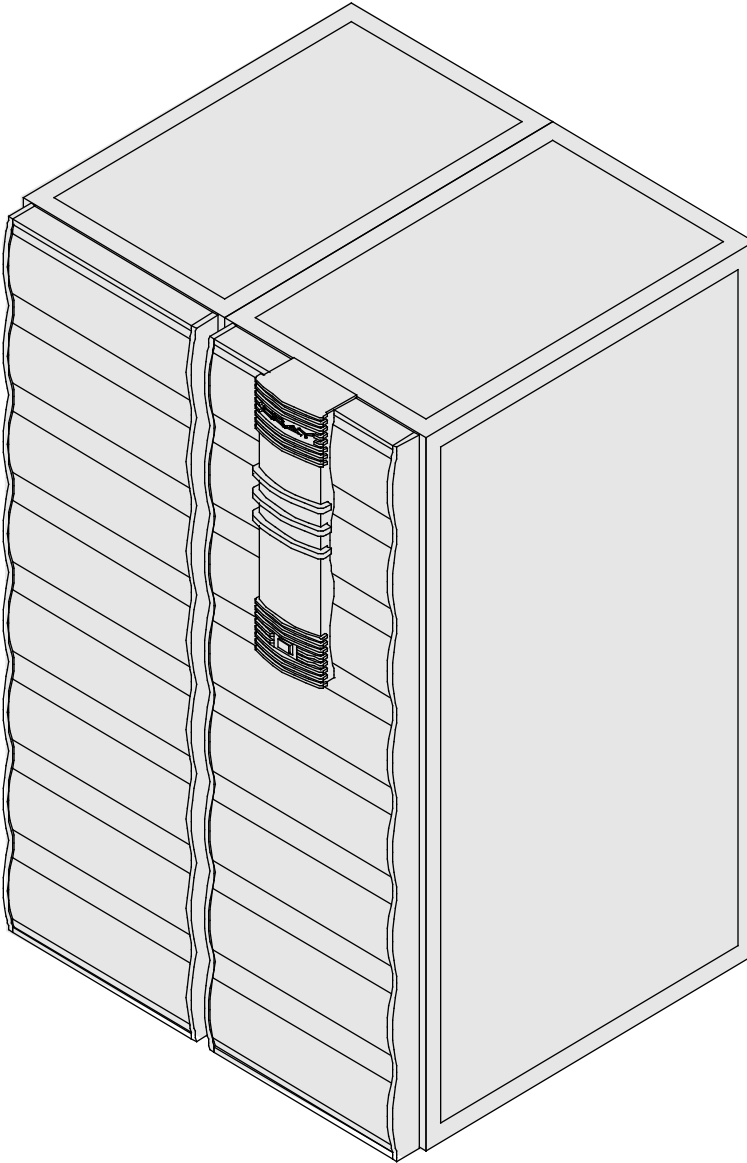

Cray Research, Inc.

Record of Revision

REVISION	DESCRIPTION
----------	-------------

April 1996. Original version that includes the Interphase ATM card.

Any shipment to a country outside of the United States requires a letter of assurance from Cray Research, Inc.

This document is the property of Cray Research, Inc. The use of this document is subject to specific license rights extended by Cray Research, Inc. to the owner or lessee of a Cray Research, Inc. computer system or other licensed party according to the terms and conditions of the license and for no other purpose.

Cray Research, Inc. Unpublished Proprietary Information — All Rights Reserved.

Autotasking, CF77, CRAY, CRAY-1, Cray Ada, CraySoft, CRAY Y-MP, HSX, LibSci, MPP Apprentice, SSD, SUPERCLUSTER, SUPERSERVER, UniChem, UNICOS, and X-MP EA are federally registered trademarks and Because no workstation is an island, CCI, CCMT, CF90, CFT, CFT2, CFT77, ConCurrent Maintenance Tools, COS, CRAY-2, Cray Animation Theater, CRAY APP, CRAY C90, CRAY C90D, Cray C++ Compiling System, CrayDoc, CRAY EL, CRAY J90, Cray NQS, Cray/REELlibrarian, CRAY S-MP, CRAY SUPERSERVER 6400, CRAY T3D, CRAY T3E, CRAY T90, CrayTutor, CRAY X-MP, CRAY XMS, CRInform, CRI/TurboKiva, CS6400, CSIM, CVT, Delivering the power . . ., DGauss, Docview, EMDS, GigaRing, HEXAR, IOS, ND Series Network Disk Array, Network Queuing Environment, Network Queuing Tools, OLNET, RQS, SEGLDR, SMARTE, SUPERLINK, System Maintenance and Remote Testing Environment, Trusted UNICOS, UNICOS MAX, and UNICOS/mk are trademarks of Cray Research, Inc.

Requests for copies of Cray Research, Inc publications should be directed to:

CRAY RESEARCH, INC.
Logistics
1100 Lowater Road
Chippewa Falls, WI 54729

Comments about this publication should be directed to:

CRAY RESEARCH, INC.
Service Publications and Training
890 Industrial Blvd.
Chippewa Falls, WI 54729

CRAY J90 SERIES ATM-1V UPGRADE PROCEDURE

Device to Be Upgraded	3
Description of Upgrade	3
ATM-1V Upgrade Prerequisites	3
Training Requirements	3
ESD Precautions	3
ESD Smock	4
Wrist Strap	4
Reference Publications	4
Estimated Time to Install Upgrade	5
Parts Required	5
Tools Required	5
Software Required	5
Conventions	6
Getting Started	6
Create a Backup Copy of the UNICOS File System	6
Modify the IOS Configuration File	6
Configure the VME Interface	7
Files Changed by ICMS	18
/etc/config/param File	19
/etc/config/atm.pvc File	21
/etc/hosts File	22
/etc/networks File	22
/etc/config/interfaces File	23
Installing the VME Hardware	24
Power Down the CRAY J90 Series System	25
Open the CRAY J90 Series I/O Cabinet Rear Door	26
Open the CRAY J90 Series I/O Cabinet Front Door	26
Install the ATM-1V Controller	26

Install VME Bulkhead Plate	28
Connect ATM-1V Controller Cables	28
Install I/O Bulkhead Plate and Connectors	29
Connect Intermediate Cable to VME Bulkhead	30
Disconnect all Cables from VME Bulkhead	30
Route Cables through Cable Tray and Flexible Cable Way	33
Connect the Multimode 3-meter Cables to the I/O Bulkhead	34
Replace VME Tray	34
Close the CRAY J90 Series I/O Cabinet Front Door	34
Close the CRAY J90 Series I/O Rear Cabinet Door	35
Power Up the CRAY J90 Series System	35
Loading the IOS and Booting the System	35
Testing the ATM-1V Upgrade	36
Configure Up TCP/IP for the VME Interfaces	38
Debugging a VME Problem	38
Removed Parts Disposition	38
Cruise Reporting	38

Figures

Figure 1. ATM-1V Jumper Settings	27
Figure 2. VME Bulkhead (Back View)	28
Figure 3. I/O Bulkhead	29
Figure 4. ATM-1V Bulkhead Connector Assembly	30
Figure 5. Flexible Cable Way	32
Figure 6. Flexible Cable Way Crossbars	33

Tables

Table 1. Estimated Times to Install Upgrade	5
Table 2. ATM-1V Upgrade Kit Contents (P/N 90446600) .	5

Device to Be Upgraded

This document contains procedures on how to add an Interphase ATM-1V asynchronous transfer mode (ATM) controller to a CRAY J90 series system.

Description of Upgrade

Cray Research customers have the option of implementing ATM in their CRAY J90 series systems. This procedure is written to aid CRI support personnel in the task of installing, configuring, and testing an ATM-1V.

This procedure includes only information for installing an Interphase ATM controller.

ATM-1V Upgrade Prerequisites

The following list describes some special configuration considerations:

- It is recommended that a full backup of existing file systems be completed before this upgrade is started
- UNICOS 8.0.4.2 release or above. The ATM driver is not supported on any earlier releases.

Training Requirements

Cray Research personnel who perform this upgrade must have completed training in CRAY J90 series hardware and system administration. If this is not possible, a hardware-trained person must have a system administrator available during this upgrade. Experience in upgrading or installing the UNICOS operating system on a CRAY J90 series system or CRAY Y-MP EL system is advised.

ESD Precautions

Observe ESD precautions during the entire upgrade process. Required apparel includes an ESD smock and an ESD wrist strap. Do not wear watches or jewelry when you work on a CRAY J90 series system cabinet.

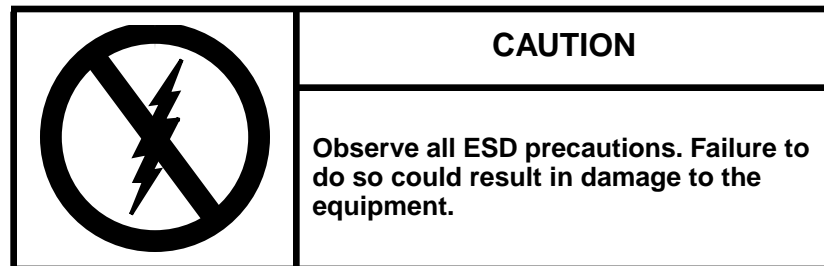

ESD Smock

Wear a Cray Research-approved static-dissipative smock when servicing or handling an ESD-sensitive device. Completely button the smock and wear it as the outermost layer of clothing. You must have a portion of the smock's sleeves in direct contact with the skin of your arms. Skin contact is essential for a dissipative path-to-earth ground through your wrist strap. Tuck hair that exceeds shoulder length inside the back of the smock.

Wrist Strap

Wear a Cray Research-approved wrist strap when handling an ESD-sensitive device to eliminate possible ESD damage to equipment. Connect the wrist strap cord directly to earth ground.

Reference Publications

- *UNICOS Basic Administration Guide for CRAY J90 and CRAY EL Series*, Cray Research publication number SG-2416
- *CRAY IOS-V Commands Reference Manual*, Cray Research publication number SR-2170
- *CRAY IOS-V Messages*, Cray Research publication number SQ-2172
- *CRAY J916 Service Manual Kit*, Cray Research publication number HMK-101-0
- *UNICOS Installation and Configuration Tool Reference Manual*, publication number SR-3090
- *UNICOS Installation/Configuration Menu System User's Guide*, publication SG-2412

Estimated Time to Install Upgrade

Table 1 divides the ATM-1V upgrade process into three separate procedures. Use this table to determine how much system time you should request to complete this upgrade.

NOTE: It is recommended that you contact the customer and request that he or she complete a full backup prior to this upgrade.

Table 1. Estimated Times to Install Upgrade

Installation Task	Estimated Time to Install Upgrade
Software Configuration and Verification	1.5 hours
Hardware Installation	1 hour
Hardware Verification Testing	0.5 hour

Parts Required

Table 2. ATM-1V Upgrade Kit Contents (P/N 90446600)

CRI Part number	Quantity	Description
90446700	1	Module Assembly, ATM-1V
90446400	1	Cable Assembly, AT-1, 20-in. Fiber Optics
90446900	1	Plate Assembly, Bulkhead ATM, BNC
90369300	1	Cable Assembly, Multimode, FDDI 3 Meters
90447000	1	Adapter, Bulkhead, SC-ST
90447100	1	Plate Assembly, Bulkhead. ATM Connector
90047005	2	Screw, Panhead Phillips 2-56X3/16SS
90452200	1	Connector, Loopback, SC Low Loss
90030500	10	Cable Tie, Mounting Nylon 4 inches

Tools Required

The majority of tools required for performing upgrades are common hand-held tools that are included with the Customer Service toolkit.

Software Required

- Minimum IOS kernel revision - 1.7
- Minimum UNICOS revision - 8.0.4.2
- No special considerations

Conventions

The following conventions are used throughout this document:

<u>Convention</u>	<u>Meaning</u>
command	This fixed-space font denotes literal items such as commands, files, routines, path names, signals, messages, and programming language structures.
manpage(<i>x</i>)	Man page section identifiers appear in parentheses after man page names.
<i>variable</i>	Italic typeface denotes variable entries, words or concepts being defined.
user input	This bold fixed-space font denotes literal items that the user enters in interactive sessions. Output is shown in nonbold, fixed-space font.
<KEY>	This convention indicates a key on the keyboard.

Getting Started

Check off each step as you complete it.

Create a Backup Copy of the UNICOS File System

It is recommended that you create a backup copy of the UNICOS file system before you proceed with the upgrade procedures. Refer to the *UNICOS Basic Administration Guide for CRAY J90 and CRAY EL Series*, publication number SG-2416, for details on how to create a backup copy of the UNICOS file system.

Modify the IOS Configuration File

In any window on the workstation, edit the IOS configuration file and add the IOS ATM driver to the appropriate IOS files, as follows:

```
# vi /opt/ios/9xxx/config
```

The following code shows an example of the added IOS ATM driver to the IOS system named IOS1 in the configuration file:

```
IOS1: 2093 1228800
#-----
#Device driver name
#-----
/dev/disk
/dev/ipi
/dev/esdi
/dev/atmi
```

Configure the VME Interface

This subsection describes the steps needed to configure the VME interface by using the UNICOS Installation / Configuration Menu System (ICMS). For information on how to use the ICMS, refer to the *UNICOS Installation/Configuration Menu System User's Guide*, publication SG-2412, and the *UNICOS Installation and Configuration Tool Reference Manual*, publication SR-3090.

When you configure the VME interface in the UNICOS operating system, you will be updating the following files:

- /etc/config/param
- /etc/config/atm.pvc
- /etc/hosts
- /etc/networks
- /etc/config/interfaces

Details on the changes made to these files are provided in the “Files Changed by ICMS” subsection, [page 18](#).

NOTE: Because some of the menus are associated with other configuration files, files other than ones previously listed will be updated. If the UNICOS Installation/Configuration Menu System resembles your system's configuration, everything will be updated appropriately. If your system's configuration does not match the UNICOS Installation/Configuration Menu System, perform [Step 3](#) through [Step 8](#) starting on [page 8](#).

To configure the VME interface by using the ICMS, perform the following steps:

1. Log in as `root`.
2. Enter the UNICOS Installation/Configuration Menu System by entering the following command on the system console:

```
# /etc/install/install
```

3. Once you are in the ICMS, it is recommended that you use the `import` utility to update the system configuration before you configure anything. To import the current system configuration into the menu system, go to the Import Options option, as shown:

```
UNICOS Installation/Configuration Menu System
. Utilities
. . Import Utility
. . . Import Options
```

4. Set the import options to the following values

```
Import Options
S-> Import root mount point
Stop import on error? YES
Import host or guest versions? host
Reload default import table ...
```

5. After selecting the Import Options, select `e`.

NOTE: It is important to import files used by the site ([Step 6](#)) to ensure that any changes initiated outside of the tool get included before changes made for ATM are activated.

6. Exit the Import Options option and select the Import Table option, as shown:

```
UNICOS Installation/Configuration Menu System
. Utilities
. . Import Utility
. . . Import Table
```

The configuration files associated with ATM must be imported. Set to `NO` any Import Table option that your site does not use. Set the following Import Table options to `YES`:

Import Table					
Class	Description	Import?	Program	Options	
E->	HARDWARE	Param	YES	hdwparam.sh	-i \$RELEA
	KERNEL	Config.h uts	YES	utsconfh.sh	-i \$RELEA
	KERNEL	Param uts	YES	utsparam.sh	-i \$RELEA
	KERNEL	Comm channels	YES	utscparam.sh	-i \$RELEA
	HOSTS	Hosts	YES	utlimp.sh	hosts
	NETWORKS	Networks	YES	utlimp.sh	networks
	NETIF	Network Interfaces	YES	netifs.sh	-i

7. Exit the Import Table option by selecting e, and select the Import Utility option, as shown:

```

UNICOS Installation/Configuration Menu System
.  Utilities
.  .  Import Utility
    
```

Set the Import class to run option to ALL, as follows:

```

Import Utility
Import options ==>
M-> Import table ==>
Import class to run
ALL
Run the import process ...
    
```

8. Execute the Run the import process option. This option overwrites the menu system database. Exit the Import Utility option and answer y (yes) to the following question:

```

Do you want to continue? y
    
```

9. Go to the Native ATM Configuration option, as shown:

```

UNICOS Installation/Configuration Menu System
.  Configure System
.  .  Kernel Configuration
.  .  .  Communication Channel Configuration
.  .  .  .  Native ATM Device Configuration
    
```

Enter the appropriate parameters to build the atmdev entries in the /etc/config/param file, as in the following example:

```

Native ATM Configuration
-> ATM device ordinal    0
    I/O cluster number   0
    IOP number           0
    IOP Channel number   020

```

The following list describes the parameters:

<u>Parameter</u>	<u>Description</u>
ATM device ordinal	Specifies the VME interface that will be defined in the param file. Possible values are 0 through 15.
I/O cluster number	Specifies the IOS in which the ATM module will reside. Possible values are 0 through 15.
IOP number	Value must be 0.
IOP channel number	Specifies the channel number that the I/O processor (IOP) uses to communicate with the ATM controller in the IOS. A maximum of two ATM controllers are allowed per IOS. Use channel 20 octal for the first ATM controller and channel 21 octal for the second.

Create entries for all VME interfaces that are being installed.

- Exit the Native ATM Configuration option and answer y (yes) to the following question:

```
Do you want to update form file? (y/n): y
```

- To configure the VME interfaces, go to the Network Parameters option, as shown:

```

UNICOS Installation/Configuration Menu System
.   Configure System
.   .   Kernel Configuration
.   .   .   Network Parameters

```

To update the `/etc/config/param` file, enter the appropriate network parameters, as shown in the following example:

Network Parameters	
Number of TCP memory buffers (TCP_NMBSPACE)	4000
Max. Native ATM network devices (atmmxdevs)	2
ATM ARP receive space (atmarp_recv)	131072
ATM ARP send space (atmarp_send)	65536
Max. ATM ARP entries (atmarp_entries)	1024

The following list describes the parameters:

<u>Parameter</u>	<u>Description</u>
Number of TCP memory buffers (TCP_NMBSPACE)	Specifies the number of mbufs to be defined for the system. This value is system-dependent.
Max. Native ATM network devices (atmmxdevs)	Specifies the maximum number of ATM modules allowed for this system. Valid values are 1 through 16. Set this value to the number of ATM interfaces to be installed in this system.
ATM ARP receive space (atmarp_recv)	Specifies the amount of socket receive space used by the atmarp(1) command. This value should always be a power of 2. The default value of 131072 should be sufficient for most systems.
ATM ARP send space (atmarp_send)	Specifies the amount of socket send space used by the atmarp(1) command. This value should always be a power of 2. The default value of 65536 should be sufficient for most systems.
Max. ATM ARP entries (atmarp_entries)	Specifies the maximum number of address resolution protocol (ARP) entries allowed in the ATM ARP table. The default value of 1024 should be sufficient for most systems. This value is directly related to the number of remote hosts that communicate through the ATM.

12. To activate the kernel configuration, go to the Activate the Kernel Configuration option, as shown:

```

UNICOS Installation/Configuration Menu System
.   Configure System
.   .   Kernel Configuration
.   .   .   Activate the Kernel Configuration

```

Answer y (yes) to the following question:

Do you want to proceed with the configuration update? **y**

You need to complete the next two steps only if you will be configuring Permanent Virtual Circuits (PVCs) for remote hosts with which this system will communicate through the VME interface. PVCs provide a means to state a path to a remote host specifically. PVCs are created and deleted by using the `atmarp(8)` command. The next two steps configure the parameters that will be used by the `atmarp(8)` command.

NOTE: Switched Virtual Circuit (SVC) support is under development and will be added to the UNICOS system at a later release. SVCs are a dynamic way to create a path to a remote host. SVCs use a protocol called *signaling* to set up and delete an available path between two hosts. The software performs SVCs automatically.

13. Exit the Activate the Kernel Configuration option by entering e, and go to the Permanent Virtual Circuit Configuration option, as shown:

```

UNICOS Installation/Configuration Menu System
.   Configure System
.   .   Network Configuration
.   .   .   Native ATM Configuration
.   .   .   .   Permanent Virtual Circuit Configuration

```

To update the `/etc/config/atm.pvc` file, use the n key to enter the Permanent Virtual Circuits (PVCs) for all remote hosts with which this system will communicate through the VME interface. The following text is an example of a `/etc/config/atm.pvc` file:

Permanent Virtual Circuit Configuration						
	Remote Hostname	Interface	AAL	VPI	VCI	QOS (Kb/s)
	-----	-----	---	---	---	-----
E->	remotehost_atm0	atm0	5	0	32	1
	remotehost_atm1	atm1	5	0	33	1

Following is a description of the parameters:

<u>Parameter</u>	<u>Description</u>
Remote Hostname	Specifies the IP host name of the remote host. This name must be located in the <code>/etc/hosts</code> file.
Interface	Specifies the name of the VME interface that this system will use to reach the remote host. The name is as it appears in the output of the <code>netstat -i</code> command.
AAL	Specifies the ATM Adaptation Layer (AAL) to be used by this PVC. This value is based on ATM standards. Currently, the ATM connection supports only AAL 5. Specify this number in decimal form.
VPI	Specifies the Virtual Path Identifier (VPI). The VPI is placed into each ATM cell header so that the cell can be routed through the ATM network. Currently, ATM interfaces support only VPI 0. Specify this number in decimal form.
VCI	Specifies the Virtual Channel Identifier (VCI). The VCI is placed into each ATM cell header so that the cell can be routed through the ATM network. This number should be between 32 and 1023. Consult your local network administrator when determining the VCI. Specify this number in decimal form.
QOS (Kb/s)	Specifies the quality of service expressed in kilobits per second. This is the peak data rate at which this host will deliver ATM cells to the remote host through the ATM interface. Placing a 0 in this field causes the peak rate control feature to be disabled when sending to this remote host, thus allowing unlimited bandwidth. Specify this number in decimal form.

14. Exit the Permanent Virtual Circuit Configuration option by entering e, and answer y (yes) to the following question:

Do you want to update form file? (y/n): **y**

15. To activate the VME (Native ATM) configuration, go to the Activate the Native ATM Configuration option, as shown:

```
UNICOS Installation/Configuration Menu System
.   Configure System
.   .   Network Configuration
.   .   .   Native ATM Configuration
.   .   .   .   Activate the Native ATM Configuration
```

Answer y (yes) to the following question:

Do you want to proceed with the configuration update? **y**

16. Exit the Activate the Native ATM Configuration option by entering e, and go to the Host Address Configuration option, as shown:

```
UNICOS Installation/Configuration Menu System
.   Configure System
.   .   Network Configuration
.   .   .   General Network Configuration
.   .   .   .   Host Address Configuration
```

To update the /etc/hosts file, use the n key to configure the VME connection for TCP/IP. The following screen is an example of a /etc/hosts file:

Host Address Configuration			
Proto	Name	Address	Comment
-----	----	-----	-----
inet	edge_atm0	128.162.102.25	
inet	remotehost_atm0	128.162.102.30	
inet	remotehost_atm1	128.162.102.31	

The following list describes the configuration parameters:

<u>Parameter</u>	<u>Description</u>
Proto	Specifies the Internet protocol
Name	Specifies the IP address alias
Address	Specifies the standard IP address value

17. To update the /etc/networks file, go to the Network Address Configuration option, as shown:

```

UNICOS Installation/Configuration Menu System
.   Configure System
.   .   Network Configuration
.   .   .   General Network Configuration
.   .   .   .   Network Address Configuration
    
```

Configure the ATM Internet network address for TCP/IP by creating an entry in the /etc/networks file for each ATM network. There will be a network address for each ATM interface that will communicate through TCP/IP. The following screen is an example of a /etc/networks file:

Network Address Configuration				
	Proto	Name	Address	Comment
	-----	----	-----	-----
E->	inet	atmnet	128.162.102	

The following list describes the configuration parameters:

<u>Parameter</u>	<u>Description</u>
Proto	Specifies the Internet protocol
Name	Specifies the IP address alias
Address	Specifies the standard IP address value

18. Exit the Network Address Configuration option by entering e, and go to the Network Interface Configuration option, as follows:

```

UNICOS Installation/Configuration Menu System
.   Configure System
.   .   Network Configuration
.   .   .   General Network Configuration
.   .   .   .   Network Interface Configuration
    
```

To update the /etc/config/interfaces file, use the n key to enter the appropriate information to automatically configure up the VME interface during a UNICOS boot for this system, as shown in the following example:

Network Interface Configuration							
Name	Hycf	Family	Address	Dest	Subnet	Type	Bcst
----	----	----	----	----	----	----	----
lo0		inet	localhost				
en0		inet	edge.cray.com		0xffffffff00		
fddi0		inet	edge-fddi.cray.com		0xffffffff00		128.16
E-> atm0		inet	edge-atm0		0xffffffff00	pvc	

The following list describes the configuration parameters:

<u>Parameter</u>	<u>Description</u>
Name	Specifies the interface name and ordinal of the ATM interface to be configured. The syntax is atm x , where x is the ordinal number of the ATM interface.
Hycf	Not used.
Family	Must be set to inet.
Address	Specifies the IP host address for this interface connection. This parameter must be defined in the <code>/etc/hosts</code> file.
Dest	Specifies the destination (point-to-point) address. It is not needed for the ATM connection.
Subnet	Specifies the subnetwork address mask to be used for this interface.
Type	Specifies the interface type, used to select the type of signaling to be used across the ATM network. These values also imply the type of encapsulation used for IP datagrams. The following types are supported: <ul style="list-style-type: none"> • <code>pvc</code> - Permanent Virtual Circuit. Implies 802.2 LLC encapsulation. • <code>spans</code> - Simple Protocol for ATM Network Signaling (SPANS) protocol. Implies null encapsulation and Switched Virtual Circuits (SVC).

<u>Parameter</u>	<u>Description</u>
	<ul style="list-style-type: none"> q2931 - Q2931 is the Switched Virtual Circuit standard. This is under development and does not currently work. Implies 802.2 LLC encapsulation and Switched Virtual Circuits (SVC). <p>NOTE: If the interface type is set to pvc, signaling will not be performed on that interface. However, if an interface is marked as spans or q2931, PVCs are still supported on that interface when you use the atmarp command to place them in the atmarp table.</p>
Bcst	Specifies broadcast address.

19. Exit the Network Interface Configuration option by entering e, and answer y (yes) to the following question:

```
Do you want to update form file? (y/n): y
```

20. Go to the General Network Configuration option, as follows:

```
UNICOS Installation/Configuration Menu System
.   Configure System
.   .   Network Configuration
.   .   .   General Network Configuration
```

21. Activate general network configuration, as follows:

```
General Network Configuration
Host address configuration ==>
Network address configuration ==>
Networking services configuration ==>
Network hardware address configuration ==>
Network interface configuration ==>
Import general network configuration ==>
A-> Activate general network configuration
```

Answer y (yes) to the following question:

```
Do you want to proceed with the configuration update? y
```

22. Copy the param file to the console disk by selecting the Expander File Transfers menu, as follows:

```

UNICOS Installation/Configuration Menu System
.   Utilities
.   .   File Transfer Utilities

```

23. Verify that the following parameters are configured to transfer the /etc/config/param file to the console disk:

```

Expander File Transfers

```

```

S->Transfer UNICOS kernel to the expander? NO
Transfer CSL param file to the expander? YES

```

```

Expander directory name           sys
Expander file name suffix

```

```

Do the transfer to the expander . . .

```

24. Execute the transfer by selecting the following option:

```

A-> Do the transfer to the expander ...

```

25. Exit the UNICOS Installation/Configuration Menu System by typing q (quit) and answering y (yes) to the following question:

```

Do you want to quit? y

```

For examples of the files that have been updated by the preceding process, refer to the following subsections.

Files Changed by ICMS

The following subsections describe and show examples of the files that are updated when you configure the VME interface by using the ICMS. The examples in the following subsections show only the part of the files that relate to the ATM interface configuration. Exact parameter settings will be system-dependent.

The following files are updated:

- /etc/config/param
- /etc/config/atm.pvc
- /etc/hosts

- /etc/networks
- /etc/config/interfaces

/etc/config/param File

The /etc/config/param file contains the parameters needed to configure the VME interface for the host system.

In the network section of the file, you must create entries for all VME interfaces that are being installed. Enter appropriate values for the following parameters:

<u>Parameter</u>	<u>Description</u>
tcp_nmbspace	Number of TCP memory buffers. Specifies the number of mbufs to be defined for the system. This value is system-dependent.
atmmxdevs	Maximum VME (Native ATM) network devices. Specifies the maximum number of VME modules allowed for this system. Valid values are 1 through 16. Set this value to the number of VME interfaces to be installed in this system.
atmarp_recv	ATM ARP receive space. Specifies the amount of socket receive space used by the atmarp(1) command. This value should always be a power of 2. The default value of 131072 should be sufficient for most systems.
atmarp_send	ATM ARP send space. Specifies the amount of socket send space used by the atmarp(1) command. This value should always be a power of 2. The default value of 65536 should be sufficient for most systems.
atmarp_entries	Maximum ATM ARP entries. Specifies the maximum number of address resolution protocol (ARP) entries allowed in the ATM ARP table. The default value of 1024 should be sufficient for most systems. This value is directly related to the number of remote hosts that communicate through the ATM.
atmdev	ATM device ordinal. Specifies the ATM interface that will be defined in the param file. Possible values are 0 through 15.

<u>Parameter</u>	<u>Description</u>
path	I/O path that consists of the following three parameters: cluster, eiop, and channel.
cluster	I/O cluster number. Specifies the IOS in which the ATM module will reside. Possible values are 0 through 15.
eiop	IOP number. This number will always be 0.
channel	IOP channel number. Specifies the channel number that the I/O processor (IOP) uses to communicate with the ATM module in the IOS. This number is unique to each IOS. Valid values for this field are octal 20 and octal 21. Use octal 20 for the first module and octal 21 for the second module.

The following screen is an example of a `/etc/config/param` file:

```
# /etc/config/param file
.
.
.
network {
    4000 tcp_nmbospace;
    2 atmmaxdevs;
    131072 atmarp_recv;
    65536 atmarp_send;
    1024 atmarp_entries;
.
.
.
atmdev 0 {
    iopath {
        cluster 0;
        eiop 0;
        channel 020;
    }
}
.
.
.
```

/etc/config/atm.pvc File

The `/etc/config/atm.pvc` file shows the Permanent Virtual Circuits (PVCs) for all remote hosts that will communicate to this system through the ATM interfaces.

Create the following parameters in the `/etc/config/atm.pvc` file:

<u>Parameter</u>	<u>Description</u>
<code>remote.host.name</code>	IP host name of the remote host. This name must be located in the <code>/etc/hosts</code> file.
<code>interface</code>	Name of the ATM interface that this system will use to reach the remote host. The name is as it appears in the output of the <code>netstat -i</code> command.
<code>AAL.number</code>	ATM Adaptation Layer (AAL) to be used by this PVC. This value is based on ATM standards. Currently, the ATM connection supports only AAL 5. Specify this number in decimal form.
<code>VPI.number</code>	Virtual Path Identifier (VPI), placed into each ATM cell header so that the cell can be routed through the ATM network. Currently, ATM interfaces support only VPI 0. Specify this number in decimal form.
<code>VCI.number</code>	Virtual Channel Identifier (VCI), placed into each ATM cell header so that the cell can be routed through the ATM network. This number should be between 32 and 1023. Consult your local network administrator when determining the VCI. Specify this number in decimal form.
<code>QOS.number</code>	Quality of service expressed in kilobits per second. This is the peak data rate at which this host will deliver ATM cells to the remote host through the ATM interface. Placing a 0 in this field causes the peak rate control feature to be disabled when sending to this remote host, thus allowing unlimited bandwidth. Specify this number in decimal form.

The following text is an example of a `/etc/config/atm.pvc` file:

```

#/etc/config/atm.pvc file

# hostname      ifc      AAL      VPI      VCI      QOS
# -----      ---      ---      ---      ---      ---
#
remotehost_atm0 atm0      5        0        32       0
remotehost_atm1 atm1      5        0        33       0

```

/etc/hosts File

The `/etc/hosts` file contains host names. Create the following parameters in this file:

<u>Parameter</u>	<u>Description</u>
address	Standard IP address value
name	IP address alias

The following screen is an example of a `/etc/hosts` file:

```

#/etc/hosts file

128.162.102.25      edge-atm0
128.162.102.30      remotehost_atm
128.162.102.31      remotehost_atm1

```

/etc/networks File

The `/etc/networks` file contains the name and address of your ATM network. Create the following parameters in this file:

<u>Parameter</u>	<u>Description</u>
name	IP address alias
address	Standard IP address value

The following screen is an example of a `/etc/networks` file:

```

#/etc/networks file

atm01      128.162.102
.
.
.

```

Create as many entries as there are VME ATM interfaces configured for TCP/IP.

`/etc/config/interfaces` File

The `/etc/config/interfaces` file contains the parameters required to configure up the ATM interface by using the `/etc/initif` script.

Create the following parameters in the `/etc/config/interfaces` file:

<u>Parameter</u>	<u>Description</u>
name	Interface name and ordinal of the ATM interface to be configured.
family	Interface family name. Must be set to <code>inet</code> .
IP.host_address	IP host address for this interface connection. This parameter must be defined in the <code>/etc/hosts</code> file.
subnet	Subnetwork address mask to be used for this interface.
interface.type	Interface type, used to select the type of signaling to be used across the ATM network. These values also imply the type of encapsulation used for IP datagrams. The following types are supported: <ul style="list-style-type: none"> • <code>pvc</code> - Permanent Virtual Circuit. Implies 802.2 LLC encapsulation. • <code>spans</code> - Simple Protocol for ATM Network Signaling (SPANS) protocol. Implies null encapsulation and Switched Virtual Circuits (SVCs).

<u>Parameter</u>	<u>Description</u>
	<ul style="list-style-type: none"> q2931 - Q2931 is the Switched Virtual Circuit standard. This is under development and does not currently work. Implies 802.2 LLC encapsulation and Switched Virtual Circuits (SVC). <p>NOTE: If the interface type is set to pvc, signaling will not be performed on that interface. However, if an interface is marked as spans or q2931, PVCs are still supported on that interface when you use the atmarp command to place them in the atmarp table.</p>

The following text is an example of a /etc/config/interfaces file:

```

#/etc/config/interfaces file
# File format is:
#
# name   hycf_file      family  address          pt-to-pt-dest    args:
#                                     netmask
#                                     iftype
#                                     broadcast
#                                     mtu
#                                     rbuf
#                                     wbuf
#                                     bg
#                                     hwloop
atm0    -              inet    edge-atm0 -      netmask 0xffffffff00 iftype pvc

```

Installing the VME Hardware

The installation of the VME hardware consists of the following procedures:

- Powering down and removing panels
- Setting the ATM-1V jumpers

NOTE: The labels on the ATM-1V cables have the following meanings:

Transmit [TX] = output
 Receive [RX] = input

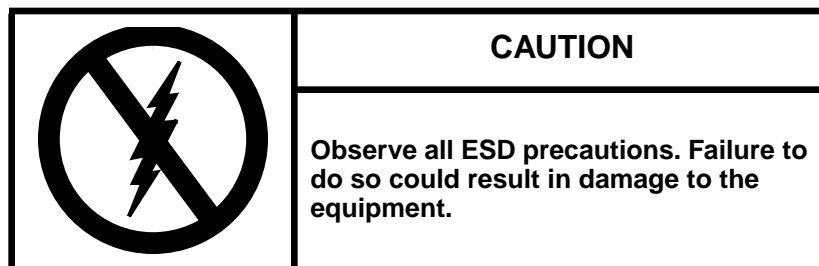

Power Down the CRAY J90 Series System

1. Ensure that the customer has brought the system to single-user mode.
2. Using the right mouse button, click on any open working space. The `Workspace` menu will appear.
3. From the `Workspace` Menu, select the `J90 Console` menu item.

NOTE: You must have superuser privileges to perform [Step 4](#).

4. Log into the UNICOS operating system by entering `<CONTROL-a>` to get a UNICOS prompt and enter the root login and password.
5. Shut down the UNICOS operating system by entering the following commands at a UNICOS prompt:

```
# cd /
# /etc/shutdown 120      (executes after 120 seconds)
# /bin/sync
# /bin/sync
# /bin/sync
# /etc/ldsync           (if you are using ldcache)
```

6. Stop the `J90 Console` connection by entering the following commands:

```
# <CONTROL-a>          (toggles to the IOS)
sn9xxx-ios0> mc
sn9xxx-ios0> reset      (takes 30 – 45 seconds to execute)
BOOT[sn9xxx-ios0]> ~. <CONTROL-c>
```

7. Open the mainframe cabinet front door by pushing down on the latch and swinging the door open.
8. Power off the system by pressing the `CCU SYSTEM OFF` button.

Open the CRAY J90 Series I/O Cabinet Rear Door

1. At the rear of the I/O cabinet, locate the two door-locking fasteners at the left top and left bottom of the door. Turn these fasteners 1/4-turn counterclockwise with a 5/32-in. allen wrench.
2. Grasp the door handle and swing the door open to the right.

Open the CRAY J90 Series I/O Cabinet Front Door

1. At the front of the I/O cabinet, locate the latch on the upper-right corner of the door.
2. Push down on the latch and swing the door open.

Install the ATM-1V Controller

Install the ATM-1V controller board into the correct IOS (depending on customer's system configuration) using the next available slot in that IOS.

1. Pull out the VME tray.
 - a. Remove the four screws that secure the VME tray to the cabinet.
 - b. Pull out the VME tray as far as it will go.
 - c. Release the screws that hold the top cover to the VME tray.
 - d. Remove the top cover from the VME tray and set it aside.
2. Unpack the new controller board if you are performing an upgrade.
3. Place the new board on an ESD-protected surface.
4. Change any jumpers or switches necessary on the new ATM-1V controller board. Refer to [Figure 1](#).
5. Select and remove the appropriate VME slot filler from the slot where the ATM-1V controller board will be installed.
6. Insert the ATM-1V controller board into the guide slots in the VME chassis.
7. Secure the ATM-1V controller board by tightening the screws to the VME chassis.

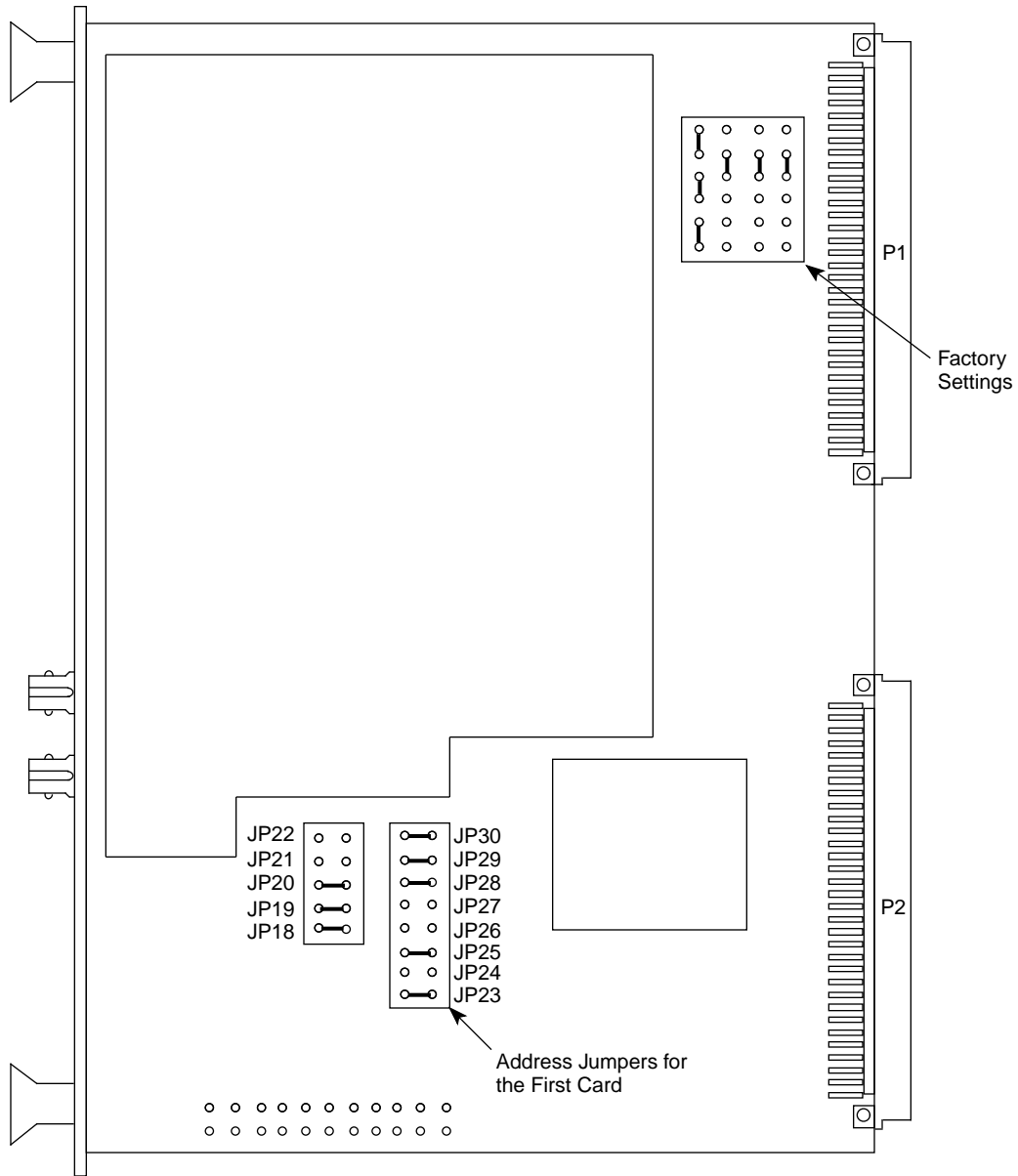

NOTE: Second and third ATM controller switch Settings in an IOS

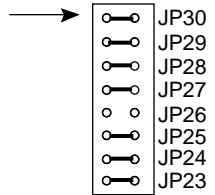
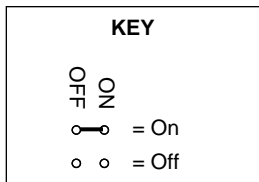

Second Card

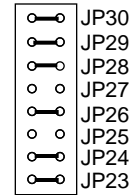

Third Card

Figure 1. ATM-1V Jumper Settings

Install VME Bulkhead Plate

Try to use a location on the bulkhead that is in line with the new ATM-1V controller in the IOS to minimize the crossing of cables.

1. Remove the appropriate blank bulkhead plate that is attached to the VME bulkhead by two screws. Refer to [Figure 2](#) for the location of the VME bulkhead.
2. Install the BNC bulkhead plate assembly (P/N 90446900); use the two screws that you removed in the previous step ([Step 1](#)). The upper connector on the plate is the transmit connector and the lower connector is the receive connection.

NOTE: Ensure that the plate's gasket is positioned away from the metal mesh of the adjacent plate.

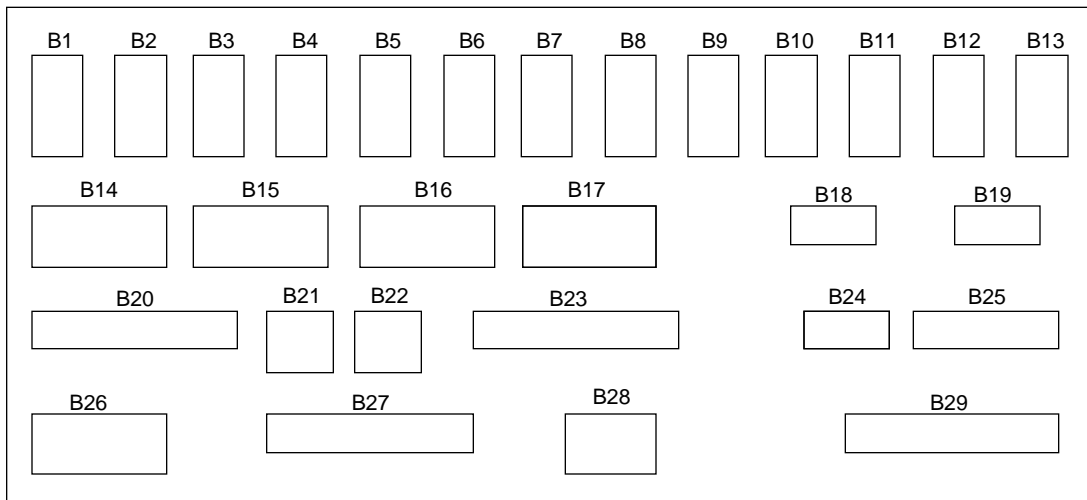

Figure 2. VME Bulkhead (Back View)

Connect ATM-1V Controller Cables

1. Locate the 20-in. fiberoptic cable assembly (P/N 90446400) and connect the 90-degree bend ends to the ATM-1V controller ports.
 - a. Attach the cable end labeled TX to the transmit port (T) on the ATM-1V controller.
 - b. Attach the other end of the cable to the VME bulkhead plate transmit (upper) connector installed in the previous subsection.

- c. Attach the cable end labeled RX to the receive port (R) on the ATM-1V controller.
- d. Attach the other end of the cable to the VME bulkhead plate receive (lower) connector installed in the previous subsection.

Install I/O Bulkhead Plate and Connectors

NOTE: The bulkhead plate assembly may be shipped preassembled. Install the SC-ST adapter (P/N 90447000) into the ATM connector bulkhead plate assembly (P/N 90447100). Secure the assembly with the two panhead screws provided (P/N 90047005).

1. Remove the cover plates from I/O bulkhead location A14 or A12. Refer to [Figure 3](#). Each cover plate is connected by two screws.

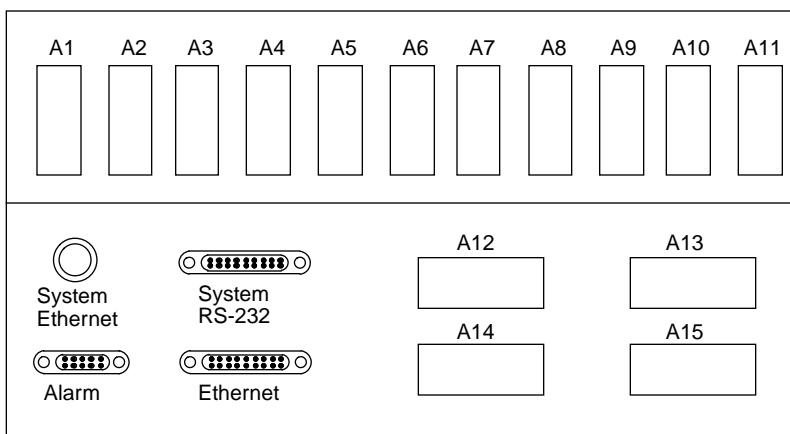

Figure 3. I/O Bulkhead

2. Install the assembled ATM bulkhead plate into slot A14 or A12 with the keys facing upwards. Refer to [Figure 4](#).

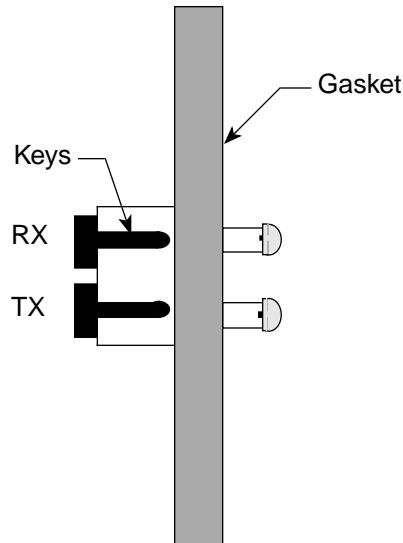

Figure 4. ATM-1V Bulkhead Connector Assembly

Connect Intermediate Cable to VME Bulkhead

1. Ensure that the multimode 3-meter cable assembly (P/N 90369300) is labeled with RX and TX on both cable ends.
2. Connect one of the ends (2 connectors, RX or TX) of the multimode 3-meter cable assemblies (P/N 90369300) to the VME bulkhead plate assembly to match the RX and TX controller cables inside the VME cabinet.

Disconnect all Cables from VME Bulkhead

NOTE: You may want to push the VME tray in and secure it with a single screw to disconnect the cables.

1. Disconnect all cables from the VME bulkhead that are routed through the flexible cable way.

NOTE: Whether one or both of the flexible cable ways are disconnected depends on the number of cables being routed and where the cables will be attached on the VME bulkhead.

2. Disconnect the flexible cable way by removing the two screws that secure it to the VME tray. Refer to [Figure 5](#).
3. Lay the cable way flat.

4. Loosen the two 1/4-turn screws from the front of the I/O cabinet just below the VME tray.
5. Remove the cable tray cover by sliding the cover out through the front of the I/O cabinet and set it aside.

NOTE: If the ATM-1V cables will be routed through only one of the two flexible cable ways, only the crossbars for that flexible cable way need to be opened. If cables will be routed through both of the flexible cable ways, both crossbars will have to be opened.

6. Pry open each crossbar of the cable way, using a standard 1/8-in. flat-bladed screwdriver and leave the inner side attached. Refer to [Figure 6](#).

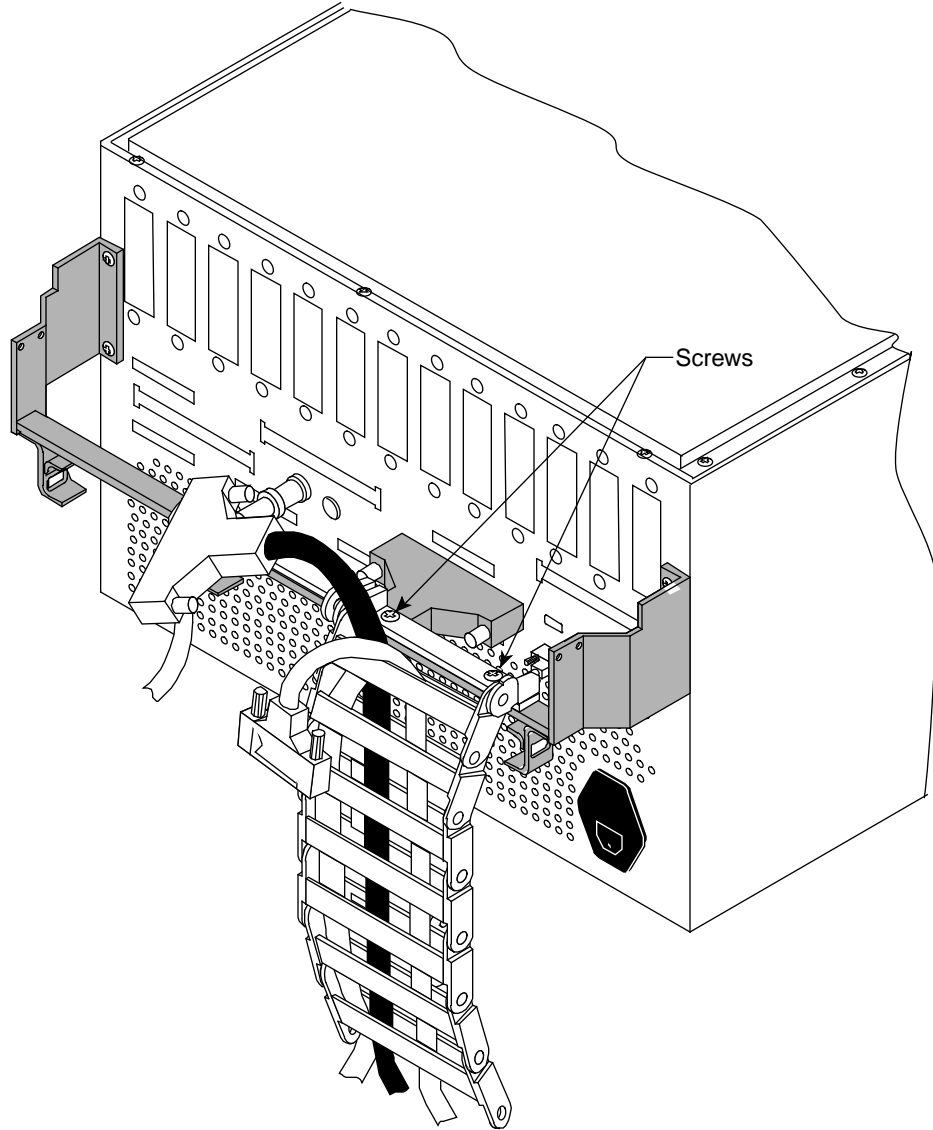

Figure 5. Flexible Cable Way

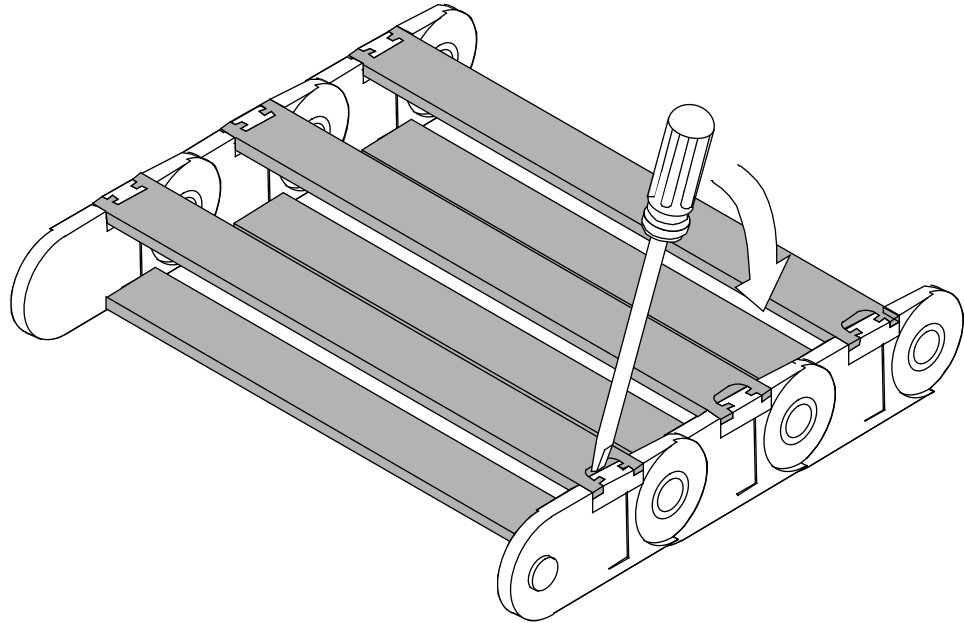

Figure 6. Flexible Cable Way Crossbars

Route Cables through Cable Tray and Flexible Cable Way

1. Place the ATM-1V cables in the flexible cable way and in the cable-routing tray. Ensure that the cables do not cross in the flexible cable way because this will make adjusting the cables more difficult.
2. After the cables have been routed, loosely secure the ATM-1V cables with tie wraps.
3. Snap down all crossbars for the flexible cable way. (This is not easy!) Then, ensure that both ends of each crossbar are secure.
4. Slide the VME tray into the cabinet carefully and secure it with one screw.

CAUTION

Do not pinch the cables when sliding in the VME tray or the cable cover.

NOTE: Y1, power, and control cables are routed below the VME flexible cable-way attachment bar.

5. Reconnect the flexible cable way using the two screws originally removed from the flexible cable-way bar. Refer to [Figure 4](#).
6. Reattach the Y1 cables to the back of the bulkhead.
7. Reattach the rest of the cables to the VME bulkhead using cable and bulkhead labels.

Connect the Multimode 3-meter Cables to the I/O Bulkhead

Connect the multimode 3-meter cable assembly (P/N 90369300) cable to the I/O bulkhead plate as shown in [Figure 3](#). Ensure that the keys are facing upwards as shown in [Figure 4](#), and then connect the cable connectors labeled RX and TX.

Replace VME Tray

1. Remove the single retaining screw and extend the VME tray out until the tray slides lock.
2. Adjust the cables slightly inside the cable tray and flexible cable way if there is excess slack at the VME bulkhead.
3. Tighten all tie wraps.
4. Reinstall the cable tray cover by sliding it carefully in and over the cable tray from the front of the I/O cabinet.
5. Secure the cable tray cover at the front of the I/O cabinet with two 1/4-turn screws.
6. Install the VME cover.
7. Slide the VME tray in carefully.
8. Install the four screws in the front of the VME tray.

Close the CRAY J90 Series I/O Cabinet Front Door

Swing the door shut and ensure that it latches.

Close the CRAY J90 Series I/O Cabinet Rear Door

1. Swing the door shut.
2. Turn the fasteners clockwise with a 5/32-in. allen wrench until the two circle symbols meet and the fastener latches.

Power Up the CRAY J90 Series System

1. Using the right mouse button, click on any open working space. The `Workspace` menu will appear.
2. Select the `J90 Console` menu item.
3. Move the circuit breaker on the back of the I/O cabinet to the `ON` position first, and then move the circuit breaker on the mainframe cabinet to the `ON` position.
4. Press the `Alarm Acknowledge` button on the CCU.
5. Press the `CPU RESET` button on the CCU.
6. Press the `VME RESET` button on the CCU.
7. Verify that the `SYSTEM READY` light on the control panel illuminates.
8. Close the mainframe front door.

Loading the IOS and Booting the System

To boot the system, perform the following steps from the system console:

1. To load the IOS, enter the following command at the IOS prompt:

```
# load
```

If the ATM-1V module is recognized in the IOS, you should see the following message displayed:

```
ATM: Unit 0 - detected
```

If there are two ATM-1V modules in an IOS, you should see the

following message also:

```
ATM: Unit 1 - detected
```

If you do not see these messages, you might see the following message:

```
drv_exec: /DEV/ATMV initialization failed
```

If you see this message, perform the following steps:

- a. Power down the IOS.
 - b. Remove the ATM-1V modules.
 - c. Recheck the jumper settings.
 - d. Reinstall the ATM-1V modules.
 - e. Perform the IOS load again.
2. Boot the system to single-user mode by entering the following command:

```
# boot
```

3. Enter multiuser mode in the UNICOS system by entering the following command:

```
# /etc/init 2
```

Testing the ATM-1V Upgrade

1. Connect the loopback connector, P/N 90452200, at the I/O bulkhead.
2. Log in as `root`.
3. Configure down the VME controllers by using the following command:

```
# /etc/ifconfig atm0 down
```

Repeat this command for each VME interface.

4. Configure up each VME controller with hardware loopback turned on for the interface by issuing the following `ifconfig` command:

```
# /etc/ifconfig atm0 edge_atm0 netmask 0xffffffff00 hwloop
```

Repeat this command for each VME interface. Change the ATM IP address and network mask values to the site's chosen values.

5. Issue the following command to configure an ATM ARP table entry:

```
# /etc/atmarp -s edge_atm0 atm0 5 0 50
```

Substitute your system's ATM IP address in this command.

- With the cable connected in loopback configuration (from the transmit connector to the receive connector), use the `ping` command to test the ATM, as shown in the following example:

```
# /etc/ping edge_atm0
```

Execute the following command to see the input and output packets (Ipkts and Opkts fields, respectively) for each of the VME interfaces:

```
# netstat -i
```

The following example shows the output from a `netstat -i` command:

netstat -i							
Name	Mtu	Network	Address	Ipkts	Ierrs	Opkts	Oerrs
en0	1496	128.162.101	edge	253535	0	61027	0
fddi0	4352	128.162.84	edge-fddi	204070	0	24363	0
atm0	9180	128.162.83	edge_atm0	56	0	56	0
hi0*	65536	none	none	0	0	0	0
lo0	65535	127	localhost	200366	0	200366	0

- Remove one end of the cable to verify that the ping processes stop. This verifies that the packets are going out of the transmit port of the ATM card and being received through the receive port. If the ping process continues to run, verify that each step in this section was performed.
- Make the ATM network connection.
- At this point, you can perform other tests across the loopback connection. Some TCP tests that can be executed are `nettest(8)`, `ftp(1B)`, and `telnet(1B)`. Refer to the appropriate man pages for details.
- After performing these tests, disable the hardware loopback on each VME interface by executing the following command:

```
# /etc/ifconfig atm0 down
```

Repeat this command for each VME interface.

Configure Up TCP/IP for the VME Interfaces

To configure TCP/IP for the VME controllers, issue the `initif` command, as follows:

```
# /etc/initif atm0
```

The `initif(8)` command configures up the interface by performing an `ifconfig up` command and creates `atmarp` entries for each Permanent Virtual Circuit (PVC). Repeat this command for each VME interface.

Debugging a VME Problem

You can use the following commands as tools to debug a VME problem:

- `ifconfig(8)`
- `netstat(1B)`
- `atmarp(8)`
- `atmadmin(8)`

Removed Parts Disposition

Do not dispose of removed parts locally; return the removed parts to:

Cray Research, Inc.
1000 Halbleib Road
Chippewa Falls, WI 54729
Attention: Removed Equipment Management

Cruise Reporting

Report upgrades in CRUISE. Refer to *CS Reporting and Tracking Guidelines*, publication HOM-203-0, and *CRUISE User Guide*, publication HOM-248-0, for requirements and instructions.