

DSS-1 and DSS-2 Hardware Description

(Scalable I/O Architecture)

HMM-199-A

Silicon Graphics Proprietary

DSS-1/DSS-2 HW Description
HMM-199-A



SiliconGraphics
Computer Systems

Any shipment to a country outside of the United States requires a
letter of assurance from Silicon Graphics, Inc.

This document is the property of Silicon Graphics, Inc. The use of this document is subject to specific license rights extended by Silicon Graphics, Inc. to the owner or lessee of a Silicon Graphics, Inc. computer system or other licensed party according to the terms and conditions of the license and for no other purpose.

Silicon Graphics, Inc. Unpublished Proprietary Information — All Rights Reserved.

Autotasking, CF77, CRAY, CRAY-1, Cray Ada, CraySoft, CRAY Y-MP, CRInform, CRITurboKiva, HSX, LibSci, MPP Apprentice, SSD, SUPERCLUSTER, UNICOS, and X-MP EA are federally registered trademarks and Because no workstation is an island, CCI, CCMT, CF90, CFT, CFT2, CFT77, ConCurrent Maintenance Tools, COS, CRAY-2, Cray Animation Theater, CRAY APP, CRAY C90, CRAY C90D, Cray C++ Compiling System, CrayDoc, CRAY EL, CRAY J90, CRAY J90se, CrayLink, Cray NQS, Cray/REELlibrarian, CRAY S-MP, CRAY SSD-T90, CRAY T3D, CRAY T3E, CRAY T3E-900, CRAY T90, CrayTutor, CRAY X-MP, CRAY XMS, CSIM, CVT, Delivering the power . . ., DGauss, Docview, EMDS, GigaRing, HEXAR, IOS, ND Series Network Disk Array, Network Queuing Environment, Network Queuing Tools, OLNET, RQS, SEGLDR, SMARTE, SUPERLINK, System Maintenance and Remote Testing Environment, Trusted UNICOS, UNICOS MAX, and UNICOS/mk are trademarks of Cray Research, Inc., a wholly owned subsidiary of Silicon Graphics, Inc.

Silicon Graphics and the Silicon Graphics logo are registered trademarks and Origin and Origin2000 are trademarks of Silicon Graphics, Inc.

All other trademarks are the property of their respective owners.

Requests for copies of service publications should be directed to:

SILICON GRAPHICS, INC.
Customer and Professional Services - Logistics
1100 Lowater Road
P. O. Box 4000
Chippewa Falls, WI 54729-0078
USA

Comments about this publication should be directed to:

SILICON GRAPHICS, INC.
Customer and Professional Services
Service Publications and Training
890 Industrial Blvd.
P.O. Box 4000
Chippewa Falls, WI 54729-0078
USA

DSS-1 and DSS-2 Hardware Description

HMM-199-A
Scalable I/O Architecture
Last Modified: June 1998

Record of Revision	3
Product Overview	3
Functional Description	4
Physical Description	5
DSS-1/DSS-2 Enclosure	5
Enclosure Switches and Indicators	8
Disk Drive (DD-314, DD-318, and RD-318)	9
Power Supply	11
Controllers	13
MPN Controller (SCS-10)	13
CRAY J916 and CRAY J932 Controller (SI-3)	13
Equipment Specifications	14
Cabling Guidelines	15
Cable Configurations	15
Power Cable	17
DSS-1/DSS-2 I/O Cable	17
DSS-1/DSS-2 WACS Cable	18
Internal I/O Cable	19
Device Power Connector	19
Device Configuration Jumpers	20
Device ID Connector	21
Configuration Guidelines Reference	21
Flaw Management Reference	22
Installation Reference	22
Troubleshooting Reference	22
Field Replacement Procedures (FRPs) Reference	22

Figures

Figure 1.	DSS-1/DSS-2 Block Diagram	4
Figure 2.	DSS-1/DSS-2 Enclosure	5
Figure 3.	Disk Drive Locations	6
Figure 4.	DSS-1/DSS-2 Layout	7
Figure 5.	Enclosure LEDs and Drive ID Switch	8
Figure 6.	DSS-1/DSS-2 Disk Drive Front Panel	9
Figure 7.	DSS-1/DSS-2 Disk Drive (Removed from Canister)	10
Figure 8.	DSS-1/DSS-2 Power Supplies	11
Figure 9.	Voltage Select Switch	12
Figure 10.	DSS-1/DSS-2 Cable Configuration	16
Figure 11.	Internal I/O Cable	19
Figure 12.	Device Configuration Jumpers	20

Tables

Table 1.	DSS-1/DSS-2 Equipment Specifications	14
Table 2.	DSS-1/DSS-2 SCSI-2 Connector Pinout	17
Table 3.	WACS Connector Pinout	18
Table 4.	Disk Drive Power Connector Pinout	19
Table 5.	Drive ID Connector Pinout	21

Record of Revision

August 1996

Original printing.

June 1998: A

This revision changes the title of the document to match document contents; removes field replacement and installation procedures; adds references to *PC-10 Field Replacement Procedures* and *DSS-1/DSS-2 Hardware Upgrade Procedure*; and makes minor corrections.

Product Overview

The DSS-1 disk subsystem provides up to 75 Gbytes of data storage in a compact, rack-mounted peripheral enclosure. The enclosure contains up to eight 3.5-in. (8.9 cm) hard disk drives with two separate, common power supplies. Both the drives and the power supplies may be replaced during normal system operation, which provides a high degree of equipment resiliency.

The DSS-2 is functionally identical to the DSS-1. The only difference is that the connectors for the disk drives have a high insertion-cycle rating to enable media storage between accesses. Disk drive canisters also have high insertion-cycle connector ratings and the drives are designated RD-318 (equivalent to the DD-318). RD-318 drives are not interchangeable with DD-314 and DD-318 drives.

Because most information in this document applies equally to the DSS-1 and DSS-2 subsystems, they are hereafter referred to as DSS-1/DSS-2.

Functional Description

Figure 1 provides a functional block diagram of the DSS-1/DSS-2. An I/O cable connects each pair of DSS-1/DSS-2 disk drives to an I/O channel connector, in either a CRAY J90 series system or a multipurpose node (MPN-1) interface on a Cray Research GigaRing I/O channel. The interface protocol is the small computer system interface (SCSI) standard protocol.

Figure 1. DSS-1/DSS-2 Block Diagram

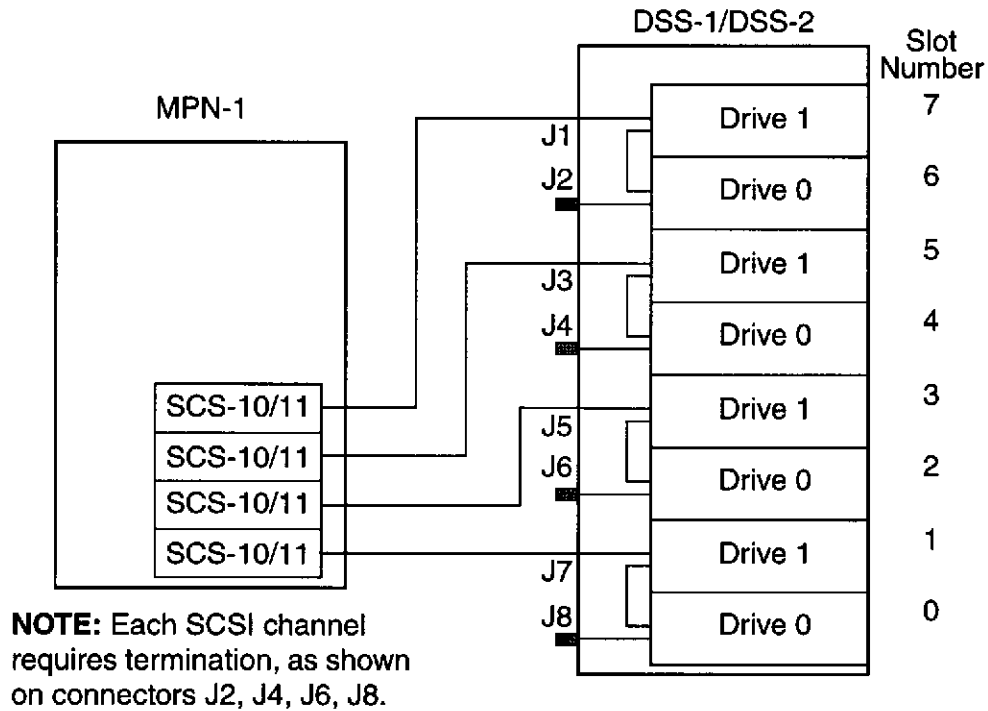

An SI-3 controller provides the interface from the DSS-1/DSS-2 to a CRAY J90 series system; an SCS-10 or SCS-11 controller in the MPN-1 provides the interface to a GigaRing channel.

As shown in Figure 1, drives may be daisy chained for greater channel capacity (although this limits individual channel accessibility). A terminator must be plugged onto the back panel of the DSS-1/DSS-2 enclosure to terminate each channel.

Physical Description

The DSS-1/DSS-2 is a 4-SU (7-in. [19.1 cm] high) enclosure that contains disk drives in removable canisters, redundant power supplies, and connectors for data cables and subsystem status cables.

DSS-1/DSS-2 Enclosure

The DSS-1/DSS-2 enclosure, shown in Figure 2, can contain a maximum of eight field replaceable SCSI disk drives. The enclosure also contains two power supplies, two cooling fans, internal SCSI cables, a warning and control system (WACS) interface printed circuit board (PCB), and a backplane PCB; all are field replaceable units (FRUs).

Figure 2. DSS-1/DSS-2 Enclosure

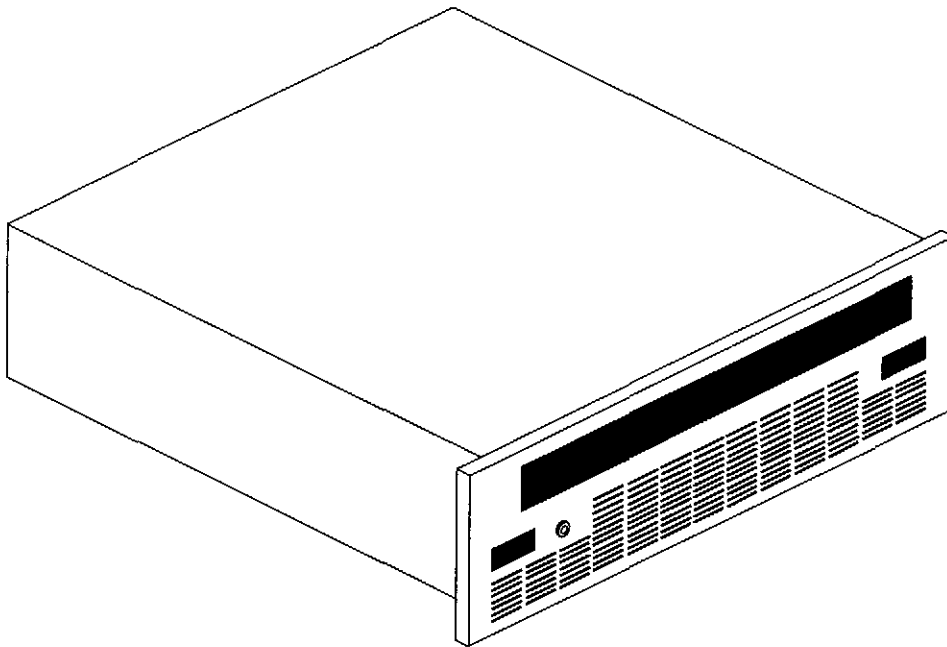

Figure 3 shows the DSS-1/DSS-2 front panel opened for access to the disk drives. The front panel has two latches that release (when unlocked) to allow the front panel to open and swing down. (Figure 8 shows the rear panel of the DSS-1/DSS-2.)

Figure 3. Disk Drive Locations

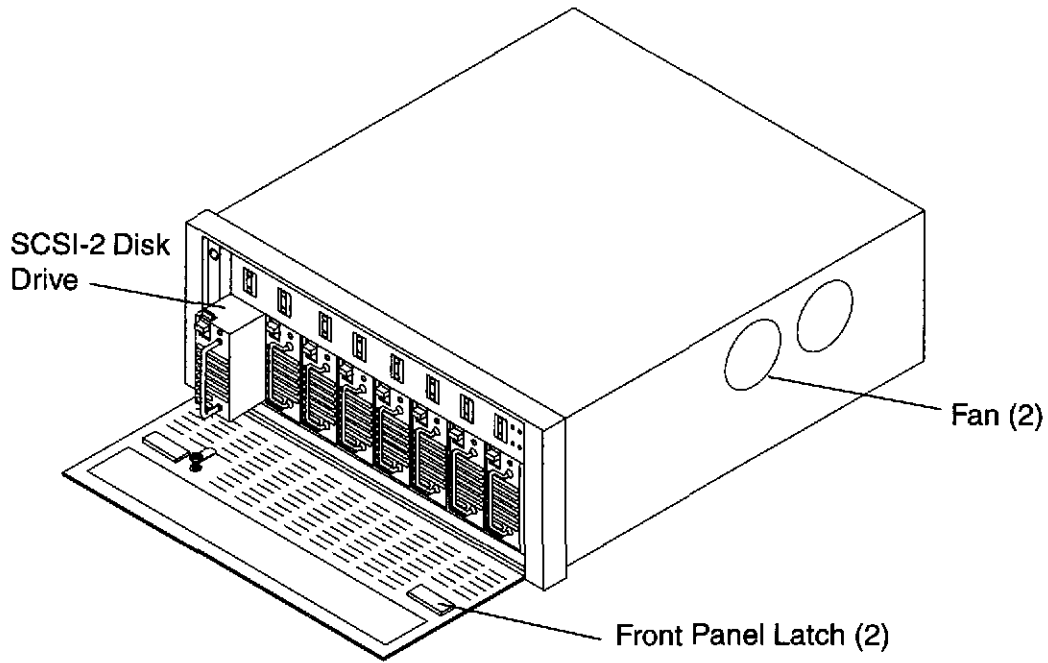
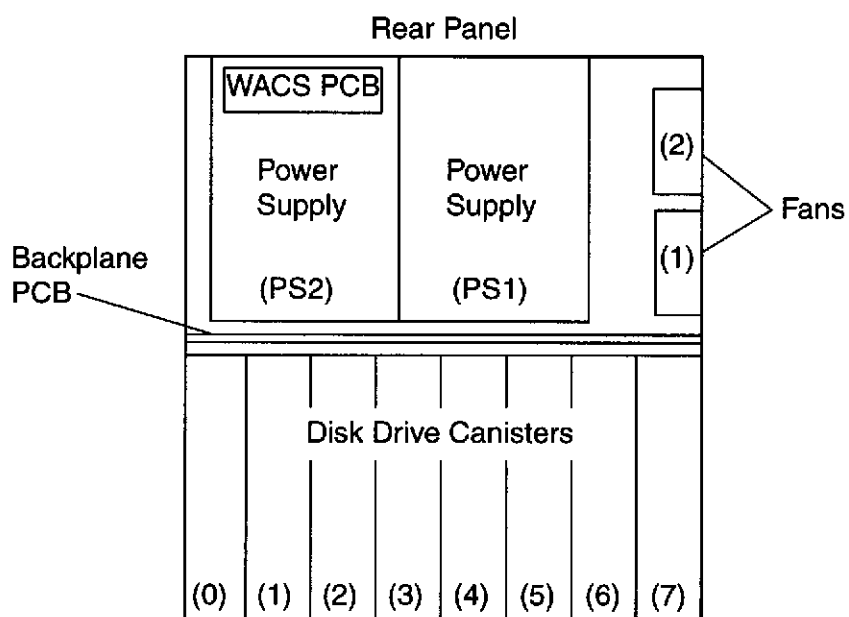

Figure 4 shows a top-down view of the contents of the DSS-1/DSS-2 enclosure with the top panel removed. The backplane PCB distributes DC power to all drives and to the two fans.

The WACS PCB in the DSS-1/DSS-2 accumulates power supply and fan status signals and reports them to the warning and control system (WACS). During power-up operation, the backplane sequences power to the drives to minimize power supply surge currents.

Figure 4. DSS-1/DSS-2 Layout



Enclosure Switches and Indicators

A device ID switch above each drive identifies the drive with a unique device number that ranges from 0 through 15 (IDs 7 and 15 are typically reserved for the SCS-10 controller). The switch displays the selected number, as shown in Figure 5.

Figure 5. Enclosure LEDs and Drive ID Switch

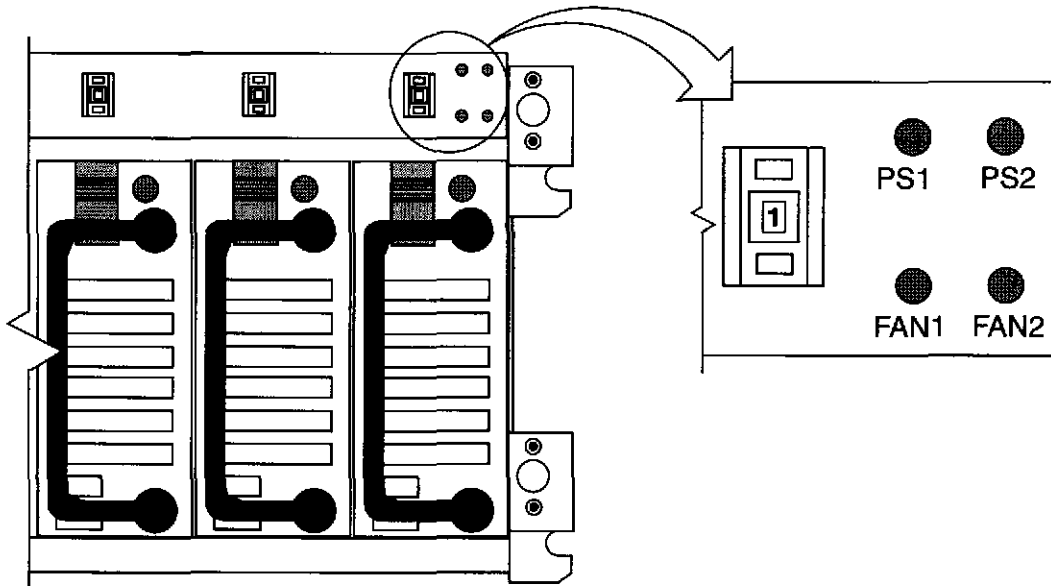

Two bicolor LEDs (PS1 and PS2), on the upper-right corner of the front panel, display the status of the two power supplies. Each indicator is green when its power supply is operating properly and red when a power supply fault occurs.

Two bicolor LEDs (FAN1 and FAN2), next to the power supply status indicators, display the status of the two cooling fans on the right side of the enclosure. Each indicator is green when its fan is operating properly and red when a fan fault occurs.

Disk Drive (DD-314, DD-318, and RD-318)

Each DSS-1/DSS-2 disk drive is mounted in a canister that plugs into the enclosure. Figure 6 shows the front panel of the disk drive in its canister. DSS-1 drives are available with either 4.5-Gbyte (the DD-314) or 9.4-Gbyte (the DD-318) capacities. DSS-2 drives are available with 9.4-Gbyte (the RD-318) capacity. (These drives are not part of the original DD-300 series of IPI disk drives.)

Figure 6. DSS-1/DSS-2 Disk Drive Front Panel

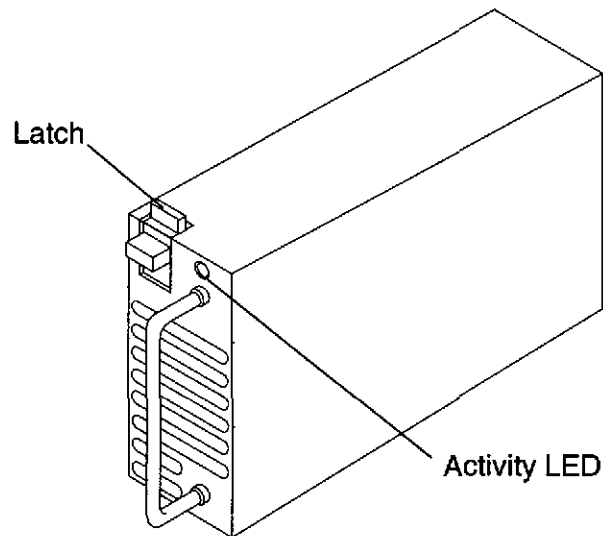
**CAUTION**

The disk drive is susceptible to mechanical damage if improperly handled. Observe the handling and packing precautions that are provided with the DSS-1/DSS-2 and replacement disk drives.

The front panel of the drive includes a swing-out, bail-style handle, a thumb-release latch, and a green activity status LED. The latch snaps into a slot in the enclosure and holds the drive securely. When installing the drive, make sure to push the drive firmly into the enclosure to seat the connector.

You must release the latch before you can pull the drive from the enclosure. During operation, the illuminated activity LED indicates that the drive is in the process of reading or writing data.

NOTE: You will lose data if you power down or unplug the drive while the activity LED is illuminated.

As shown in Figure 7, the drive has a DC power connector, a drive ID connector, and a SCSI I/O connector on the rear panel. Cables within the disk drive canister plug into these connectors and carry data, control, and power between the drive and a 96-pin connector on the rear panel of the drive canister. This arrangement enables automatic signal, power, and control connections during insertion and removal of the drive (in its canister) from the front of the enclosure. The “Cabling Guidelines” section, which begins on page 15, lists all connector pinouts.

Figure 7. DSS-1/DSS-2 Disk Drive (Removed from Canister)

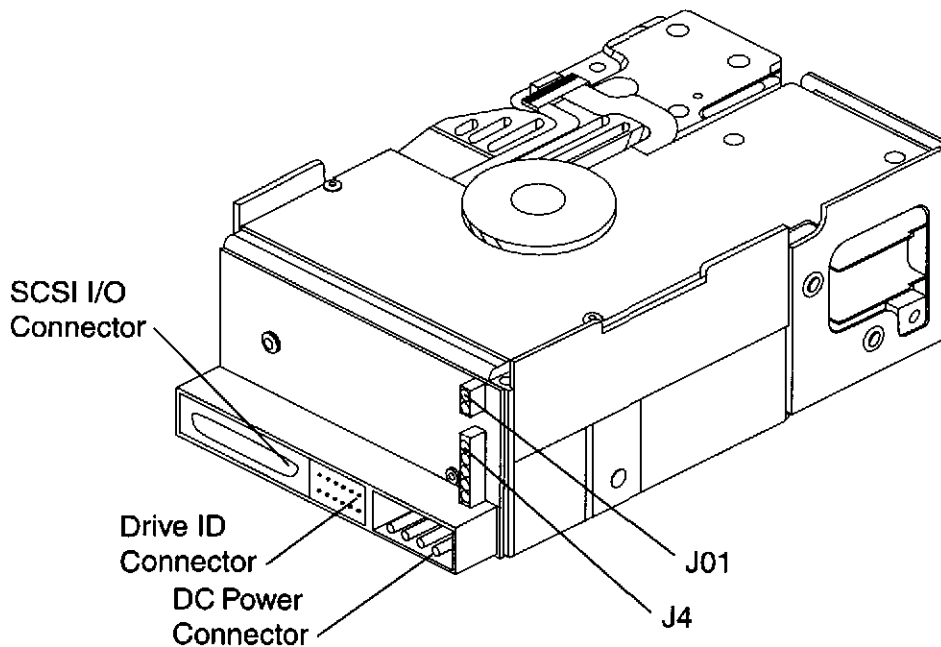

NOTE: The lines point to pin number one on each connector.

Air drawn in through the enclosure front panel cools the drive. Power supply fans and enclosure fans create this air movement.

NOTE: Proper drive cooling requires adequate airflow. Never operate the DSS-1/DSS-2 without the enclosure top panel in place. Always cover any open drive slots in the enclosure front panel to avoid loss of airflow through operating disk drive canisters. Never block airflow through the front panels of either the enclosure or the disk drives.

Power Supply

The two DSS-1/DSS-2 power supplies, shown in Figure 8, are connected in parallel; each is capable of providing power for all drives within the enclosure. This redundant (N+1) configuration enables the disk drive subsystem to continue operating if one of its two power supplies fails and needs to be replaced.

Figure 8. DSS-1/DSS-2 Power Supplies

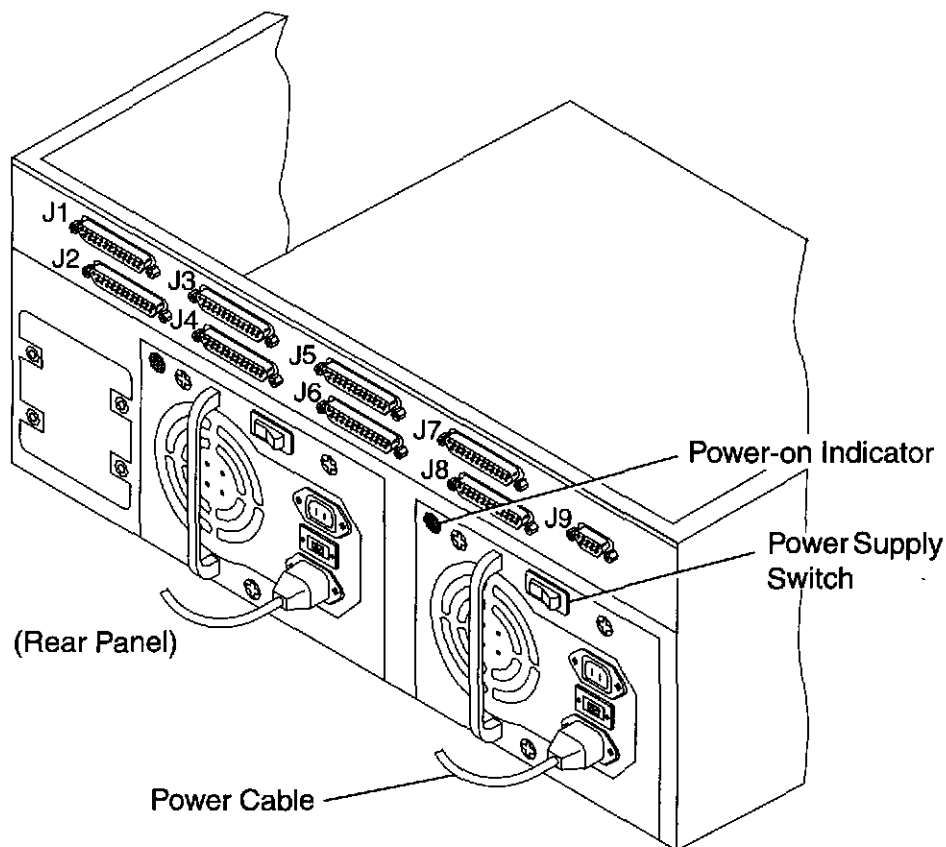

Each power supply has an ON/OFF power switch that is accessible from the rear of the enclosure. A green power-on indicator, which is part of the DSS-1/DSS-2 enclosure, indicates a functioning power supply.

Each power supply may contain a voltage select switch (labeled 115/230) that is located just above the power cable connector. Make sure this switch is set for the proper line voltage (230) before you turn on the power supply.

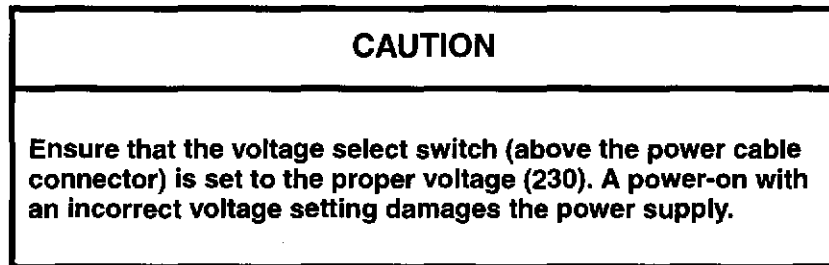
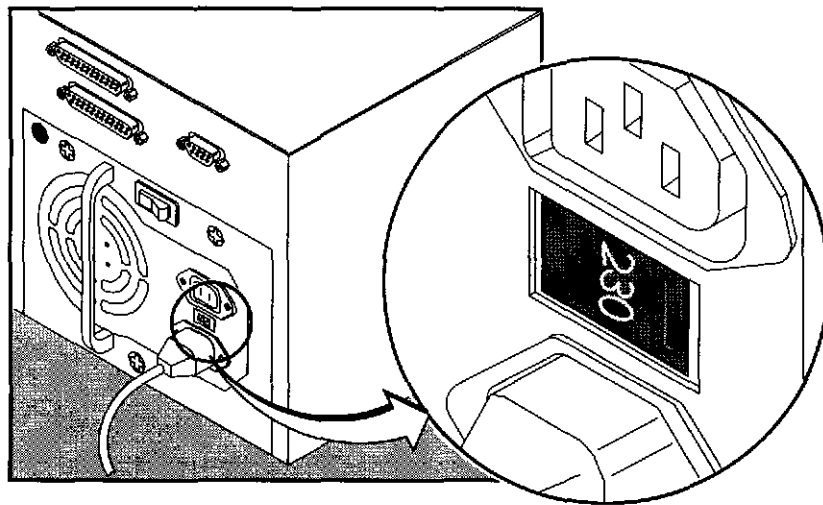

Figure 9. Voltage Select Switch



Each power supply is *hot swappable*, which means that it may be turned off, unplugged, and replaced without affecting normal system operation. The only requirements for this feature are that the remaining power supply is functioning properly and that the replacement sequence does not result in the rear panel being open for more than a few seconds because of the constant airflow that is required for adequate drive cooling.

The power cable to the power supplies is a Y-configuration, which enables either power supply to operate in the absence of a power connection to the other. The upper, power-out daisy chain connector should not be used in the DSS-1/DSS-2.

Controllers

The DSS-1/DSS-2 may be interfaced to either a computer system that uses a GigaRing channel for internal system communication or to a CRAY J90 series system. Each type of interface requires a different peripheral controller.

MPN Controller (SCS-10)

The SCS-10 or SCS-11 peripheral controller that interfaces the DSS-1/DSS-2 to the GigaRing channel is an SBus-based controller in the MPN. The SCS-10 and SCS-11 plug into one of eight SBus slot connectors on the SBus peripheral interface (SPI) printed circuit board in the MPN. The SCS-10 provides a standard SCSI-2 protocol for transfer of 16-bit differential data to the disk drives; the SCS-11 provides a standard SCSI-3 protocol for transfer of 16-bit differential data to the disk drives. Each single-channel SCS-10 or SCS-11 provides an interface connection for up to 15 SCSI devices.

CRAY J916 and CRAY J932 Controller (SI-3)

The SI-3 peripheral controller interfaces the DSS-1/DSS-2 to a CRAY J90 series system. The SI-3 is VME-based controller and resides in the VME chassis. Each SI-3 supports two SCSI-2 channels. Each of these channels can provide an interface connection for a maximum of 15 SCSI-2 devices. However, for optimum performance, each channel connects to only two drives in the DSS-1/DSS-2.

Equipment Specifications

Table 1 contains a list of physical, functional, and performance specifications for the disk subsystem and for each drive in the subsystem.

Table 1. DSS-1/DSS-2 Equipment Specifications

Parameter	Value	
DSS-1/DSS-2 specifications (installed in a PC-10 cabinet):		
Height	7.0 in. (19.1 cm) (4 SU)	
Width	22.25 in. (56.5 cm)	
Depth	23.0 in. (58.4 cm)	
Weight	90 lb (40.9 kg) maximum	
Power required	115 Vac, 4.0 Amp 230 Vac, 2.0 Amp 47 – 63 Hz	
Cooling required	1.1 kBtu/hr maximum	
Drive specifications (installed in a DSS-1/DSS-2 enclosure):		
	DD-314 Disk Drive	DD-318 Disk Drive RD-318 Disk Drive
Capacity (formatted in 4096-byte sections)	4509 Mbytes	9439 Mbytes
Logical block size (sector size)	4096 bytes	4096 bytes
Logical blocks	1,048,000	1,048,000
Read/write heads	20	20
Data cylinders	3711	5273
Tracks/surface	3711	5273
Bytes/surface	215 Mbytes	470 Mbytes
Sectors/track	12 - 18	16 - 27
Bytes/track	49,350 (minimum) 74,900 (maximum) 29 zones	78,540 (minimum) 122,173 (maximum) 7 zones
Rotational speed	7200 rpm	7200 rpm
Rotational latency	4.17 ms (average)	4.17 ms (average)
Seek time (average)	8 ms (read) 9 ms (write)	8.2 ms (read) 9.7 ms (write)
Track-to-track seek time	1.6 ms (read) 1.9 ms (write)	0.8 ms (read) 1.2 ms (write)
Full-stroke seek time	20.0 ms	20.2 ms
Sustained transfer rate	4.8 - 7.4 MBytes/s	8 - 12 MBytes/s
Data buffer (cache-usable)	954 Kbytes	1948 Kbytes

Cabling Guidelines

Cable Configurations

The DSS-1/DSS-2 is configured internally by the backplane as 4 pairs of disk drive slots. The pairs are J1/J2, J3/J4, J5/J6, and J7/J8. Each of the 8 connectors is associated with 1 of the 8 drive slots. Each drive pair can be connected to a SCSI-10/SCSI-11 and/or to another drive pair within the subrack. Refer to Figure 10 for examples of configurations within a subrack. The following configurations are possible:

- 4 individual channels of 2 drives each (example 1)
- 2 individual channels of 4 drives each (example 2)
- 2 individual channels: 1 channel of 6 drives and 1 channel of 2 drives (not shown)
- 1 channel of 8 drives (example 3)
- 2 individual channels: 1 channel of 2 drives and 1 channel with the maximum configuration of 14 drives (example 4)

Typically connectors J1, J3, J5, and J7 are the input for the drive pair and connectors J2, J4, J6, and J8 terminate the SCSI bus or daisy chain to the next drive pair. Example 4 shows two DSSs chained together when more than 8 drives are required on a SCSI bus.

Figure 10. DSS-1/DSS-2 Cable Configuration

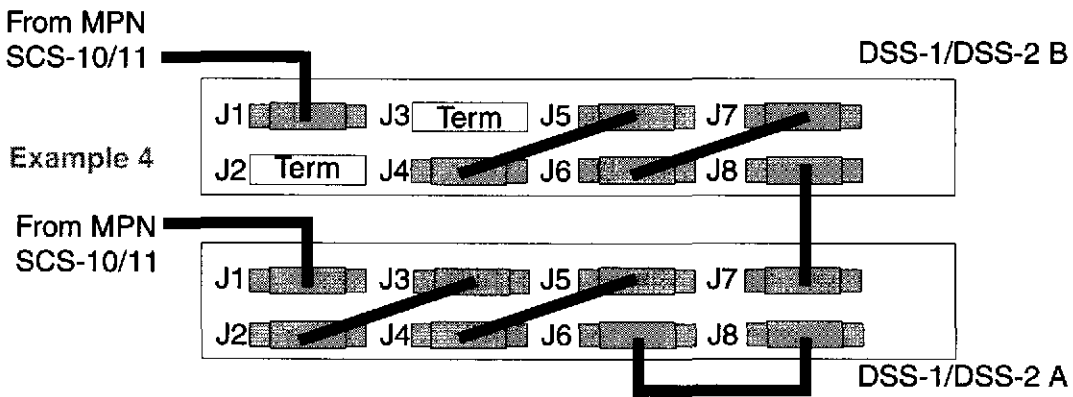
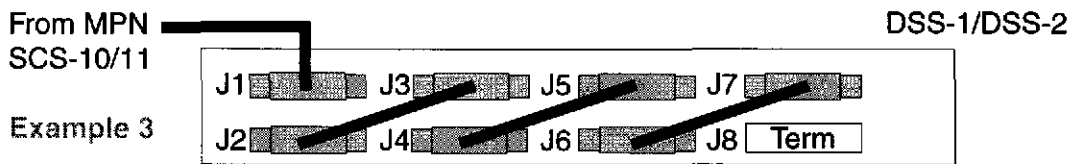
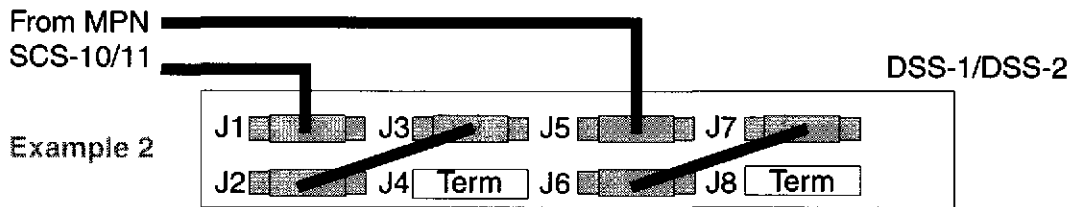
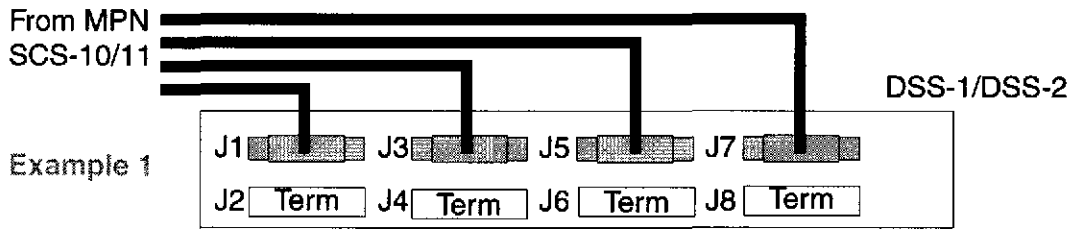

Power Cable

A Y-cable connects both power supplies to one power plug, which plugs into one of the power outlets of the PC-10 power distribution strip.

NOTE: Do not use the second, daisy-chain power connector on either power supply to provide power to any other equipment. Doing so will defeat the hot-swappable feature of the power supplies.

DSS-1/DSS-2 I/O Cable

The I/O cable between the computer system and the DSS-1/DSS-2 rear panel I/O connector has a micro-D style, 68-pin male connector. Table 2 describes the signals that the connector carries.

Table 2. DSS-1/DSS-2 SCSI-2 Connector Pinout

Pin No.	Signal Name	Pin No.	Signal Name
1	+DB12	35	-DB12
2	+DB13	36	-DB13
3	+DB14	37	-DB14
4	+DB15	38	-DB15
5	+DBP1	39	-DBP1
6	Ground	40	Ground
7	+DB0	41	-DB0
8	+DB1	42	-DB1
9	+DB2	43	-DB2
10	+DB3	44	-DB3
11	+DB4	45	-DB4
12	+DB5	46	-DB5
13	+DB6	47	-DB6
14	+DB7	48	-DB7
15	+DBP	49	-DBP
16	DIFFSENS	50	Ground
17	TERMPWR	51	TERMPWR
18	TERMPWR	52	TERMPWR
19	(Reserved)	53	(Reserved)
20	+ATN	54	-ATN
21	Ground	55	Ground
22	+BSY	56	-BSY
23	+ACK	57	-ACK

Table 2. DSS-1/DSS-2 SCSI-2 Connector Pinout (continued)

Pin No.	Signal Name	Pin No.	Signal Name
24	+RST	58	-RST
25	+MSG	59	-MSG
26	+SEL	60	-SEL
27	+C/D	61	-C/D
28	+REQ	62	-REQ
29	+I/O	63	-I/O
30	Ground	64	Ground
31	+DB8	65	-DB8
32	+DB9	66	-DB9
33	+DB10	67	-DB10
34	+DB11	68	-DB11

DSS-1/DSS-2 WACS Cable

The status cable between the DSS-1/DSS-2 rear panel and the WACS carries the signals listed in Table 3.

Table 3. WACS Connector Pinout

Pin No.	Signal Name	Pin No.	Signal Name
1	PS1 Good	6	Fan Return (Ground)
2	PS1 Return (Ground)	7	Install
3	PS2 Good	8	Install Return (Ground)
4	PS2 Return (Ground)	9	+5 Vdc (Power from WACS)
5	Fan Fault		

Internal I/O Cable

Each of the disk drives has an I/O cable as shown in Figure 11 that carries the signals inside the DSS-1/DSS-2 from the backplane PCB to the rear panel. The pinout matches the pinout listed in Table 2.

Figure 11. Internal I/O Cable

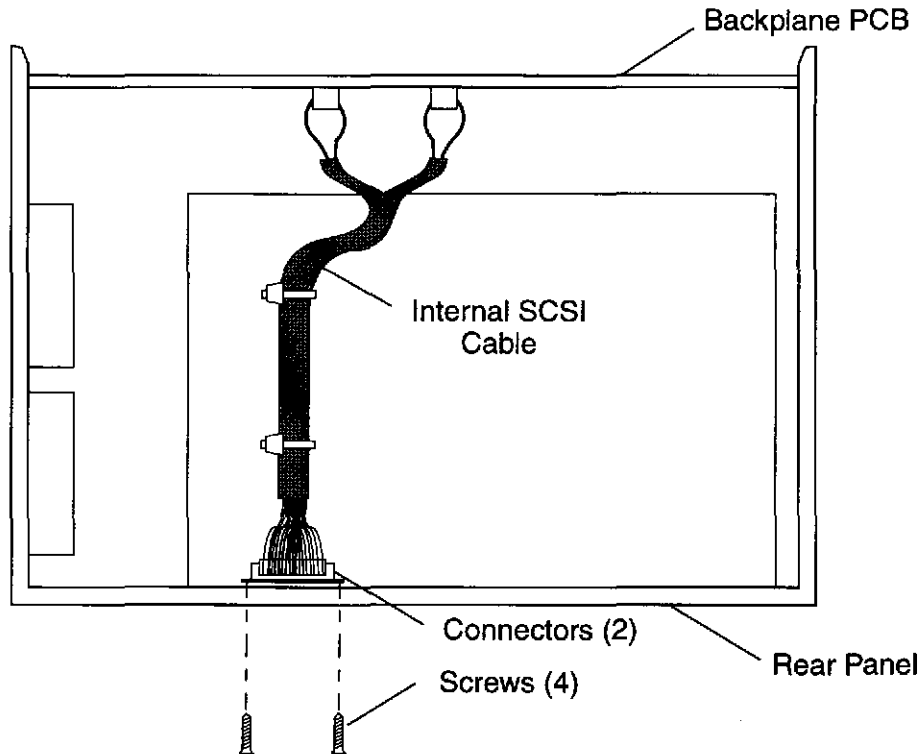

Device Power Connector

The 4-pin power connector on the rear panel of each disk drive, inside the drive canister, provides connections for the voltages listed in Table 4.

Table 4. Disk Drive Power Connector Pinout

Pin No.	Voltage
1	+12 Vdc
2	+12 Vdc return
3	+5 Vdc return
4	+5 Vdc

Device Configuration Jumpers

Two headers on the rear panel of each disk drive inside the drive canister (labeled J01 and J4 in Figure 7) hold jumpers that establish drive operational parameters. Figure 12 shows the position of all jumpers that are installed in J01 and J4. The jumper at position 2 (delay motor start) of J4 is in parallel with a similar connection on the backplane, and is therefore redundant. The jumper at position 3 (enable motor start) of J4 depends on customer requirements and is installed by system checkout engineers before hardware shipment to the site.

Figure 12. Device Configuration Jumpers

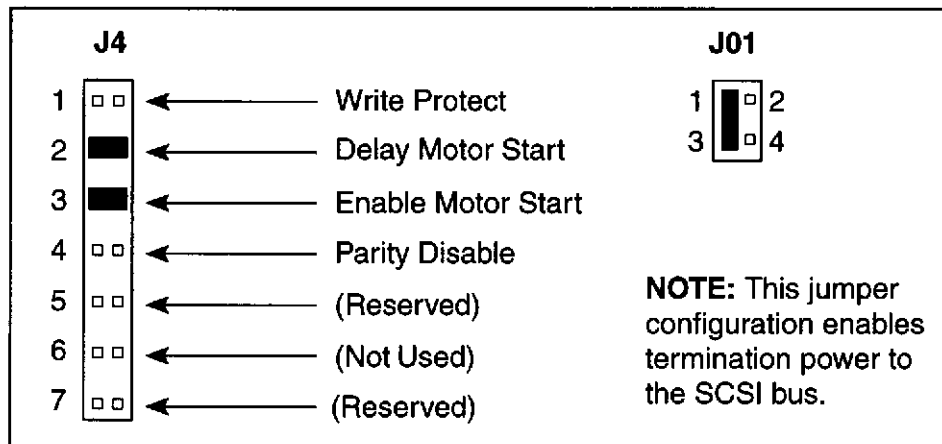
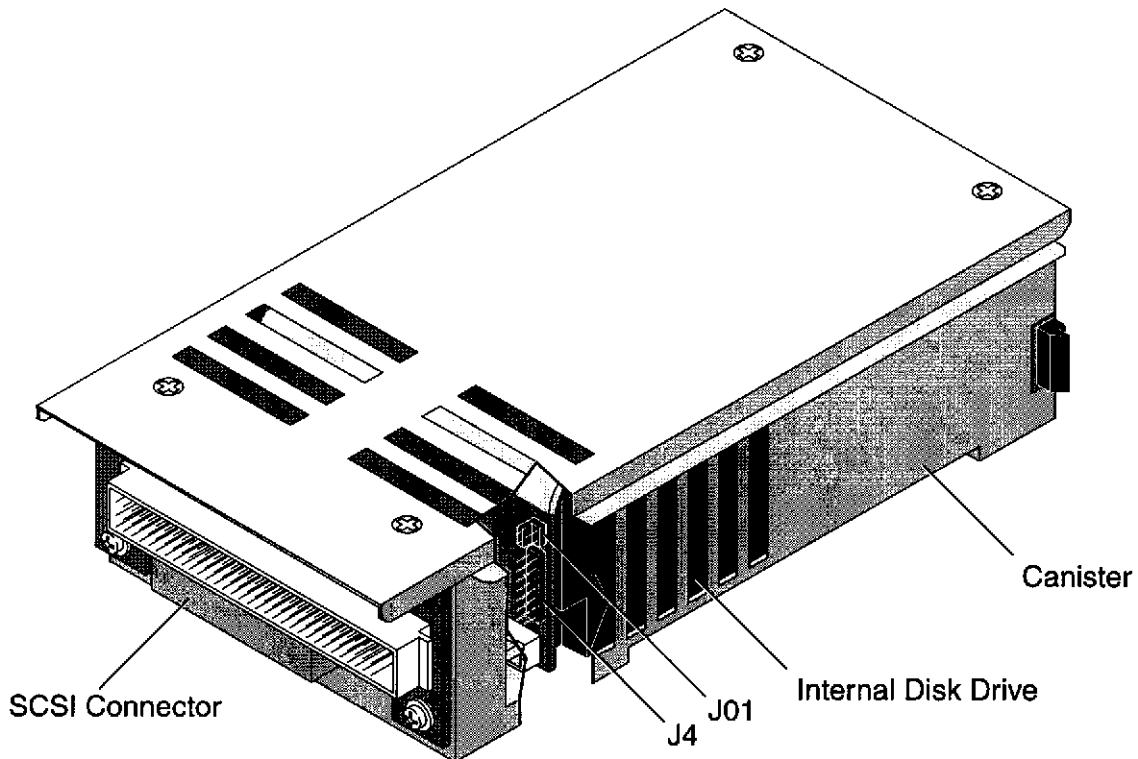

Device ID Connector

The front-panel device ID switch above each drive connects to the drive ID connector, shown in Figure 7, on the rear panel of the drive. Table 5 lists the continuity (1) or open (0) condition that exists in the ID switch at each of the six connector positions.

Table 5. Drive ID Connector Pinout

Device ID No.	Continuity (6, 5, 4, 3, 2, 1)
0	0 0 0 0 0 0
1	0 0 0 0 0 1
2	0 0 0 0 1 0
3	0 0 0 0 1 1
4	0 0 0 1 0 0
5	0 0 0 1 0 1
6	0 0 0 1 1 0
7	0 0 0 1 1 1
8	0 0 1 0 0 0
9	0 0 1 0 0 1
10	0 0 1 0 1 0
11	0 0 1 0 1 1
12	0 0 1 1 0 0
13	0 0 1 1 0 1
14	0 0 1 1 1 0
15	0 0 1 1 1 1

Configuration Guidelines Reference

All drives operate independently. Consult the *Scalable I/O Product Configuration Guide*, EMG-1068, for further information about configurations.

Flaw Management Reference

Each disk drive contains its own SCSI controller, which automatically performs flaw management for errors that have recoverable error-correction codes (ECCs). Errors that have unrecoverable ECCs can be reallocated using the `xdfs` command. Refer to the *Concurrent Diagnostic Tools Reference—Command-line Version* (CRI publication HDM-194-0) for details on using `xdfs` to reallocate disk space.

Installation Reference

Refer to *DSS-1/DSS-2 Hardware Upgrade Procedure*, CRI publication HMU-384-0, for procedures for installing the DSS-1 and DSS-2.

Troubleshooting Reference

Diagnostic Descriptions

Refer to the *Boot Diagnostics and Tests* document, CRI publication HDM-301-0, for descriptions of tests that you can use to boot SIO single-purpose nodes and the multipurpose node.

Troubleshooting Procedures

Refer to *SIO Troubleshooting Guide*, CRI publication HMM-204-A, which contains troubleshooting procedures for diagnosing faults in the MPN and in the SCSI disk drives that connect to it.

Refer to the *CRAY J90 Series System Troubleshooting* document, CRI publication HMM-114-B, for troubleshooting information about diagnosing faults in the SI-3 interface and in the SCSI disk drives that connect to it.

Field Replacement Procedures (FRPs) Reference

Refer to *PC-10 Field Replacement Procedures*, CRI publication HMM-236-F, for replacement procedures for the DSS-1 and the DSS-2.

Reader Comment Form

Title: DSS-1 and DSS-2 Hardware Description

Number: HMM-199-A

Your feedback on this publication will help us provide better documentation in the future. Please take a moment to answer the few questions below.

For what purpose did you primarily use this document?

Troubleshooting

Tutorial or introduction

Reference information

Classroom use

Other - please explain

Using a scale from 1 (poor) to 10 (excellent), please rate this document on the following criteria and explain your ratings:

Accuracy _____

Organization _____

Readability _____

Physical qualities (binding, printing, page layout) _____

Amount of diagrams and photos _____

Quality of diagrams and photos _____

Completeness (Check one and explain your answer)

Too much information Too little information Correct amount

You may write additional comments in the space below. Mail your comments to the address below, fax them to us at +1 715 726 4353, or e-mail them to us at spt@cray.com. When possible, please give specific page and paragraph references. We will respond to your comments in writing within 48 hours.

NAME _____

JOB TITLE _____

E-MAIL ADDRESS _____

SITE/LOCATION _____

TELEPHONE _____

DATE _____

[or attach your business card]



SiliconGraphics

Attn: Service Publications and Training
890 Industrial Boulevard
P.O. Box 4000
Chippewa Falls, WI 54729-0078
USA